

## Operating manual

### **ASC 150** Cummins

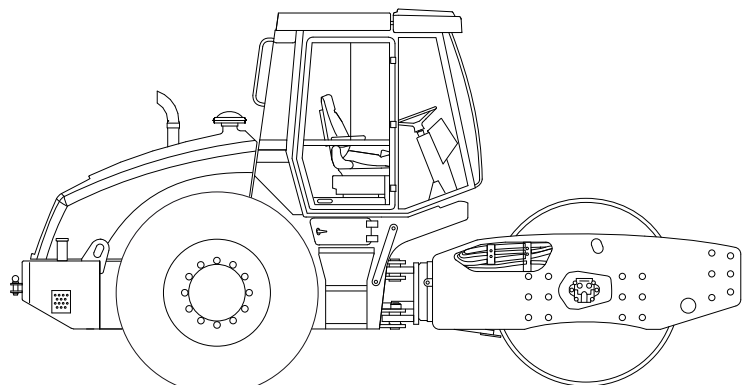



**ASC 150**  
**Single drum roller**  
Cummins Tier 3

**Operating manual**

Edition 02/2011 EN  
From Serial No. 2883001  
Translation of Original Operating Manual



# ES Prohlášení o shodě

(Původní ES prohlášení o shodě / Original EC Declaration of conformity / Ursprüngliche EG-Konformitätserklärung)

## EC Declaration of conformity / EG-Konformitätserklärung

(Překlad původního ES prohlášení o shodě / Translation original EC Declaration of conformity / Übersetzung der ursprünglichen EG-Konformitätserklärung)

Originální ES prohlášení o shodě je dodané s dokumenty během expedice stroje. / The original EC Declaration of Conformity is supplied with documents during expedition of machine. / Das Original der EG-Konformitätserklärung wird mit den Unterlagen während des Versands der Maschine mitgeliefert.

<b>Výrobce / Manufacturer / Hersteller:</b>	Ammann Czech Republic a.s.
<b>Adresa / Address / Adresse:</b>	Náchodská 145, CZ-549 01 Nové Město nad Metují, Czech Republic
<b>IČ / Identification Number / Ident.-Nr:</b>	000 08 753
<b>Jméno a adresa osoby pověřené sestavením technické dokumentace podle 2006/42/ES a jméno a adresa osoby, která uchovává technickou dokumentaci podle 2000/14/ES / Name and address of the person authorised to compile the technical file according to 2006/42/EC and name and address of the person, who keeps the technical documentation according to 2000/14/EC / Name und Adresse der mit der Zusammenstellung der technischen Dokumentation beauftragten Person gemäß 2006/42/EG und Name und Adresse der mit der Aufbewahrung der technischen Dokumentation beauftragten Person gemäß 2000/14/EG:</b>	Ing. Radek Ostrý Ammann Czech Republic a.s. Náchodská 145, CZ-549 01 Nové Město nad Metují, Czech Republic
<b>Popis strojního zařízení / Description of the machinery / Beschreibung der Maschineneinrichtung:</b>	
<b>Označení / Designation / Bezeichnung:</b>	Tahačový válec / Single drum roller / Walzenzug
<b>Typ / Type / Typ:</b>	ASC 150
<b>Verze / Version / Version:</b>	
<b>Výrobní číslo / Serial number / Maschinenummer:</b>	
<b>Motor / Engine / Motor:</b>	Cummins QSB 4.5-C160, vznětový, jmenovitý výkon (ISO 3046-1): 119,0 kW, jmenovité otáčky: 2200 min <sup>-1</sup> . / Cummins QSB 4.5-C160, Diesel, nominal power (ISO 3046-1): 119,0 kW, rated speed: 2200 RPM. / Cummins QSB 4.5-C160, Dieselmotor, Nennleistung (ISO 3046-1): 119,0 kW, Nenndrehzahl: 2200 min <sup>-1</sup> .
<b>Prohlašujeme, že strojní zařízení splňuje všechna příslušná ustanovení uvedených směrnic / We declare, that the machinery fulfils all the relevant provisions mentioned Directives / Wir erklären, dass die Maschineneinrichtung sämtliche entsprechenden Bestimmungen aufgeführter Richtlinien erfüllt:</b>	Strojní zařízení – směrnice 2006/42/ES / Machinery Directive 2006/42/EC / Maschineneinrichtung – Richtlinie 2006/42/EG Elektromagnetická kompatibilita – směrnice 2004/108/ES / Electromagnetic Compatibility Directive 2004/108/EC / Elektromagnetische Kompatibilität – Richtlinie 2004/108/EG Emise hluku – směrnice 2000/14/ES / Noise Emission Directive 2000/14/EC / Lärmemissionen – Richtlinie 2000/14/EG
<b>Harmonizované technické normy a technické normy použité k posouzení shody / The harmonized technical standards and the technical standards applied to the conformity assessment / Harmonisierte technische Normen und für die Beurteilung der Konformität verwendete Normen:</b>	ČSN EN ISO 12100-2, ČSN EN 500-1+A1, ČSN EN 500-4+A1, ČSN EN 982+A1, ČSN EN 13309:2001
<b>Osoby zúčastněné na posouzení shody / Bodies engaged in the conformity assessment / An der Konformitätsbeurteilung beteiligte Personen:</b>	Notifikovaná osoba č. 1016 / Notified Body No.: 1016 / Notifizierte Stelle Nr.: 1016 Státní zkušebna zemědělských, lesnických a potravinářských strojů, a. s., Třanovského 622/11, 163 04 Praha 6–Řepy, ČR. / The Government Testing Laboratory of Agricultural, Food Industry and Forestry Machines, Joint-stock company, Třanovského 622/11, 163 04 Praha 6–Řepy, Czech Republic / Staatliche Prüfanstalt für Land-, Forst- und Lebensmittelmaschinen, AG Třanovského 622/11, 163 04 Praha 6–Řepy, Tschechische Republik.
<b>Použitý postup posouzení shody / To the conformity assessment applied procedure / Verwendetes Vorgehen der Konformitätsbeurteilung:</b>	Na základě směrnice 2000/14/ES příloha VI / Pursuant to the Noise Emission Directive 2000/14/EC, Annex VI / Aufgrund der Richtlinie 2000/14/EG, Anlage VI
<b>Naměřená hladina akustického výkonu / Measured sound power level / Gemessener Schallleistungspegel:</b>	L <sub>WA</sub> = 106 dB
<b>Garantovaná hladina akustického výkonu / Guaranteed sound power level / Garantierter Schallleistungspegel:</b>	L <sub>WA</sub> = 107 dB

**Místo a datum vydání / Place and date of issue / Ort und Datum der Ausgabe:**

Nové Město nad Metují,

**Osoba zmocněná k podpisu za výrobce / Signed by the person entitled to deal in the name of manufacturer / Zeichnungsberechtigter für den Hersteller:**

**Jméno / Name / Name:**

Ing. Jiří Macháček

**Funkce / Grade / Stelle:**

Quality Control Manager

**Podpis / Signature / Unterschrift:**



Congratulations on your purchase of an AMMANN road roller. This modern compaction device is characterised by simple operation and maintenance and is the product of many years of AMMANN experience in the field of road roller engineering. In order to avoid faults due to improper operation and maintenance we request that you read this operating manual with great care and keep it for later reference.

With kind regards,



Ammann Czech Republic a.s. | Náchodská 145 | CZ-549 01 Nové Město nad Metují

☎ + 420 491 476 111 | Fax + 420 491 470 215 | info@ammann-group.com | www.ammann-group.com

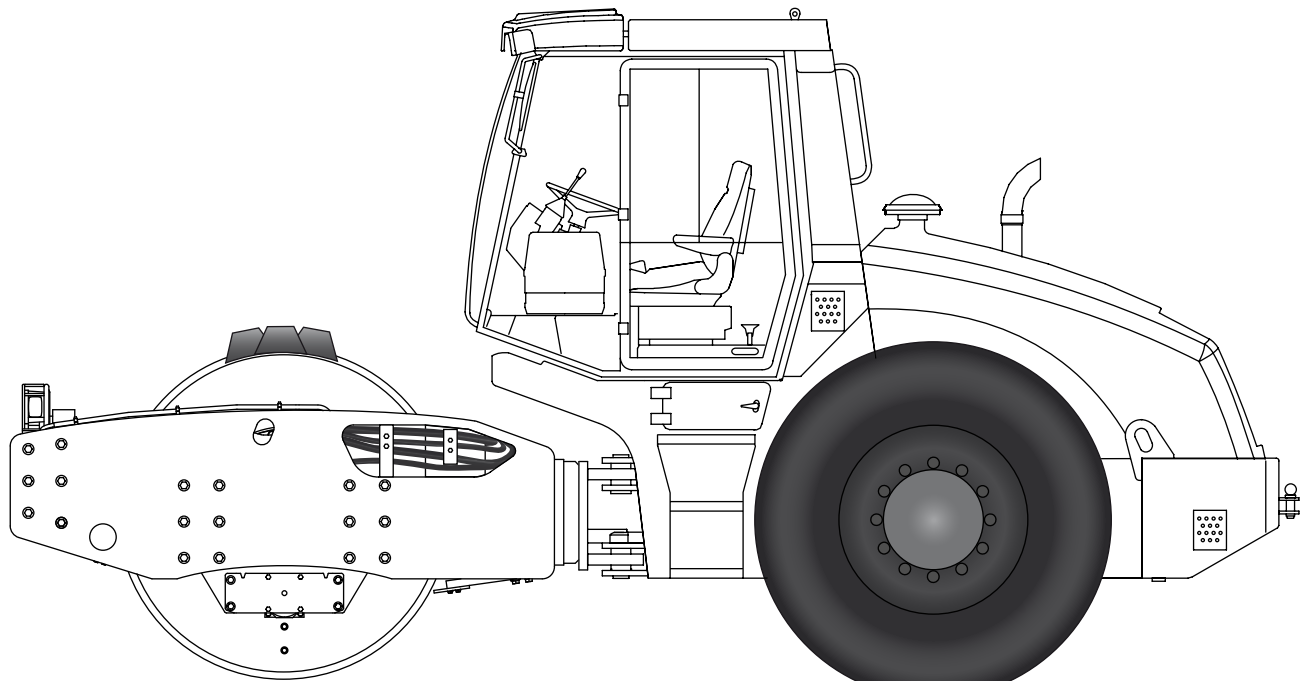

277016

**This manual consists of:**

I. Specification manual

II. Operating instructions

III. Maintenance manual

The following explanations serve to familiarise the machinist (operator) with the roller and to support him during handling and maintenance. It is therefore absolutely necessary to provide the operator with these instructions and to ensure that he reads them carefully before using the road roller. This aids training comprehension during the first use of the road roller.

Subsequent faults due to improper operating are avoided.

Adherence to maintenance instructions increases the reliability and lifetime of the machinery. It reduces repair costs and down time.

AMMANN accepts no liability for continued safe functioning of the road roller if it is incorrectly operated and / or operating modes are employed which represent improper use.

Spare parts must meet AMMANN technical specifications. These requirements are fulfilled if only original AMMANN spare parts are used.

**These instructions must always be kept available on the equipment.**

## **Preface**

Information, specifications, and recommended operation and maintenance instructions contained in this publication are basic and final information at the time of the printing of this publication. Printer's errors, technical modifications, and modifications of figures are reserved. All dimensions and weights are approximate and, therefore, not binding.

Ammann Czech Republic a.s. reserves the right to perform modifications without obligation to inform the machine user. If you identify any differences between the machine operated by you and the information contained in this publication, contact your local dealer.

Reproduction or copying of any kind is prohibited without the written permission of Ammann Czech Republic a.s.

### SYMBOLS OF THE SAFETY NOTICES:



The notice warns of a serious risk of personal injury or other personal hazards.



The notice warns of possible damages to the machine or its parts.



The notice warns of the necessity of environmental protection.

### ! NOTICE !

As used in this operating manual, the terms „right“, „left“, „front“ and „rear“ indicate the sides of the machine moving forward.

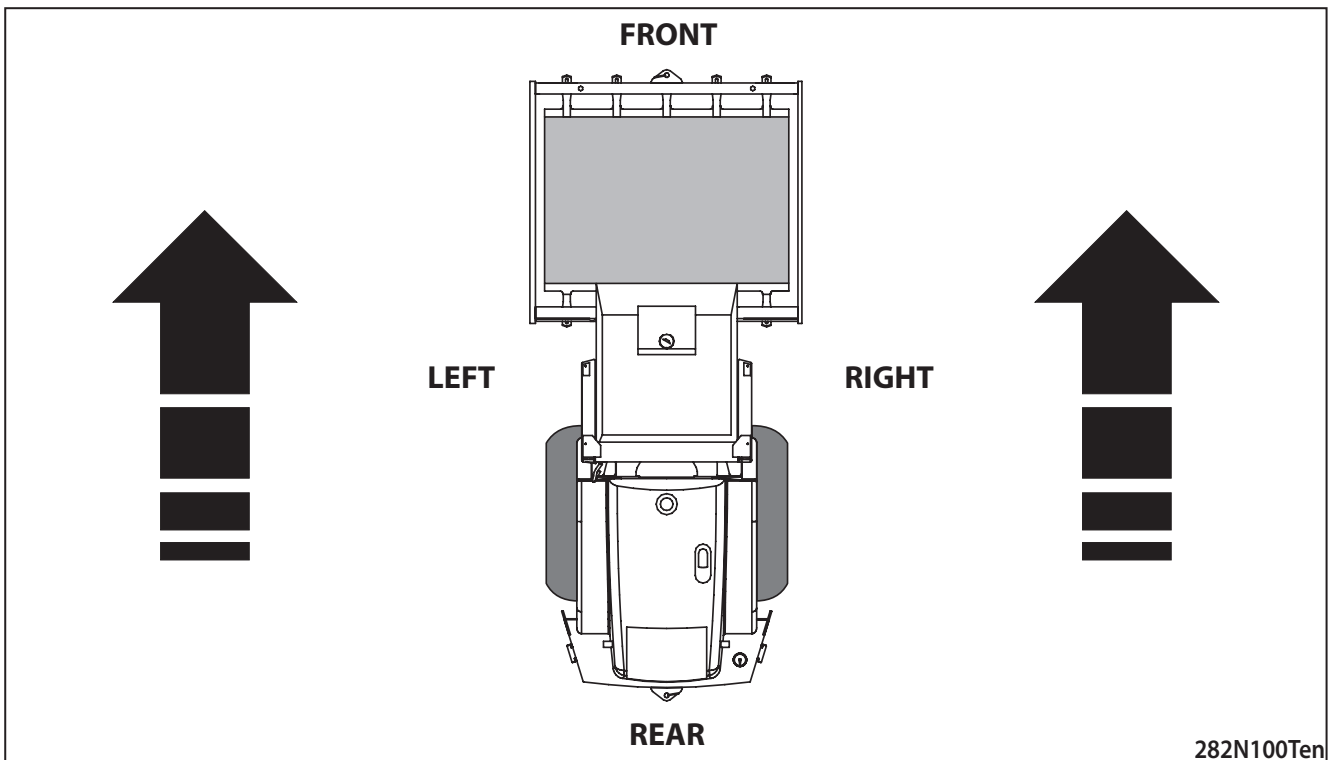

282N100Ten

# Content

---

<b>Content</b> .....	<b>4</b>
<b>1. SPECIFICATION MANUAL</b> .....	<b>9</b>
<b>1.1. Basic Data</b> .....	<b>10</b>
<b>1.2. Dimension Chart</b> .....	<b>12</b>
<b>1.3. Technical Data</b> .....	<b>14</b>
1.3.1. Weight.....	14
1.3.2. Riding characteristics .....	15
1.3.3. Steering .....	15
1.3.4. Motor.....	16
1.3.5. Axle .....	16
1.3.6. Brakes.....	16
1.3.7. Vibration.....	16
1.3.8. Fluid capacities .....	17
1.3.9. Electrical Installation.....	17
1.3.10. Noise and vibration emissions.....	17
1.3.11. Optional equipment.....	18

<b>2. OPERATION MANUAL .....</b>	<b>21</b>
<b>2.1. Major Safety Precautions.....</b>	<b>23</b>
2.1.1. Safety Measures during Machine Operation .....	23
2.1.1.1. Compaction Work Commencement .....	23
2.1.1.2. Work Safety Secured by User.....	23
2.1.1.3. Ensurance of safety measures by the owner .....	24
2.1.1.4. ROPS.....	24
2.1.2. Requirements on Driver's Qualification .....	25
2.1.3. Driver's Liabilities .....	26
2.1.4. Banned Operations .....	27
2.1.5. Safety inscriptions and signs used on the Machine .....	28
2.1.6. Hand signals .....	33
<b>2.2. Ecological and hygienic principles .....</b>	<b>36</b>
2.2.1. Hygienic principles.....	36
2.2.2. Ecological principles .....	36
<b>2.3. Machine preservation and storage .....</b>	<b>37</b>
2.3.1. Short-term preservation and storage for a period of 1 – 2 months .....	37
2.3.2. Preservation and storage for the period over 2 months long .....	37
2.3.3. Dewaxing and inspection of a supplied machine .....	38
<b>2.4. Machine disposal following its life cycle end .....</b>	<b>39</b>
<b>2.5. Machine description.....</b>	<b>41</b>
<b>2.6. Actuators and dashboard instruments.....</b>	<b>42</b>
2.6.1. Power View control .....	56
<b>2.7. Machine control and use .....</b>	<b>69</b>
2.7.1. Starting the engine .....	69
2.7.2. Travel and reversing.....	72
2.7.3. Emergency stop of the Machine .....	75
2.7.4. How to stop the Machine and its engine .....	76
2.7.5. Machine parking .....	77
2.7.6. Cab and bonnet raising and lowering.....	78
2.7.7. Blade.....	81
2.7.8. Filling tyres with water.....	84
<b>2.8. How to transport the Machine.....</b>	<b>86</b>
2.8.1. Machine loading .....	87
<b>2.9. Special conditions of the Machine use.....</b>	<b>88</b>
2.9.1. Machine towing.....	88
2.9.2. Machine operation during running-in.....	91
2.9.3. Machine operation at low temperatures.....	91
2.9.4. Operating the Machine at high temperatures and humidity .....	92
2.9.5. Operating the Machine at high altitudes.....	93
2.9.6. Work of the machine in the dusty environment.....	93
2.9.7. Driving with vibrations on compacted and hard materials.....	93

# Content

---

<b>3. MAINTENANCE MANUAL .....</b>	<b>97</b>
<b>3.1. Safety and other measures for machine maintenance.....</b>	<b>99</b>
3.1.1. Safety of machine maintenance.....	99
3.1.2. Fire precautions during operation media exchanges.....	99
3.1.3. Ecological and hygienic principles .....	100
<b>3.2. Specification of fluids.....</b>	<b>101</b>
3.2.1. Engine oil .....	101
3.2.2. Fuel.....	102
3.2.3. Coolant .....	103
3.2.4. Hydraulic oil.....	103
3.2.5. Gearbox oil .....	104
3.2.6. Lubricating grease.....	104
3.2.7. Windshield washer liquid .....	104
3.2.8. Vibrator cooling mixture .....	104
<b>3.3. Fills.....</b>	<b>105</b>
<b>3.4. Lubrication and Maintenance Chart .....</b>	<b>106</b>
<b>3.5. Lubrication Chart.....</b>	<b>108</b>
<b>3.6. Individual Operations of Maintenance .....</b>	<b>109</b>
<b>After 20 hours of operation (daily).....</b>	<b>110</b>
3.6.1. Engine oil level check.....	110
3.6.2. Engine cooling liquid level check .....	111
3.6.3. Hydraulic tank oil level check.....	112
3.6.4. Crankcase breather tube.....	112
3.6.5. Check of the fan and engine belt condition .....	113
3.6.6. Checking the vacuum valve of the air cleaner .....	114
3.6.7. Checking warning and control devices .....	115
<b>After 100 hours of operation (weekly).....</b>	<b>116</b>
3.6.8. Checking the tyre pressure .....	116
<b>After 250 hours of operation (3 months).....</b>	<b>117</b>
3.6.9. Checking the engine inlet piping .....	117
3.6.10. Check of the fan and engine belt condition .....	118
3.6.11. Check of coolers .....	119
3.6.12. Battery check.....	120
3.6.13. Air filter sensor check .....	122
3.6.14. Lubrication of the machine.....	123
3.6.15. Checking oil in the vibrator.....	126
3.6.16. Checking oil in gearboxes.....	127
3.6.17. Inspect the pad foot segments.....	128
<b>After 500 hours of operation (after 6 months).....</b>	<b>129</b>
3.6.18. Replacing oil in the engine.....	129
3.6.19. Fuel filter replacement.....	132
3.6.20. Engine cooling liquid check.....	134
3.6.21. Checking tightening bolts of wheel .....	134

<b>After 1,000 hours of operation (after 1 year) .....</b>	<b>135</b>
3.6.22. How to check tightening pulley and belt of the engine.....	135
3.6.23. Oil exchange in the travel gearboxes .....	137
3.6.24. Checking the damping system .....	139
<b>After 2,000 hours of operation (after 2 years).....</b>	<b>141</b>
3.6.25. Checking, adjusting the valve clearance.....	141
3.6.26. Oil exchange in the vibrator .....	141
3.6.27. Exchanging hydraulic oil and filter.....	142
3.6.28. Cab and bonnet raising and lowering suction strainer unit cleaning .....	146
3.6.29. Exchanging the engine cooling liquid .....	147
<b>Maintenance - As Needed .....</b>	<b>149</b>
3.6.30. Exchanging cleaner elements of air cleaner .....	149
3.6.31. Cleaning of the water separator on the fuel filter .....	151
3.6.32. Cleaning of coolers.....	152
3.6.33. Cleaning the air cleaner of cabin ventilation.....	153
3.6.34. Cleaning the machine .....	154
3.6.35. Adjusting scrapers.....	155
3.6.36. Vibrator cooling mixture .....	155
3.6.37. Check of the screw connection tightening .....	156
<b>3.7. Defects.....</b>	<b>159</b>
<b>3.8. Annexes .....</b>	<b>160</b>
Wiring diagram.....	160
Hydraulic system diagram - INTER - Wheel differential lock .....	166
Hydraulic system diagram - Interaxle differential lock ATC .....	168

---

# **1. SPECIFICATION MANUAL**

## **ASC 150 (Cummins Tier 3)**

## 1.1. Basic Data

### Machine description

Single drum roller with an articulated frame with a front smooth or padfoot steel driven vibrating drum and driven rear axle with two treaded tyres. Steering using the articulated frame.

### Machine application

**ASC 150** rollers are suitable for medium and large-sized compaction works in transport construction (motorways, railways, airfields), water resources construction (rockfill dams), and building construction (industrial zones, harbours), etc.

**ASC 150 D** roller with a smooth drum is suitable for the compaction of all kinds of soils. It is possible to be used for the compaction of clay soils up to a layer thickness (after compaction) of 30 cm (11.8 in), loam soils up to a layer thickness of 50 cm (19.7 in), mixed soils up to a layer thickness of 70 cm (27.5 in), sandy and gravel materials up to a layer thickness of 80 cm (31.4 in), and rockfill up to a layer thickness of 120 cm (47.2 in). The maximum permissible grain size in a loose layer is 2/3 of the layer thickness. The roller can also be used for compaction by means of stabilisation.

**ASC 150 PD** roller with a padfoot drum (synchronous kneading and vibrating effect) is suitable for the compaction of clay soils up to a layer thickness (after compaction) of 35 cm (13.7 in), loam soils up to a layer thickness of 50 cm (19.7 in), and mixed soils up to a layer thickness of 70 cm (27.5 in).

**ASC 110/150 HD** roller with an increased pulling force – smooth drum.

**ASC 150 HDPD** roller with an increased pulling force – padfoot drum.

**ASC 150 HT** roller for permanently difficult conditions and on slopes above 30% – smooth drum.

**ASC 150 HTPD** roller for permanently difficult conditions and on slopes above 30% – padfoot drum.

**ASC 150 PDB** roller with a padfoot drum and blade for spreading materials. The blade is the optional equipment supplied per order.

The machines are intended for operation in conditions of the following types according to ČSN IEC 721-2-1 (038900): WT, WDr, MWDr (i.e. mild, warm dry, hot dry with a limited temperature range of from -15 °C (5 °F) to +45 °C (113 °F).

The standard type of the machine is not intended for road traffic. For more information, please contact your dealer.

### Please fill in the following data:

(see Pin label, Label of the CUMMINS engine)

Type of machine

ICV/PIN (Serial number of the machine)

Production year

Type of engine

Serial number of the engine

Please refer to the data in the table below always when approaching the dealer or the manufacturer.

The machine that complies with the requirements as to health protection and safety is identified with a name plate with CE marking.

- 1 - Name – always mentioned only in the English version
- 2 - Type
- 3 - Version
- 4 - Serial number
- 5 - Operating weight
- 6 - Maximum weight
- 7 - Rated power
- 8 - Front axle load
- 9 - Rear axle load
- 10 - Year of manufacture



### Name plate location

- 1 - Name plate
- 2 - Machine frame number

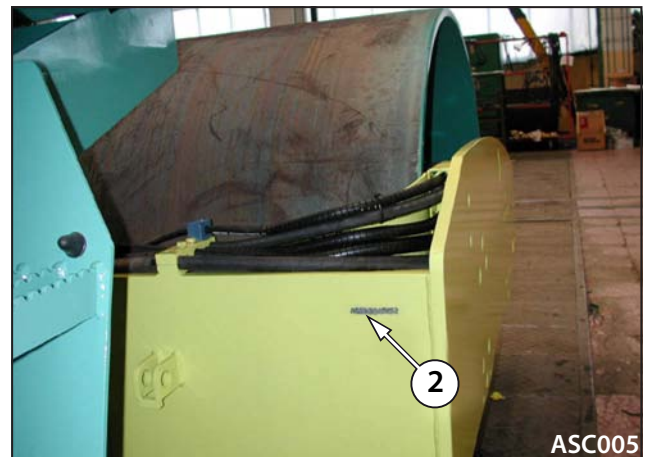
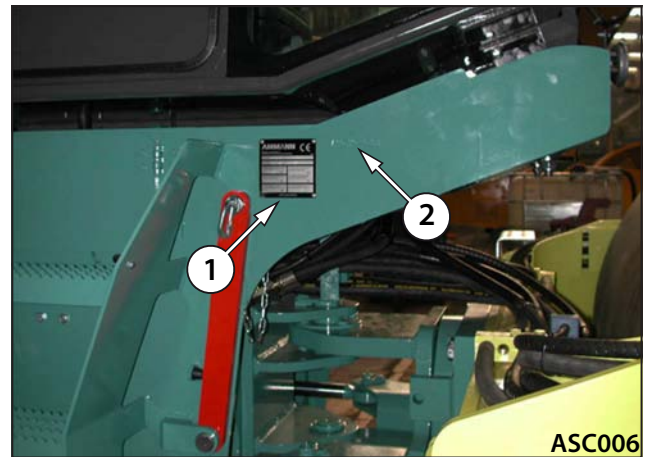

### Engine name plate location



## 1.2. Dimension Chart

Dimension Chart of the Machine ASC 150 (with cab and ROPS frame and blade)

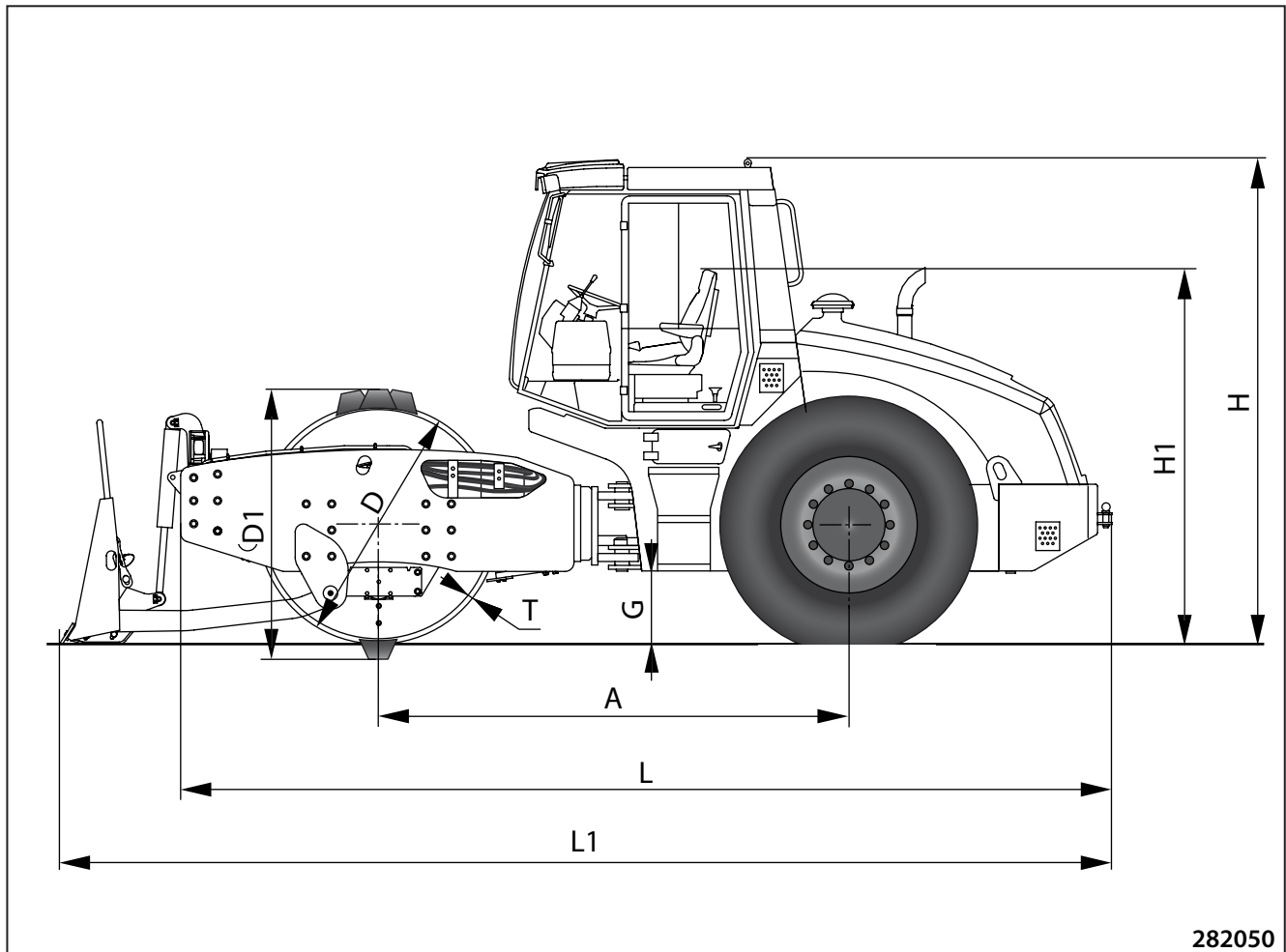

282050

mm (in)	A	D	D1	G	G1	H	H1	L	L1	T	W	W1	W2
<b>ASC 150 D</b>	2930	1500	-	440	435	3075	2420	5900	-	40	2130	2258	-
	(115,4)	(59,1)	(-)	(17,3)	(17,1)	(121,1)	(95,3)	(232,3)	(-)	(1,6)	(83,8)	(88,9)	(-)
<b>ASC 150 PD</b>	2930	1440	1640	440	435	3075	2420	5900	-	28	2130	2258	-
	(115,4)	(56,7)	(64,6)	(17,3)	(17,1)	(121,1)	(95,3)	(232,3)	(-)	(1,1)	(83,8)	(88,9)	(-)
<b>ASC 150 PD</b>	2930	1440	1640	440	435	3075	2420	5900	6650	28	2130	2258	2441
	(115,4)	(56,7)	(64,6)	(17,3)	(17,1)	(121,1)	(95,3)	(232,3)	(261,8)	(1,1)	(83,8)	(88,9)	(96,1)

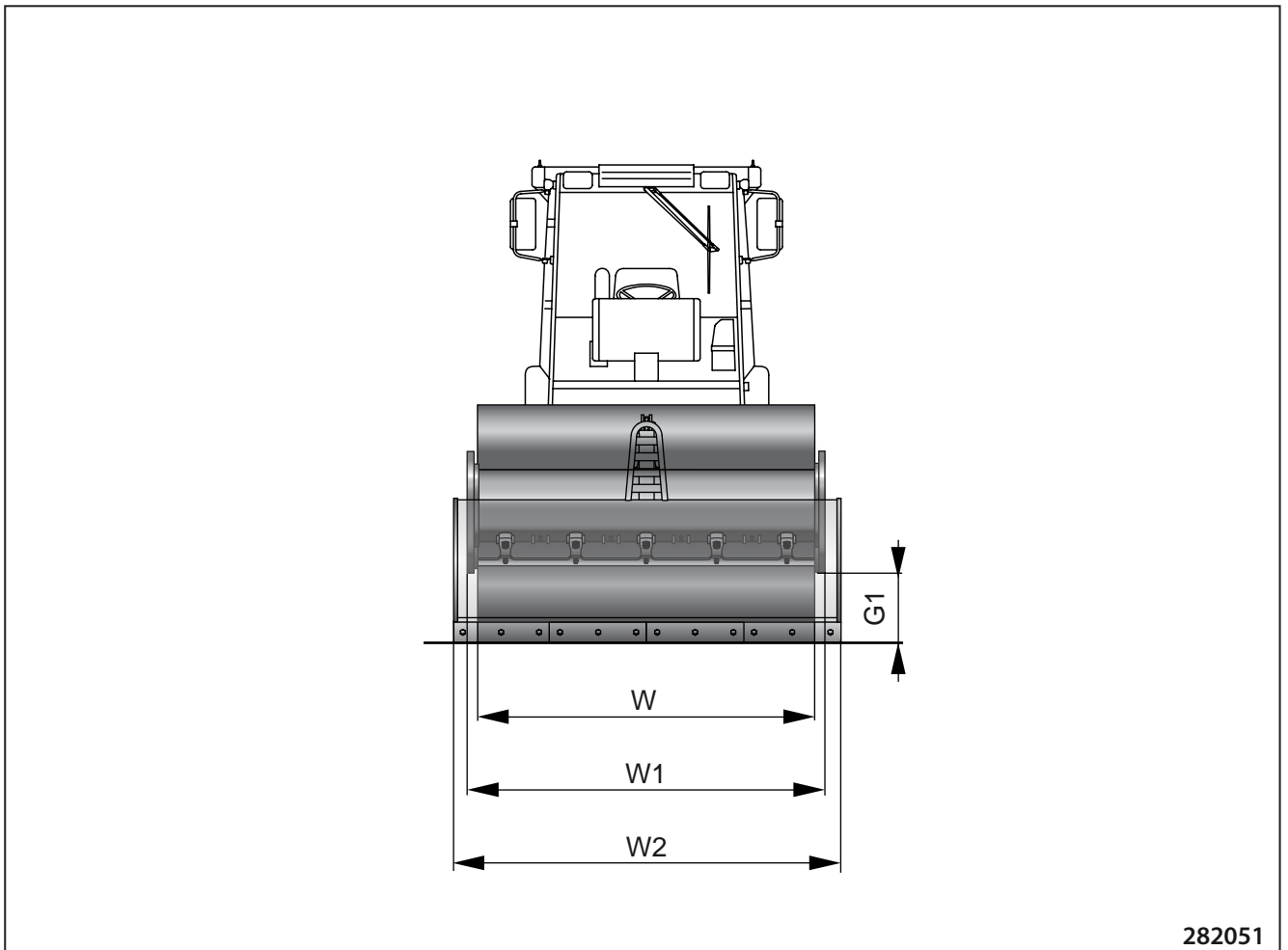

mm (in)	A	D	D1	G	G1	H	H1	L	L1	T	W	W1	W2
<b>ASC 150 D</b>	2930	1500	-	440	435	3075	2420	5900	-	40	2130	2258	-
	(115,4)	(59,1)	(-)	(17,3)	(17,1)	(121,1)	(95,3)	(232,3)	(-)	(1,6)	(83,8)	(88,9)	(-)
<b>ASC 150 PD</b>	2930	1440	1640	440	435	3075	2420	5900	-	28	2130	2258	-
	(115,4)	(56,7)	(64,6)	(17,3)	(17,1)	(121,1)	(95,3)	(232,3)	(-)	(1,1)	(83,8)	(88,9)	(-)
<b>ASC 150 PD</b>	2930	1440	1640	440	435	3075	2420	5900	6650	28	2130	2258	2441
	(115,4)	(56,7)	(64,6)	(17,3)	(17,1)	(121,1)	(95,3)	(232,3)	(261,8)	(1,1)	(83,8)	(88,9)	(96,1)

## 1.3. Technical Data

---

### 1.3.1. Weight

		<b>ASC 150 D</b>	<b>ASC 150 PD</b>
Operation weight EN500-1 with cab and protective frame ROPS	kg (lb)	15210 (33532)	15115 (33322)
to drum	kg (lb)	10910 (24052)	10815 (23842)
to axle	kg (lb)	4300 (9480)	4300 (9480)
		<b>ASC 150 HD</b>	<b>ASC 150 HDPD</b>
		<b>ASC 150 HT</b>	<b>ASC 150 HTPD</b>
Operation weight EN500-1 with cab and protective frame ROPS	kg (lb)	16445 (36254)	16350 (36045)
to drum	kg (lb)	10945 (24129)	10850 (23920)
to axle	kg (lb)	5500 (12125)	5500 (12125)

Operating weight according to EN 500 is weight of the machine with full operating liquid, half filling of fuel, water tank of sprinkling and operator's weight 75 kg (165 lb).

The operating weight of the machine according to ISO 6016 is the weight with fuels and lubricants and watering tank fully filled and with an operator (75 kg /165 lb/). It is calculated by adding 170 kg (374 lb).

The weights may differ depending on additional modifications of the machine made on special request of the customer or if additional options and/or accessories are used.

The maximum permissible weight of the machine including equipment and accessories is 18500 kg (40785 lb).

Blade weight	kg (lb)	+825 (1819)
Weight of 2 sheep-foot segments	kg (lb)	+1745 (3759)
Weight of tyres filled with water	kg (lb)	+1200 (2646)

## 1.3.2. Riding characteristics

Drive type		Hydrostatic	
Number of working speeds		3	
Number of transport speeds		1	
Maximum gradient when towing the machine on the slope	%	60	
Approach angle - front	%	62	
Approach angle - rear	%	53	
Turning radius outer (contour)	mm (in)	6085 (239,6)	
Turning radius outer (edge)	mm (in)	3715 (146,2)	
		<b>ASC 150 D</b>	<b>ASC 150 PD,HD HT,HDPD,HPD</b>
Lateral static stability	%	65	75
		<b>ASC 150 D</b>	<b>ASC 150 PD</b>
Maximum speed in both directions	km/h (MPH)	10.0 (6.2)	10.1 (6.27)
		<b>ASC 150 HD</b>	<b>ASC 150 HDPD</b>
Maximum speed in both directions	km/h (MPH)	8.1 (5.0)	8.2 (5.1)
		<b>ASC 150 HT</b>	<b>ASC 150 HTPD</b>
Maximum speed in both directions	km/h (MPH)	7.0 (4.35)	7.0 (4.35)

## 1.3.3. Steering

Steering type		Articulated
Steering control		Hydraulic
Linear hydraulic motors		2
Steering angle in horizontal plane max.	°	(±)36
Frame oscillating angle in vertical plane	°	(±)10

## 1.3. Technical Data

---

### 1.3.4. Motor

Engine make		Cummins Diesel
Engine type		QSB4.5-C160
Number of cylinders		4
Total displacement	cm <sup>3</sup> (cu in)	4500 (275)
Engine power ISO 3046/1 (DIN 6271)	kW (HP)	119 (160)
Nominal speed	min <sup>-1</sup> (RPM)	2200
Maximum torque	Nm (ft lb)	624 (460)/1500 min <sup>-1</sup> (RPM)
Routine operation fuel consumption *	l/h (gal US/h)	19,9 (5,26)

Engine conforms to emission regulations:

Dir. 97/68/EU Stage 3  
EPA/CARB 40 CFR Part 89 Tier 3

\* As per ACZ methodology

### 1.3.5. Axle

Tire size		23,1x26"
Tire inflation	kPa (PSI)	160 (23,2)

### 1.3.6. Brakes

Operation brake	Hydrostatic
Parking and emergency brake	Multiple-disc spring brake

### 1.3.7. Vibration

Drive type		Hydrostatic.
Low frequency	Hz (VPM)	29 (1740)
High frequency	Hz (VPM)	35 (2100)
High amplitude	mm (in)	2.0 (0.079)
Low amplitude	mm (in)	1.0 (0.039)

**1.3.8. Fluid capacities**

Engine oil	l (gal US)	11,0 (2,9)
Cooling system	l (gal US)	32,0 (8,45)
Fuel	l (gal US)	410 (108,3)
Hydraulic system	l (gal US)	90 (23,8)
Drum drive gear-box (ASC 150 HD, HDPD)	l (gal US)	4,8 (1,27)
(ASC 150 HT, HTPD)	l (gal US)	5,1 (1,35)
Wheel gears	l (gal US)	2x2,8 (2x0,74)
Vibratory drum	l (gal US)	8,0 (2,1)
Drum vibrator cooling mixture (up to -25°C)	l (gal US)	80 (21,1)
Tyre liquid mixtures (up to -25°C)	l (gal US)	1200 (2646)
Tank of windscreen washer	l (gal US)	2,75 (0,72)

**1.3.9. Electrical Installation**

Rated voltage	V	24
Capacity of battery	Ah	2 x 100

**1.3.10. Noise and vibration emissions**

**Machine with cab:**

Declared value of acoustic pressure A at the operator's working place:  
(According to EN 500-4+A1 and EN ISO 11201)  $L_{pAd} = 79$  dB

Guaranteed sound power level A (for the machines with „CE“ marking):  
(According to 2000/14/EC and EN ISO 3744)  $L_{WA} = 107$  dB

Highest weighted effective value of acceleration of vibrations transmitted to the whole body:  $a_{wmax} < 0.5$  m.s<sup>-2</sup>  
(According to EN 1032+A1 - gravel)

Total value of vibrations transmitted to hands (vector sum):  
According to EN 1032+A1 - gravel  $a_{hv} < 2.5$  m.s<sup>-2</sup>

## 1.3. Technical Data

---

### 1.3.11. Optional equipment

Air-conditioning

Installation for radio with antenna and loudspeakers

Radio with CD

Electro-hydraulic cab and bonnet lifting

ROPS 2D

Warning beacon

Reversing alarm

Alternator and fan cover

Head and rear lights (including direction indicator lights)

Inter-axle electronic differential lock ATC

Additional padfoot segments (recommended with ATC and tractor tyre)

Blade (recommended with a HD version)

Plates made of Hardox on PD segments

Tractor tyre (as standard with HD, HT, and PD versions)

Loader tyres 23.5x25

Ballasting of tyres with liquid of up to 0 °C

Ballasting of tyres with liquid of up to -25 °C (as standard with HD and HT versions)

Contact scrapers made of Polytan

Engine air pre-filter (Syclone)

Panel with testing points under the platform

Padlock staple above the fuel tank cover

ACI Ammann compaction meter - without memory

ACI compaction meter printer

ADC digital compaction meter with recording memory, printer, and software

ECM compaction meter

Biologically degradable hydraulic oil (Panolin)

Additional documentation

Ammann set of tools

First servicing set (engine and air filters)

Fire extinguisher

Different colour design (Ammann scheme), 1 colour

Special colour design (others)

<b>Notes</b>



## **2. OPERATION MANUAL**

### **ASC 150 (Cummins Tier 3)**

---

### 2.1.1. Safety Measures during Machine Operation

Safety measures given in the individual chapters of Engineering Documentation supplied with the Machine shall be added with Safety Precautions in force within a respective country that uses the Machine at workplace with regard to work organization, work process and personnel involved.

#### 2.1.1.1. Compaction Work Commencement

- Constructional Supplier (Machine User) is liable to issue instructions for driver and maintenance before compaction work is started, that will include requirements on work safety provision during Machine operation.
  
- He must verify and mark:
  - utility lines
  - underground areas (direction, depth)
  - seepage or escape of hazardous materials
  - soil bearing capacity, slope of travelling plane
  - other obstructions incl. their removal.He must make Machine driver, who will carry out earth work, familiar with these conditions.
  
- He must specify Code of Practice (C.O.P.) part of which is work procedure for a given work operation and this work procedure will specify inter alia:
  - measures when working under extraordinary conditions (work within protective zones, within extreme slopes, etc.)
  - precautions for any natural disaster hazards
  - requirements on work performance while observing job safety principles
  - technical and organizational measures to secure safety of personnel, workplace and environment.He must make Machine driver evidently familiar with the Code of Practice.

### 2.1.1.2. Work Safety Secured by User

- User shall promptly communicate any damage to the utility lines to their operator, and at same time he make measures to prevent unauthorized persons from entering endangered area.
  
- He must ensure an employee does not work alone at a workplace. Another worker must always be in sight and within an ear-shot, who in case of accident will provide or call for help unless another effective form of monitoring or communication exists.

## 2.1. Major Safety Precautions

---

### 2.1.1.3 Ensurance of safety measures by the owner

- The owner must ensure that the machine is operated only in such conditions and only for such purposes to which the machine is technically capable according to conditions specified by the manufacturer and relevant standards.
- He must ensure that the roller is used only in such manner and on such working places without a danger to damage the close structures, sections, etc.
- He must ensure a regular inspection of operation and technical conditions, regular maintenance of the machine in intervals specified in the manuals for greasing and maintenance work. In case the technical condition of the machine does not meet the requirements to such extent it endangers safety of operation, people and property or it causes a damage and impairment to the environment, the machine must be put out of service until the defects are removed.
- He must specify who is allowed to carry out operation, maintenance and repairs of the machine as well as what activities can be carried out during the operation, maintenance and repair of the machine.
- The person (driver) who drives the machine and each person carrying out maintenance and repair of the machine must be acquainted with instructions specified in the operation manual of the machine.
- He must ensure that "Operation manual of the machine" and operational book are kept on specified place to be at disposal for the driver all the time.
- He must assign a workman for permanent supervision over the machine work during its operation on public roads and especially he is obliged to issue instructions to ensure safety of works.
- He must ensure that dangerous substances (such as fuel, oils, coolant, break fluid, etc. must be removed from places of leakage according to their nature to prevent from their adverse impact to the environment, safety of operation and health of people.

### 2.1.1.4.ROPS

The following precautions shall be observed while the protection frame ROPS is used:

- The machine frame must not be damaged (broken, bent, etc.) in the place of connection.
- The ROPS frame itself must not show the marks from corrosion, damage through cracks or splits.
- ROPS frame must not be loose during the machine operation.
- All bolted connections must meet the specifications requirements and must be tightened to the moment specified.
- Bolts and nuts must not be damaged, distorted and they must not show the marks from corrosion.
- None additional modifications can be carried out on the ROPS frame without the approval of the manufacturer because they can result in decrease of its strength (e.g. openings, welding, etc.).
- Weight of the machine with the protective frame must not exceed the permitted weight for which ROPS was approved.

### **2.1.2. Requirements on Driver's Qualification**

- Only a driver trained under ISO 7130 and other local and national regulations designed for drivers of this group of machines may operate the Roller (Compacter).
- With no licence only the one who learns driving the Machine for the purpose of getting preliminary practice with the approval of User may drive the Machine, and such person has to be under direct and continuous surveillance of professional teacher or trainer.
- Licence holder is liable to take due care of the licence, and when requested, put it forward to the control authorities.
- Licence holder can make no registrations, changes or corrections in the licence card.
- He/she is liable to promptly report his/her licence loss to the authority that issued this licence.
- Driving the Roller alone may be performed by an employee mentally and physically fit, over 18 years old, who is:
  - a) assigned by machine manufacturer for the assembly, testing and presentation of the Machine, for training the drivers, whereas he/she must be made familiar with safety work regulations in force at the workplace
  - or
  - b) assigned by Constructional Supplier to operate (carry out maintenance) and is evidently trained and acquainted with, or owns professional competence to operate and drive under special regulations (machinist licence, etc.).
- Machine driver must undergo training and examination concerning work safety regulations at least 1x every 2 years.

## 2.1. Major Safety Precautions

---

### 2.1.3. Driver's Liabilities

- Before starting to operate the Machine the driver will be liable to get familiar with the guidelines given in the documentation delivered with the Machine, with safety precautions in particular, and observe these thoroughly. This applies as well to the personnel in charge of maintenance, adjustments and repairs of the Machine.
- Do not drive the Roller unless made familiar with all the Machine functions, working and operating elements, and unless knowing exactly how to control the Machine.
- Follow safety signs located on the Machine, and keep them in legible condition. Replace or add those impaired or missing ones.
- Before work commencement the driver must get familiar with the workplace environment, i.e. with the slopes, utility line system, with necessary types of workplace protections with regard to the environment (noise, etc.).
- When you find out any hazard to health or life of persons, property hazard, failure, or upon technology equipment accident, or when finding any symptoms of such hazards in course of operation, then the driver, unless able to eliminate such hazard by himself/herself, must stop the work and secure the machine against any undesirable start; please attach "MACHINE REPAIR" warning sign onto steering wheel as depicted in Section called "Safety signs used on the machine", report this to the person in charge, and if possible, notify all persons exposed to such danger.
- Before Machine operation startup the driver will be liable to get familiar with the records and operation deviations found out in course of the previous work shift.
- Before work is started he/she must inspect the Machine, its accessories, check up control elements, communication and safety devices, whether these are operable in line with the Manual. When finding out a malfunction that might be hazardous to job safety, and he/she is not able to repair it, then he/she must not start running the machine and instead report such failure to the person accountable.
- During work with the Machine the driver must be fastened with the seat belt. The seat belt and its mounting shall not be damaged!
- When driver finds any defect during operation he/she must immediately stop the Machine, secure it safely against undesired ignition.
- During operation the driver shall follow the Machine run and record any defects found in the Operation Logbook.
- Driver shall keep his/her Operation Logbook designed to maintain records about Machine handover between the drivers, about the defects or repairs in course of operation, to write down major events during work shift.
- Prior turning on the engine the controls have to be in their zero position, no persons may stay within dangerous reach of the Machine.
- Indicate each Machine startup via an acoustic or light signal and this always before igniting the Machine engine.
- Confirm brake function and steering function before starting to run the Machine.
- Following the alarm an operator may start the Machine only when all the workers have left the danger area. At close (blind) workplaces it will be possible to start the operation only after a time necessary to leave danger area has elapsed.
- During Machine operation observe safety regulations, make no action that might endanger work safety, give full attention to Machine steering.
- Respect Code of Practice or instructions of a person responsible.
- When rolling (traversing) the Machine within a workplace adapt your speed to a terrain condition, to a work performed and weather conditions. Watch permanently the clearance so to avoid collision with any obstruction.
- Upon completion or stop of the Machine operation during which driver leaves the Machine, he/she must make measures against unauthorized use of the Machine or against spontaneous starting of the engine. Remove key from the ignition box, disconnect the wiring via disconnecter, lock the cabin, engine bonnet.
- When shutting down the Machine on roads the measures under regulations effective on roads shall be taken.
- When operation is completed, park the Machine at a proper parking place (flat, bearing area) so as not to endanger Machine stability, not to make the Machine interfere with traffic roads, not to expose the Machine to falling objects (rock), and where the Machine is safe against any natural disaster of other kind (floods, landslides, etc.).
- When working with the Machine is ended all the defects, damage to the Machine and any repairs made shall be written down in the Operation Logbook. Upon immediate changing of drivers the driver will be liable to call attention of changing driver to any facts identified.
- Driver shall use personal protective equipment (PPE) - work clothing, safety shoes, the clothing shall not be too loose, impaired, hair protected with proper head piece. During maintenance (lubrication, refilling, replacement of working media) your hands must be protected with proper gloves.
- In the event that the machine has no cab or when the windows are open, the operator must wear ear protectors.
- Driver shall maintain the Machine equipped with fittings and outfit required.
- Maintain the Machine free of oil dirt or flammable materials. Keep the drive's stand, foot rests and runner areas clean.
- When the Machine comes into contact with high voltage observe the following principles:
  - try to leave with the Machine a hazardous zone
  - do not leave driver's stand
  - give warning to others to keep off and not touch the Machine.

## 2.1.4. Banned Operations

### Banned are the following

- Operate the machine in the explosive environment and underground.
- To use the Machine following ingestion of alcoholic beverages or dopes.
- To use the Machine if its operation might put its technical condition, safety (life, health) of persons, facilities or objects, or road traffic and its continuity, at risk.
- Put into operation and use the Machine when other persons are within its hazardous reach - exception is training a driver by lecturer.
- Put into operation and use the Machine when some of its safeguarding device (emergency brake, driving brake, horn, etc.) has been dismantled or damaged.
- To roll and compact at such slopes where Machine stability would be disrupted (turning over). Machine's static stability stated will lower by drive's dynamic effects.
- To roll and compact at such angles of slopes where hazard of soil breaking off (dropping) under the Machine exists, or loss of adhesion followed by uncontrolled slip might occur.
- To control the Machine in some other way than stated in Driving Manual.
- To roll and compact per bearing capacity of subsoil at such a distance from the edge of slope or trenches, where hazard of landslide or shoulder breaking off (dropping) together with the Machine would occur
- To roll and compact with vibration at such a distance from the walls, cuts, slopes, where their slip (slide) would happen and the Machine covered in.
- To compact with vibration at such a distance from buildings or facilities and equipment within which the risk of them being damaged due to vibration transfer impact, would occur.
- To operate the Machine unless driver control stand fixed properly.
- To operate the Machine when engine bay cover is open.
- To move and transport persons on the Machine.
- To operate the Machine when within hazardous reach thereof are other machines or transportation means aside from those that operate in mutual concert with the Machine.
- To operate the Machine at places impossible to see from driver's stand, and where hazard to people or property could occur unless work safety has been secured through some other way like for instance via signalling by duly instructed person.
- To work with the Machine at a protected zone of electric lines or substations.
- To cross electric cables if these are not properly protected against mechanical damage.
- To operate the Machine under lowered visibility or at night, unless Machine's working area and workplace are illuminated sufficiently.
- To leave driver's cockpit of the Machine when the Machine is running.
- Boarding or getting off while on the run, jumping off the Machine.
- Sit or stand on the outside parts of the Machine when driving, or stand on the steps.
- Leave unsecured Machine - move away from the Machine without having prevented its misuse.
- Disable safeguarding, protective or locking systems or alter their parameters.
- Use the Machine with oil, fuel, cooling liquid or other fillings leaking.
- Start the engine through some other way than given in the Driving Manual.
- Locate some other items (tools, accessories) aside from personal needs at driver's stand.
- Lay away material or other objects on the Machine.
- Remove dirt while the Machine is running.
- Perform maintenance, cleaning or repairs with the Machine not secured against spontaneous move or accidental start, and when contact of a person with moving parts of the Machine is not excluded.
- Contact of moving parts of the Machine with human body or objects and tools held in hands.
- Smoke or handle open fire when checking or pumping fuels, refilling oils, lubricating the Machine, or inspecting the accumulator or making up the accumulator.
- Carry rags soaked with flammable materials, or carry flammable liquids in free vessels on the Machine (in engine bay).
- Let the engine run inside confined spaces.
- Drive with open doors.
- Perform any adjustments on the machine without the prior consent of the manufacturer.
- Drive without the seat belt fastened.
- Shift electrical conductors.
- Use other than original spare parts.
- Interfere in the electrical and electronic units in any manner.

## 2.1. Major Safety Precautions

### 2.1.5. Safety inscriptions and signs used on the Machine

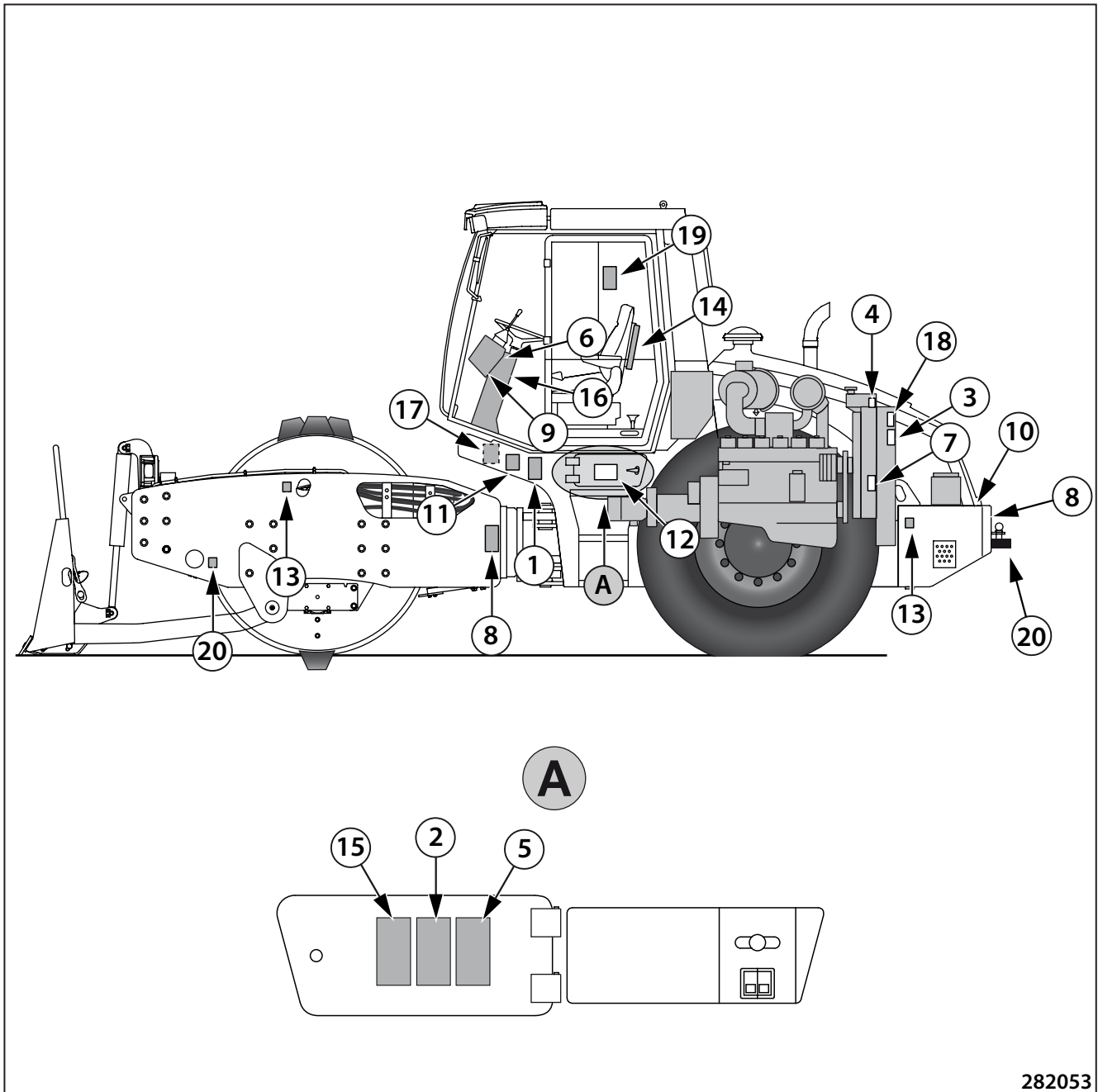

1 Clamping hazard



2941bz

imminent danger of being pressed. (Symbols located left and right on the frame)

2 Burn hazard



2586bz

imminent risk of burn. Do NOT touch hot parts of the Machine unless you make certain these have cooled out sufficiently. (Symbol located from within on the LH door)

3 Risk of injury



2409bz

imminent risk of cutting oneself and/or chipping off. Do NOT touch rotating parts if the engine is running. (Symbol located on LH side of the cooler).

4 Cooling liquid



3227bz

imminent risk of scald. Do NOT open expansion tank lid until liquid cools down below 50 °C (122 °F). (Symbol located on expansion tank)

5 Adjust while at rest



2584bz

Switch OFF the engine and remove the key from ignition box before carrying out any maintenance or repair. (Symbol located from within on LH door)

6 Read Operation Manual



2702bz

Read Operation Manual before starting the Machine. (Symbol located on LH side of the actuator panel)

## 2.1. Major Safety Precautions

7 Risk of injury



Imminent risk of hand caught by belt. (Symbol located on LH side of cooler)

8 Danger zone



Keep a safe distance from the machine! (Symbol located on both sides of the drum frame and on the rear of the machine frame)

9 Safety belt



Fasten the seat belt before starting to move the Machine. (Symbol located on LH side of actuator panel)

10 Danger of explosion



imminent danger of explosion while handling the battery - read Operation Manual. (Symbol located on fuel tank)

11 Machine max height



Attention when passing through places with height limits. (Symbol located on LH side under the cab on frame)

12 Suspension scheme

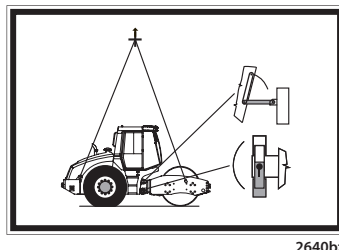

For lifting the machine, use slings with a sufficient capacity, see the Machine loading section. Before suspending, secure the machine joint. (Symbol located on the left door)

13 Lifting points



Sling (hang) the Machine only in these points. (Symbols located along both sides of the frames)

14 Manual



Identification of stowage box to put Machine documentation in. (Symbol located on the back rest of the seat, from the rear)

15 Disconnect alternator



before welding, please disconnect alternator and electronics of the Machine, engine actuator unit. (Symbol located from within on lateral LH door)

16 Ear protectors



Use ear muffs when the Machine has no cab or you work with open windows. (Symbol located on centre steering column)

17 Emitted noise level



Plate located on the right side of the frame under the cab (for the noise level, see the Noise and vibration emissions section)

18 Electric instruments



Cover electric instruments when washing Machine. (Symbol located on LH side of cooler)

## 2.1. Major Safety Precautions

---

19 Emergency exit



Unless possible to exit the Machine via LH door, please use emergency exit. (Symbol located on cab's RH window)

20 Rigging points



Sling the Machine in these points only. The maximum permitted force for fastening the machine to a vehicle using rear slings is 5 t. (Symbols located along both sides of the frames).

21 Machine repair



Do NOT start the engine! Hang the sign onto steering wheel. The sign is supplied together with machine accessories and should be kept in documentation locker.

**2.1.6. Hand signals**

Signals given by an assistant operator if the operator cannot see the travelling or working area or machine work devices.

**SIGNALS USED FOR ALL THE COMMANDS**

**Stop**

One arm stretched upward with open palm in the Operator direction, second arm akimbo.

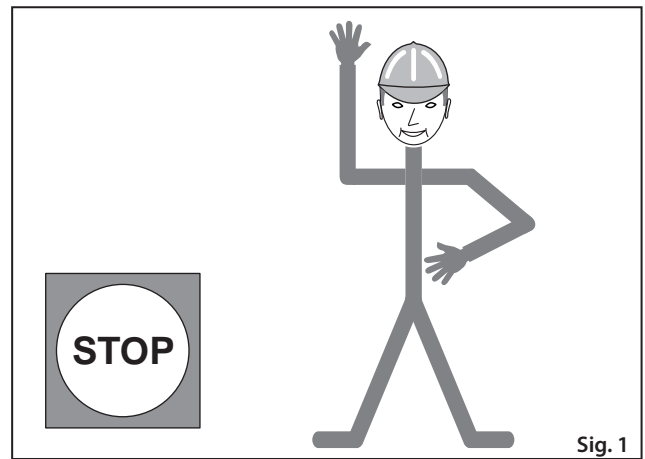

Sig. 1

**Attention!**

Both arms horizontally sideways raised - palms facing forward.

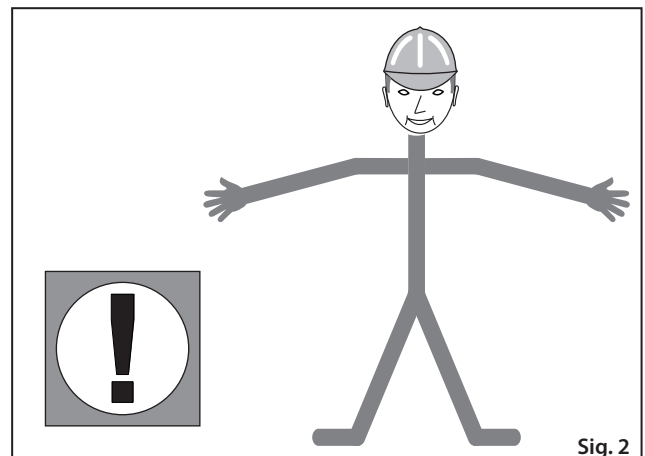

Sig. 2

**Attention, Danger!**

Oscillating motion of both arms with antebrahium from the position of arms horizontally sideways raised to the position or arms sideways raised - bent and back.

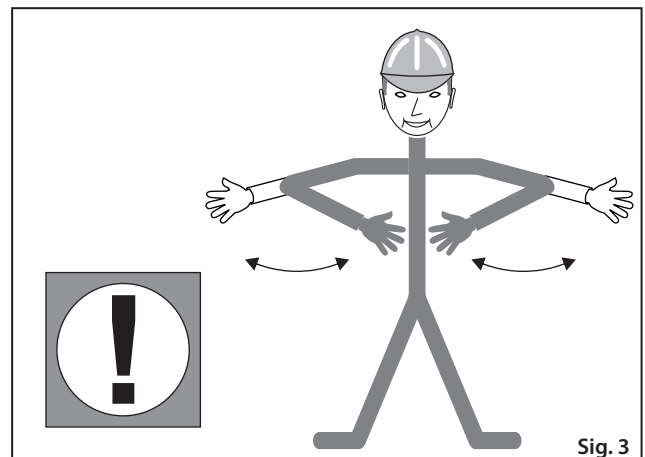

Sig. 3

**SIGNALS FOR DRIVING**

**Drive away with the Machine**

One arm stretched upward - bent with open palm, long motion of antebrahium in the direction of the movement required, second arm akimbo.

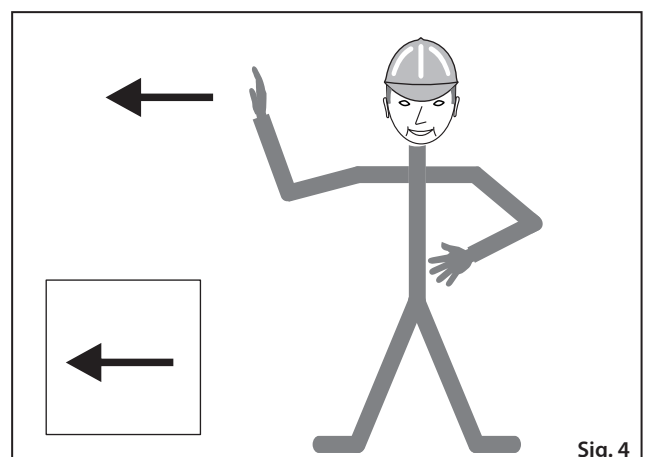

Sig. 4

## 2.1. Major Safety Precautions

### Slow driving forward - towards me

Both arms stretched upward, abreast, bent, with palms facing the body - short oscillating motions of antebrachium, towards the body, and back.

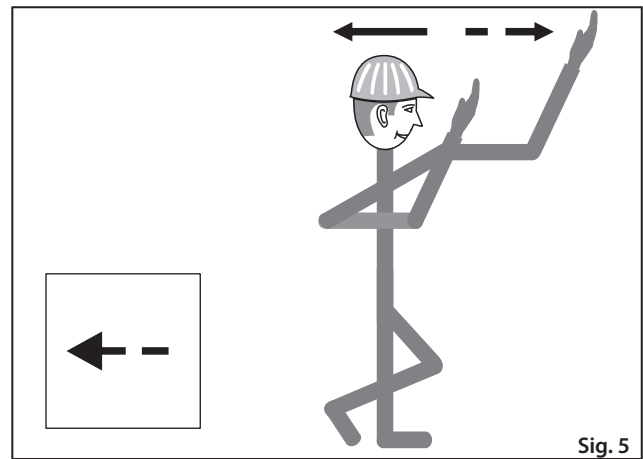

### Slow driving backward - away from me

Both arms stretched upward, abreast, bent, with palms away from the body - short oscillating motions of antebrachium away from the body, and back.

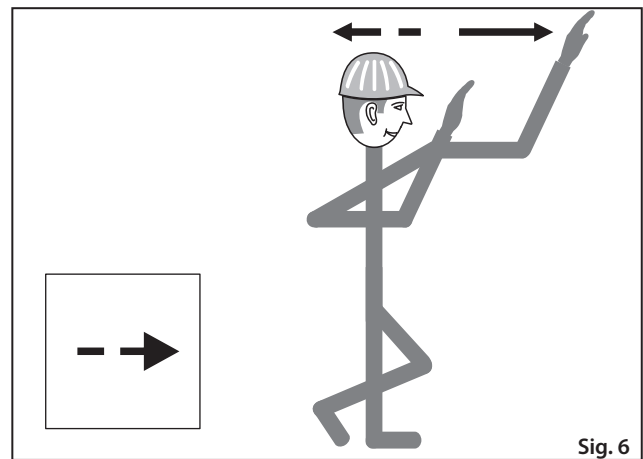

### Driving on the right

Left arm sideways raised, right arm akimbo.

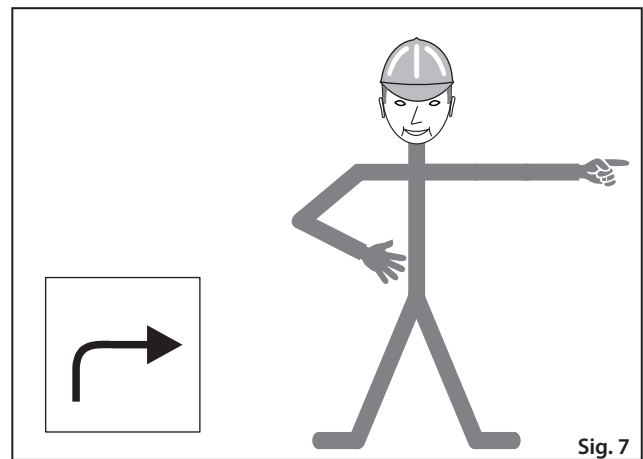

### Driving on the left

Right arm sideways raised, left arm akimbo.

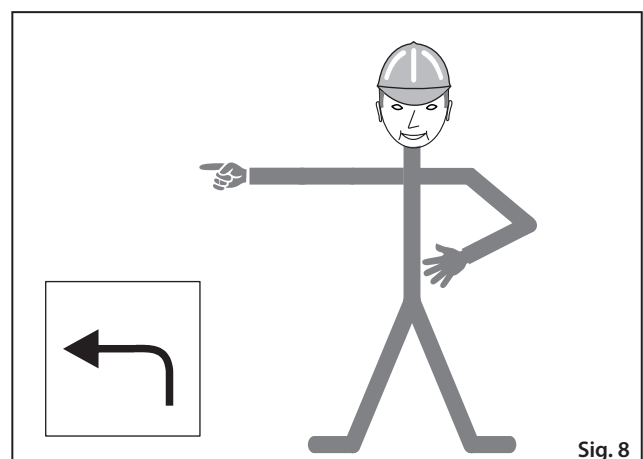

## Short motion

Both arms lifted forward, bent. Mark distance "X" between palms, then follows the motion signal.

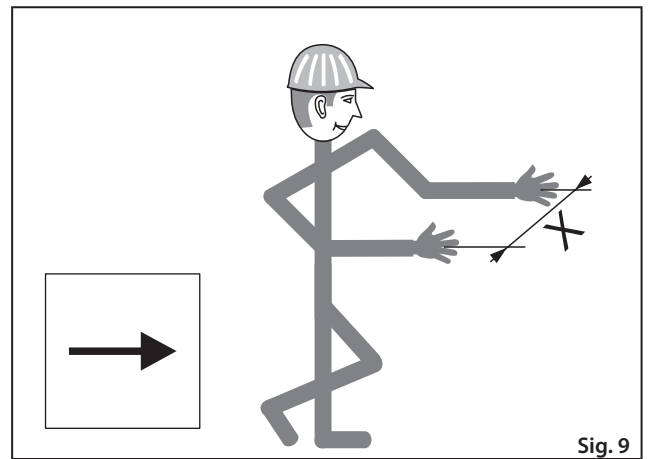

## Engine start

Circular motion of antebrachium of right hand, with tight fist.

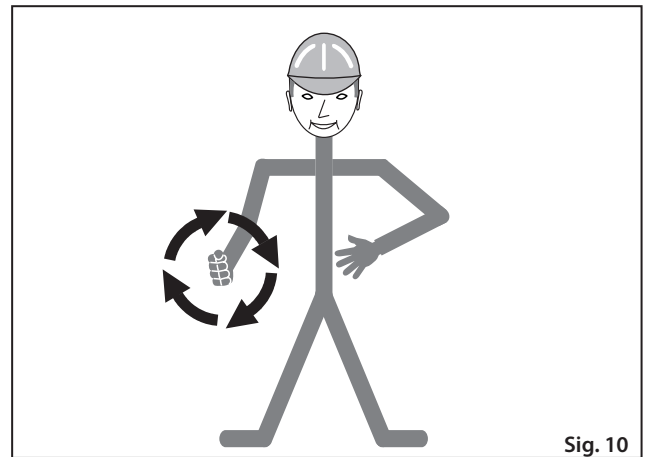

## Engine cut off

Oscillating motion of right hand sideways raised in front of the body, to the sides.

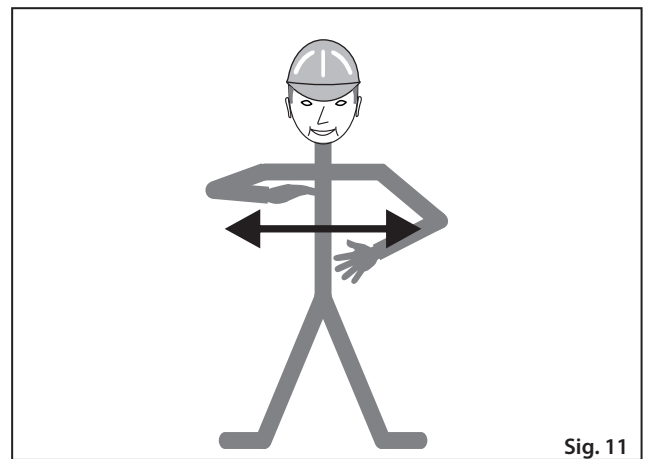

## 2.2. Ecological and hygienic principles



**When operating and storing the Machine the User shall be liable to adhere to the general principles of health and environment protection, as well as the laws, regulations, and rules related to this issue, and effective within the territory where the Machine will be used.**

### 2.2.1. Hygienic principles

- Oil products, cooling system media, battery media, and coating compositions incl. thinners are deleterious materials. Persons that come into contact with these products during Machine operation and maintenance shall be liable to follow general principles of own health protection and conform to the safety and hygienic directions from manufacturers of these products.

Observe the following in particular:

- Eye and skin protection when handling the batteries
  - Skin protection when handling oil products, coating compositions and cooling liquids
  - Wash your hands thoroughly upon work completion and before meal, treat your hands with proper tissue cream
  - When handling the cooling systems, please observe instructions given in the Operation Manual supplied with the Machine.
- 
- Always store oil products, cooling system media, battery media and coating compositions incl. organic thinners, and the cleaning and preservation agents as well, in their original properly marked packages. Admit no storage of these materials in unidentified bottles or other vessels with regard to the risk of being interchanged. Especially hazardous is the potential of interchanging for eatables or drinks.
  - If skin, mucosa or eyes are stained accidentally, or vapours inhaled, promptly apply the first aid principles. Get prompt medical attention upon accidental ingestion of these products.
  - When operating the Machine in cases of no cab mounted, or cab windows opened, always use ear muffs of proper type and version.

### 2.2.2. Ecological principles

- When discarded, the media for Machine's individual systems and some of the Machine's parts will become waste of hazardous properties against the environment.

This waste product category includes the following in particular:

- Organic and synthetic lubrication materials, oil and fuels,
  - Cooling liquids,
  - Battery media and the batteries themselves,
  - Tyre media
  - Cleaning and preservation agents,
  - All filters and filter elements removed,
  - All used and discarded hydraulic and fuel hoses, metal rubbers or other Machine's elements contaminated by the abovementioned products.
- 
- Manufacturer and Manufacturer-accredited contracting service organizations or dealers take back these used materials or parts without cost:
    - oils
    - batteries
    - tyres



**The mentioned materials and parts, when discarded, shall be handled in line with relevant national regulations to protect individual components of environment, and in conformity with the health protection regulations.**

## 2.3. Machine preservation and storage

### 2.3.1. Short-term preservation and storage for a period of 1 – 2 months

Wash and clean thoroughly the entire Machine. Before shutting down the Machine for preservation and storage, please heat the engine to its operating temperature while running. Park the Machine on paved, flat surface, in safe location with no danger of damage to the Machine due to natural disasters (floods, landslides, fire origination, etc.).

#### In addition:

- Repair spots where paint has been impaired,
- Lubricate all lubricating points, actuator cables (cable assemblies), joints of the actuators, etc.,
- Check water media have been drained,
- Confirm cooling liquid has the antifreezing properties required,
- Check condition of the battery charges; let them be recharged if required,
- Spread chromated surfaces of piston rods with preservation fat,
- We recommend to protect your Machine against corrosion through spraying the preservation agent (spray-applied), and this especially in places of corrosion hazard.

The Machine treated like that needs no special preparation (set-up) before its subsequent putting into operation.

### 2.3.2. Preservation and storage for the period over 2 months long

To shut down the Machine the same principles apply like with short time preservation.

In addition, we recommend the following:

- Remove the batteries, check their condition and store in cold, dry room (recharge the batteries on regular basis),
- Bottom the drum frame up so the damping system has minimal sag,
- Protect rubber elements with paint using special preservation agent,
- Inflate tyres to their required pressure, and protect against sun radiation effects,
- Spread preservation fat over piston rods' chromated surfaces,
- Preserve the Machine through spraying with special agent, and this particularly in places of possible corrosion,
- Blind the induction manifold and exhaust of the engine with double PE foil, attach thoroughly with adhesive tape,
- Protect headlamps, external back mirrors and other elements of external wiring through spraying with special agent and wrapping in PE foil,
- Preserve engine according to the Manufacturer's Directions - mark visibly the engine has been preserved.



**Following 6 months we recommend to inspect the condition of preservation and renew it if required.**

**If storing the Machine under field conditions, please check the parking place is not exposed to any flooding hazard due to deluges, or whether any other type of risk occurs within such area!**

**NEVER start the engine in course of storage!**



**Before restoration of the Machine service, please dewax and wash the preservation agents away with high pressure stream of hot water added with normal degreasers while observing Directions for Use along with ecological principles.**

**Carry out dewaxing and washing of the Machine at places equipped with collection sumps to catch rinsing water and dewaxing agents.**

## 2.3. Machine preservation and storage

---

### 2.3.3. Dewaxing and inspection of a supplied machine

Check the Machine according to the shipping documents.

Check no parts of the Machine have been damaged during transportation, and that no parts are missing. Inform shipper about any deficiencies.



**Before restoration of the Machine service, please dewax and wash the preservation agents away with high pressure stream of hot water added with normal degreasers while observing Directions for Use along with ecological principles.**

**Carry out dewaxing and washing of the Machine at places equipped with collection sumps to catch rinsing water and dewaxing agents.**

## 2.4. Machine disposal following its life cycle end

---

Upon Machine disposal following its life cycle end the User shall be liable to follow the national regulations, waste acts and environmental policy acts. We therefore recommend to always contact:

- Specialized companies with relevant authorization to deal with these operations,
- Machine Manufacturer or Manufacturer-appointed accredited contracting service organization.



**Manufacturer bears no responsibility for any damage caused to Users' health or for any damage to environment due to non-adherence to the aforementioned warning.**

---

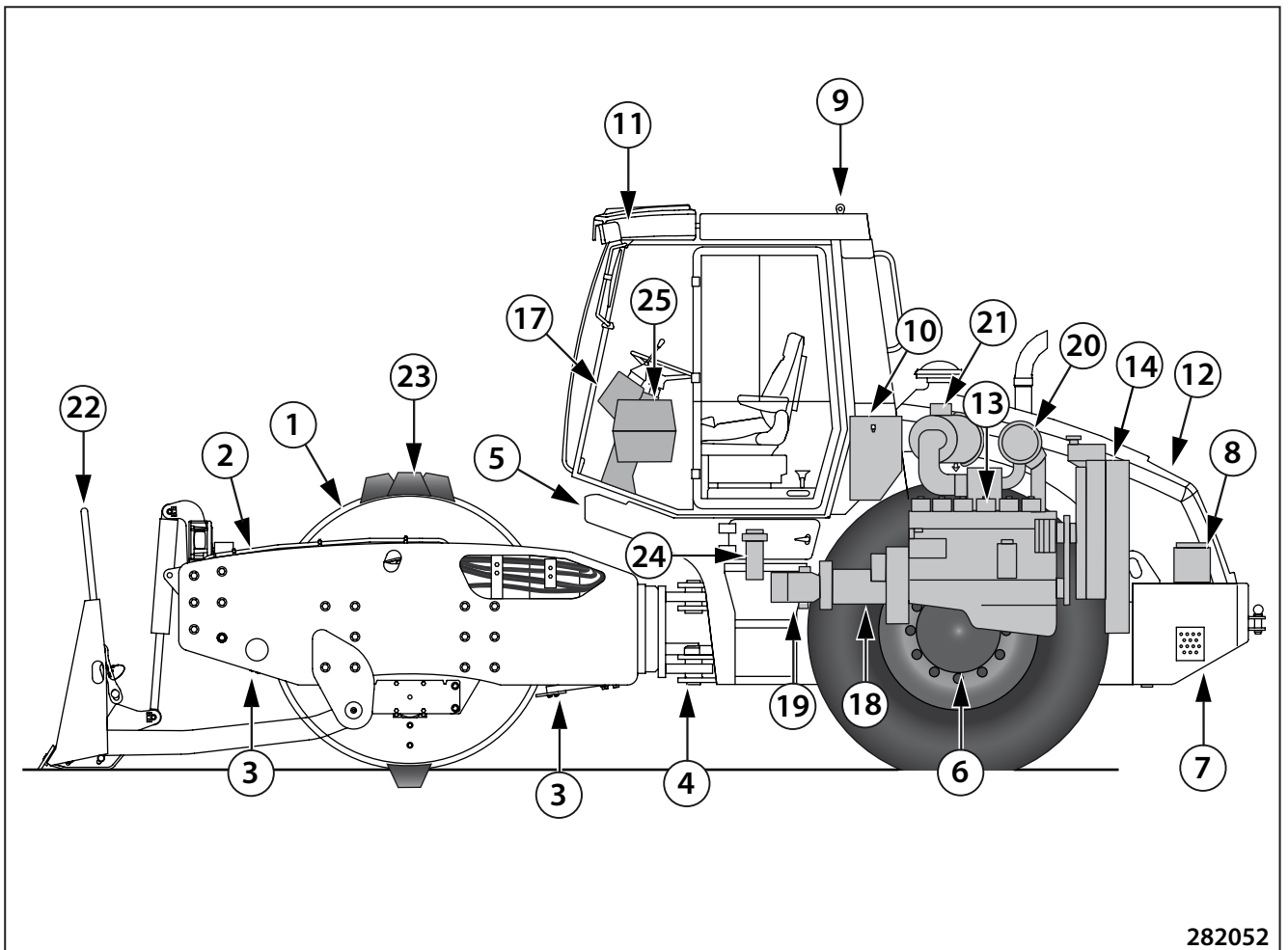

282052

- |                           |  |
|---------------------------|--|
| 1 - Vibratory drum        | 14 - Engine cooler                         |
| 2 - Drum frame            | - Cooler for engine air induction manifold |
| 3 - Scraper               | - Hydraulics cooler                        |
| 4 - Joint                 | 17 - Driver's actuator stand               |
| 5 - Tractor frame         | 18 - Travel hydrogenerator                 |
| 6 - Axle                  | 19 - Vibration hydrogenerator              |
| 7 - Fuel tank             | 20 - Exhaust muffler                       |
| 8 - Batteries             | 21 - Air filter                            |
| 9 - ROPS protection frame | 22 - Plough blade                          |
| 10 - Hydraulic tank       | 23 - Padfoot segments                      |
| 11 - Cab                  | 24 - Hydraulic oil pressure filter         |
| 12 - Bonnet               | 25 - Air Conditioner                       |
| 13 - Engine               |  |

## 2.6. Actuators and dashboard instruments

### Layout of actuator elements and cab accessories - with no air conditioner

- 1 - Windshield washer switch
- 2 - Fan switch - fan induces ambient air
- 3 - Front wiper switch
- 4 - Rear wiper switch
- 5 - Cab light
- 6 - Ventilation nozzles
- 7 - Sun visor
- 8 - Stowage box for first aid kit, operation logbook, etc.
- 9 - Back mirrors - able to fold for transport position by 90° towards cab

#### Note

Rollers fitted with air conditioner have Air Conditioner Operation Manual apart.

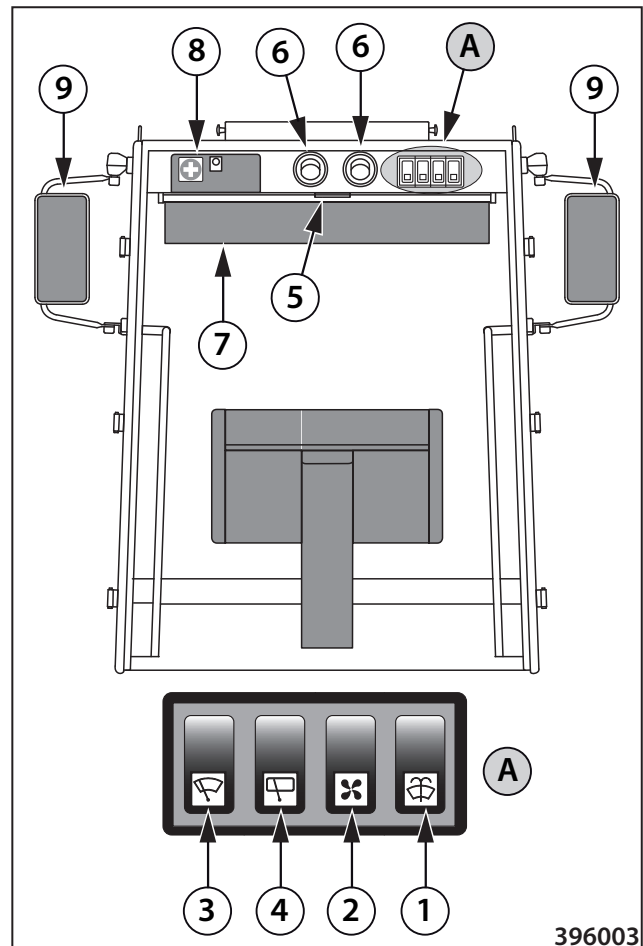

- 11 - Socket for beacon, for hand lamp
- 13 - Battery disconnecter
- 14 - Cab lifting / lowering switch (OPTION)
- 15 - Bonnet lifting / lowering switch (OPTION)
- 16 - Fuse for lifting actuator - cab/bonnet lowering 50 A (OPTION)
- 17 - Manual hydrogenerator for lifting / lowering
- 18 - Manual hydrogenerator joy stick
- 19 - Heater valve tie rod
- 20 - Heater breaths
- 21 - Fire extinguisher (OPTION)\*
- 22 - Washer tank
- 23 - Drink holder
- 24 - Blade actuator hand-type (OPTION)
- 25 - Blade actuator foot-type (OPTION)
- 26 - Lifting levers - cab and bonnet lowering
- 27 - Cab ventilation filter
- 28 - Beacon
- 29 - Front wiper incl. screen washer
- 30 - Rear washer incl. screen washer

\* Place for the installation of a fire extinguisher holder.

#### ! ATTENTION !

The manufacturer recommends that the machine be equipped with a fire extinguisher.

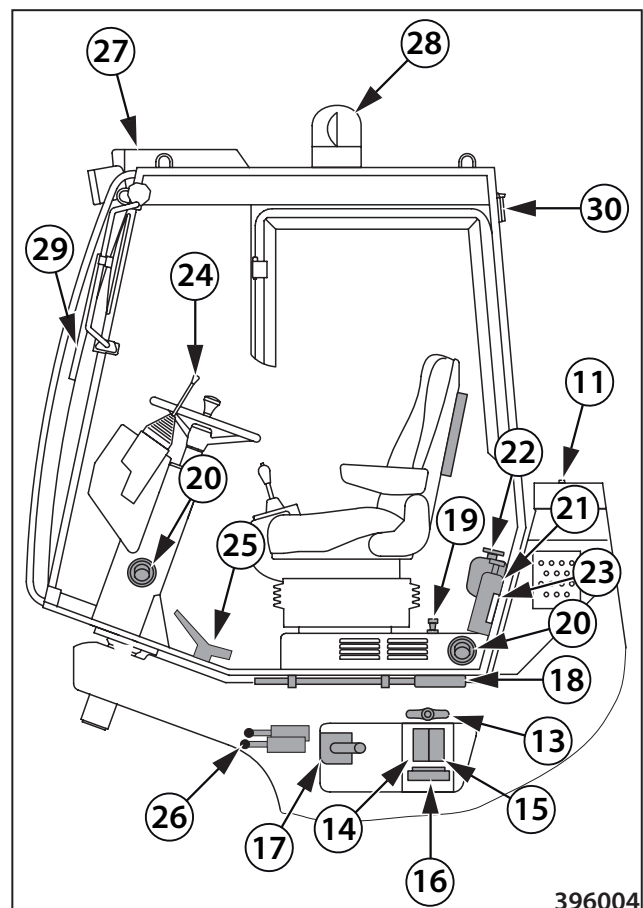

## Driver's seat

Seat adjustment:

- 1 Backrest position
- 2 Arm rest position and folding
- 3 Seat swivel
- 4 Seat sliding (shift)
- 5 Seat squab sliding (shift)
- 6 Seat cushion stiffness as per Driver weight indicator
- 7 Seat height - please, grasp underneath seat squab and lift slowly to adjust seat height to next higher position, 0 ÷ MAX, which will be locked (it clicks). When lifted to highest position the seat will drop again to lowest position.

- 8 Lumbar bolster



**Adjust your seat and fasten your seat belt before driving off!**



### Document compartment

A document compartment is located on the rear side of the seat back.



## 2.6. Actuators and dashboard instruments

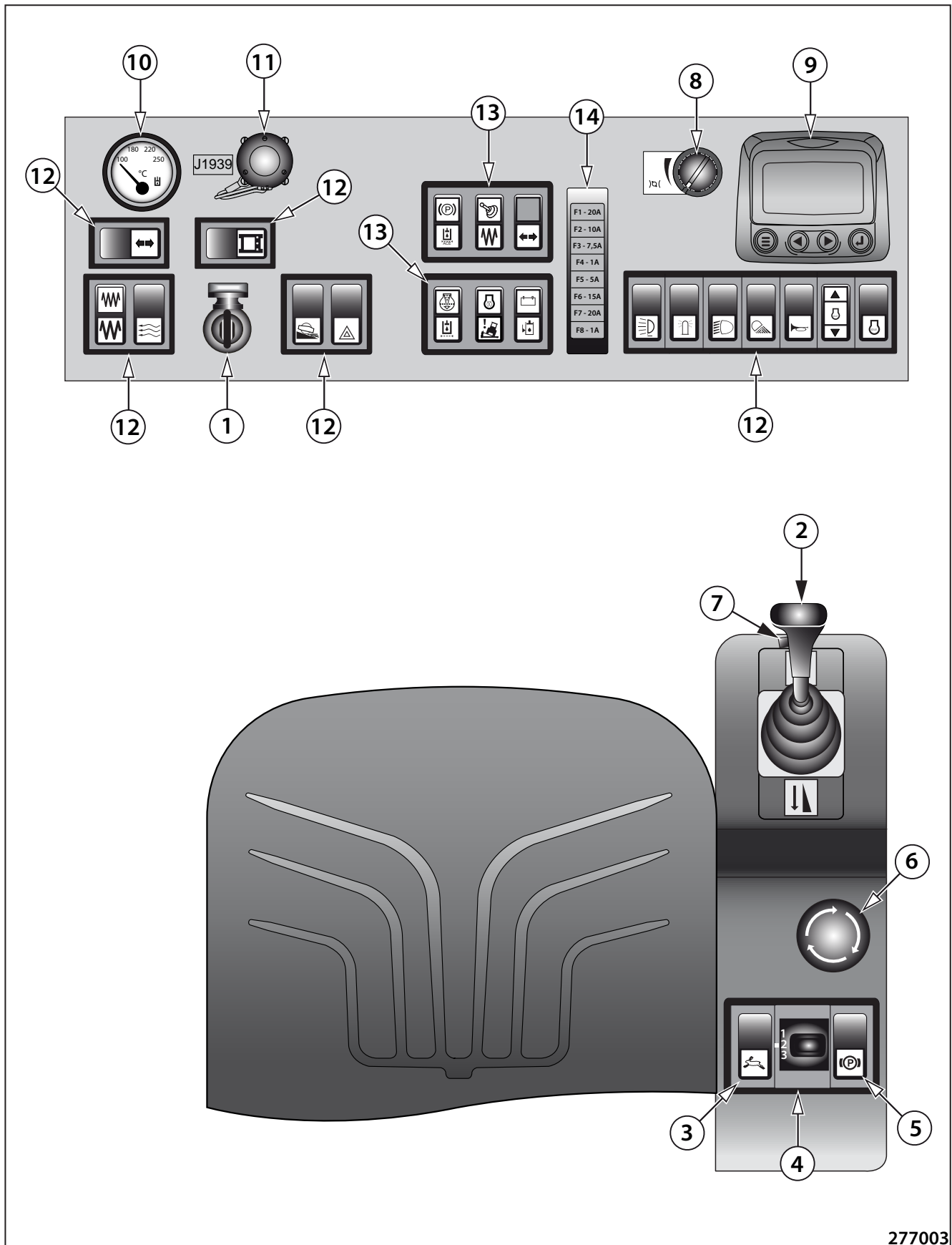

## Dashboard & Actuator Panel

- 1 - Ignition box
- 2 - Travel joy stick
- 3 - Transport speed controller
- 4 - Operating speed preselector
- 5 - Parking brake
- 6 - TOTAL STOP pushbutton (for emergency brake)
- 7 - Vibration switch
- 8 - Engine speed selector
- 9 - Power View Display
- 10 - Hydraulic oil thermometer
- 11 - ECM engine socket
- 12 - Switches
- 13 - Pilot lamps
- 14 - Fuses

### Ignition box 1

While in "0" position the lights, cab/bonnet lifting and AC are connected. While in "I" position the dashboard instruments are connected. Position "II" is used to start the Machine.

#### Note

Ignition key is common for cab door, service door underneath cab, and for tool kit.

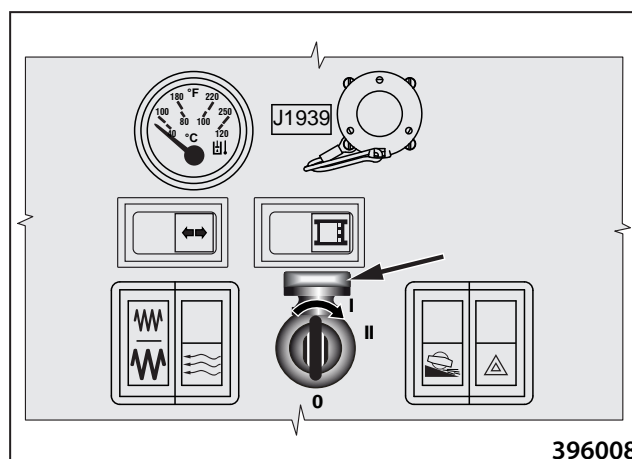

## 2.6. Actuators and dashboard instruments



**Travel joy stick 2**

Use this joy stick to adjust driving direction and speed. Driving speed corresponds to the size of joy stick deflection from neutral position. This joy stick becomes locked in the position adjusted. Joy stick neutral position (N) will be signalled through indicator lamp going on. In the actuator handle there is vibration switch 7 located to turn ON/OFF vibrations.

**! CAUTION !**

**Adjust joy stick to neutral before engine start.**

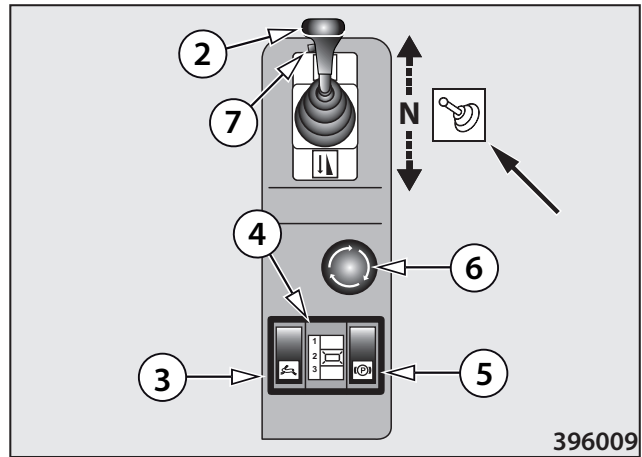

396009



**Transport speed controller 3**

You may switch ON the controller while driving. Roller can reach max speed at reduced tractive force.



**Operating speed preselector 4**

Use this preselector to choose three operating speeds while driving. Transport speed controller must be switched OFF.



**Parking brake 5**

Use this brake to stop the Roller if the engine is to keep running. In this case Driver may stand up from the seat and leave the Roller.

**Note**

Unless standing Roller is braked and Driver stands up from the seat, the Roller will brake and engine will shut off after 8 seconds.



**TOTAL STOP pushbutton 6**

Press this button to stop and brake the Roller, and to shut off the engine.

**! CAUTION !**

**Brake off in arrow direction before starting the engine.**



**Use only in case of emergency during a failure when the Roller is unable to stop through resetting the travel actuator.**

**Vibration switch 7**

Vibration is able to be switched ON while driving.



**Engine speed selector 8**

It is used to adjust the combustion engine speed from max to min.

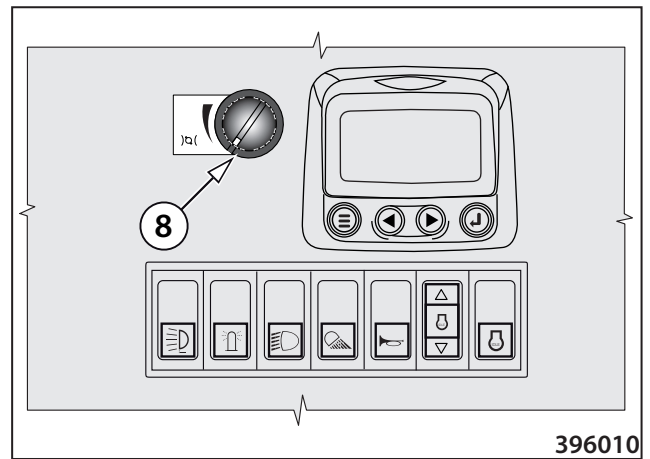

396010

**Power View Display 9**

Multifunctional instrument to display parameters of the engine function and fuel level.

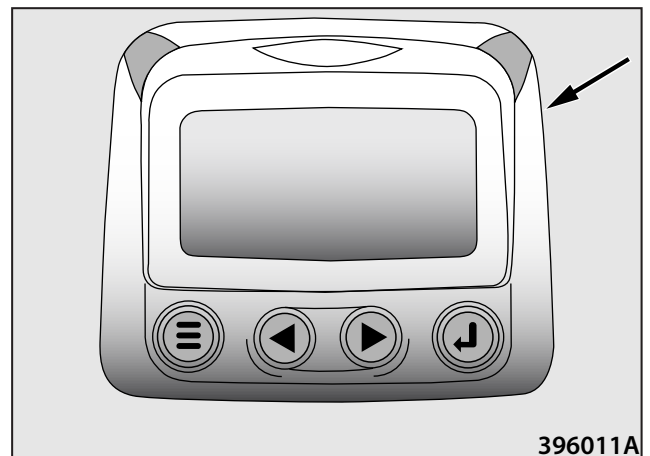

396011A

## 2.6. Actuators and dashboard instruments



### Hydraulic oil thermometer 10

It indicates hydraulic oil temperature during operation. Highest admissible temperature is 90 °C (194 °F) for oil of viscosity class of HV 68 and HV 100. Optimal operating temperature is 50 - 60 °C (122 - 140 °F).

#### The use of oil of other viscosity

Oil viscosity	Max admissible oil temperature
HV 46	80 °C (176 °F)
HV 32	70 °C (158 °F)

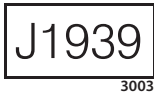

### Socket 11

Connection to ECM (Electronic Actuator Module) - actuator units of the engine and diagnosing of defects or parameter adjustments

#### Note

ECM is designed to process data about engine function, and to actuator its operation.

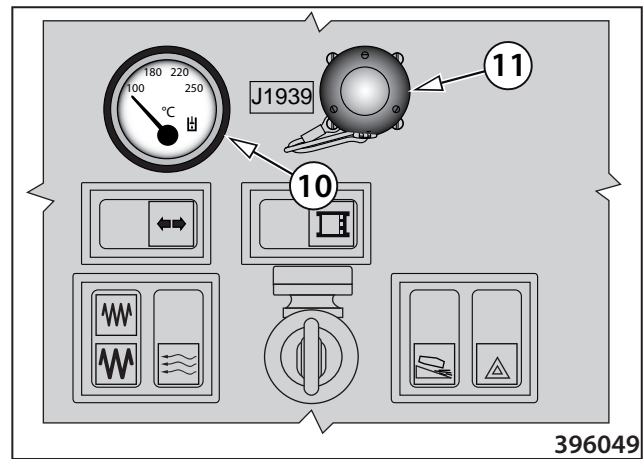

## SWITCHES 12



596473

### Additional lights



596303

### Fender lights + working headlamps - 3-position one

- switched OFF
- 1. Front fender lights ON + rear lights ON, dashboard instrument lighting
- 2. Front lamps ON



591668R

### Rear lights



2246

### Loud horn



AMN40

### Incrementing of engine idling

Idle rmp can be adjusted from 800÷1000 min<sup>-1</sup>.



3006

### Engine idling

It must be switched ON when starting the engine.

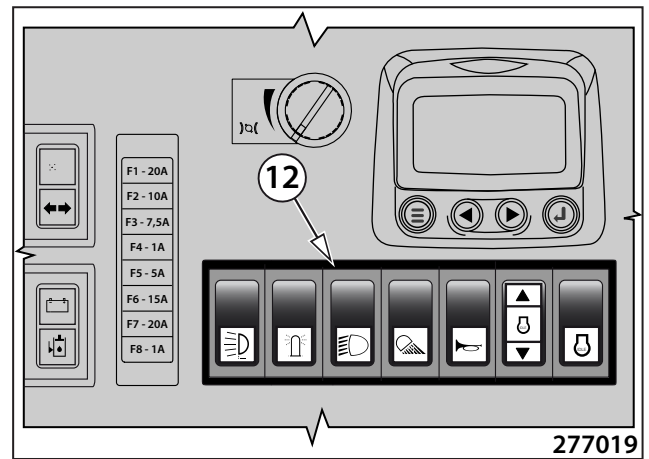

**Flashing beacon** - connect to the socket.



## 2.6. Actuators and dashboard instruments



**Warning lights**



**Limitation for drum slip**

It is used only for Roller to move onto the loading area of a transport vehicle.

**Note**

If the Roller is equipped with the drum slip limitation system then ATC will not be used.

**! CAUTION !**

**Transport speed controller must be switched OFF when drum slip limitation is enabled. At the same time the vibration is interlocked.**



**Inter-axle differential ATC** - Ammann Traction Control - OPTION

When turned on, it is activated in both speed modes (working and transporting).

**Note**

If the roller is equipped with the ATC system (inter-axle differential lock), the drum slip blocking is not used.



**Vibration preselector - 2 positions**

High frequency - low amplitude

Low frequency - high amplitude

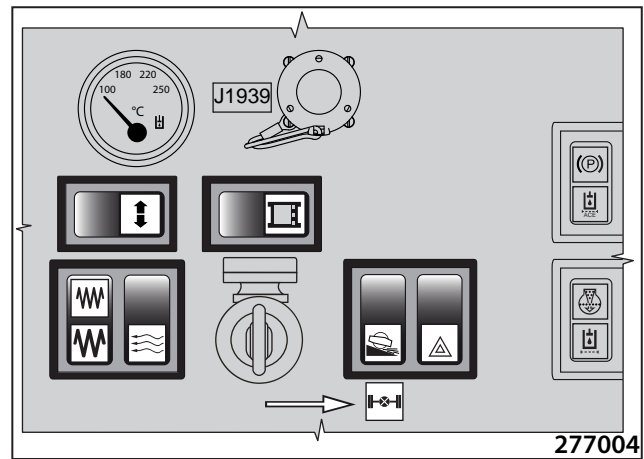



Heater fan switch - 3-position one

2487

- OFF
- high fan motor rpm
- low fan motor rpm

**! CAUTION !**

The fan will provide for air circulation inside cab only.



Change-over switch for direction indicator lights

2489



Compaction meter switch

AMN39

**Note**

Compaction Meter Operation Manual has been supplied separately.

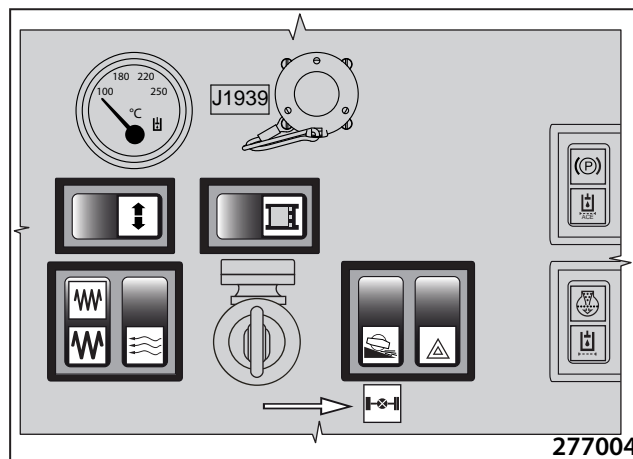

## 2.6. Actuators and dashboard instruments

### PILOT LAMPS 13



**Brake** - pilot lamp ON, signals the Machine is braked.



**Hydraulic oil filter fouled - ACE drum**

It signals filter element is clogged with dirt.



**Promptly replace the filter element!**



**Vibration** - signals the vibration is ON via switch 7



**Direction lights**

**! CAUTION !**

**Rapid flashing signals a failure (defective bulb).  
Check function of direction lights.**



**Zero position of travel actuator - neutral (idle)**

**! CAUTION !**

**Check travel actuator in neutral before starting the engine!**



**ROPS2D (Roll Over Preventative System)**

Flickering indicator lamp incl. acoustic alarm will signal any hazardous bank of the Machine during cross travel of Roller on the slope, and vibration will stop simultaneously – lateral slip hazard.

**! CAUTION !**

**Vibration is unable to switch ON until Machine returns to its safe bank.**

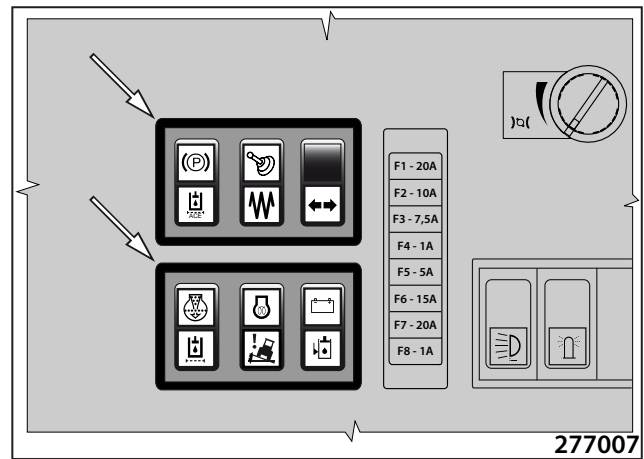



**Engine glowing**

It signals glowing before engine start at low ambient temperature.



**Hydraulic oil filter fouled**

It signals filter element is clogged.



**Hydraulic oil level**

Hydraulic oil level indicator lamp ON will signal the level in the tank has dropped below set limit. Roller will stop - engine stalling.



**Air filter fouled**

It signals filter elements are fouled.

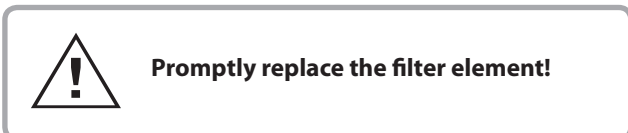

**Recharging indicator lamp**

Goes off when started.

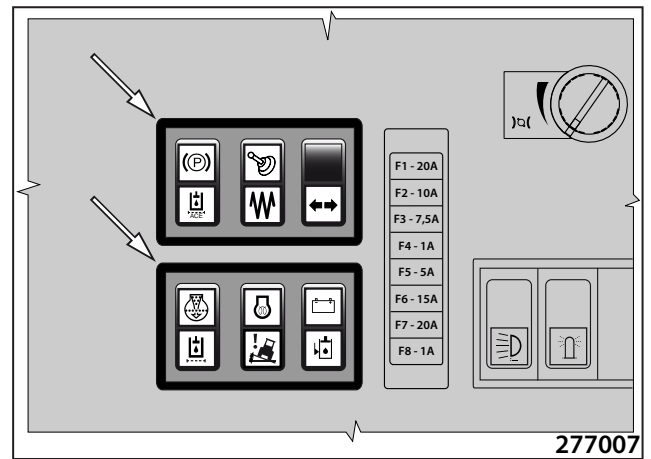

## 2.6. Actuators and dashboard instruments

### Fuse block 14

- Fuse (F1) - 20 A (upper fuse) front + rear lamps, front fender lights + rear lights, auxiliary headlamps, dashboard instrument illumination, bonnet lifting - lowering and Driver's control stand,
- Fuse (F2) - 10 A cab light, loud horn, direction indicator lights, beacon.
- Fuse (F3) - 7,5 A brake, engine STOP, travel, vibration, brake lights, return horn, hydraulic oil level indicator lamp, vibration contact indicator lamp, brake indicator lamp, indicator lamp for zero position of travel actuator
- Fuse (F4) - 1 A POWER VIEW, J1939 socket power supply
- Fuse (F5) - 5 A hydraulic oil thermometer, indicator lamp for vacuum in engine suction filter, regarding indicator lamp, indicator lamp for hydraulic oil filter fouled, glowing indicator lamp, engine rpm switches
- Fuse (F6) - 15 A ventilation and heater fan, front wiper and rear wiper, front washer and rear washer
- Fuse (F7) - 20 A reserve (air conditioner / ROPS2D)
- Fuse (F8) reserve

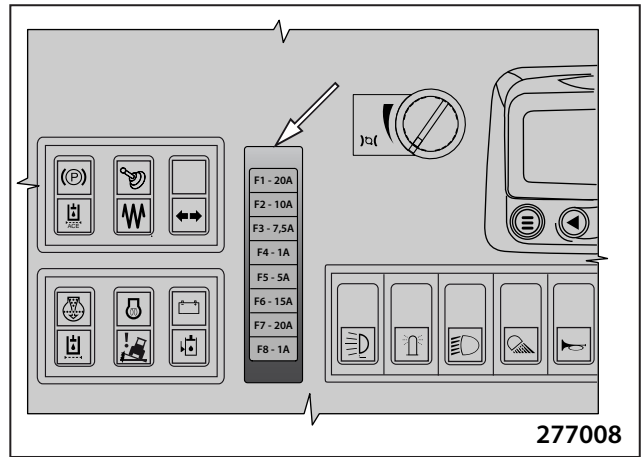

- Fuse (F9) - 50 A
- Electrohydraulic unit (aggregate) for bonnet lifting/lowering and Driver's control stand.



### Engine fuses

- Fuses (F10) - 125 A engine glowing
- Fuse (F11) - 30 A engine electronics
- Fuse (F12) car radio

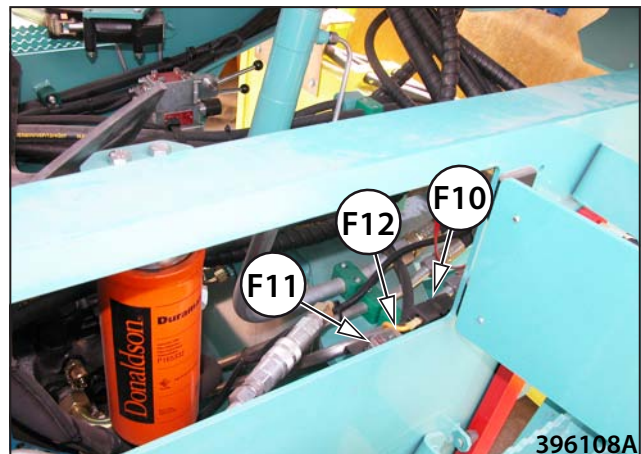

**! CAUTION !**  
**Replace fuses only with fuses of identical value!!!**

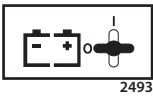

Master switch

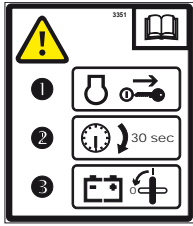

3351

When driving is ended, please use master switch to disconnect battery!

Cut OFF master switch only after 30 sec. following ignition key removed from switch box.

Time limits must be observed for ECM engine data to be stored.

When washing the Machine ALWAYS cut OFF master switch!



## 2.6. Actuators and dashboard instruments

### 2.6.1. Power View control

- 1 Display
- 2 Red LED lights – **ENGINE SHUTOFF** – engine substantial defect alarm
- 3 Yellow LED lights - **WARNING** – engine failure alarm, or minimal fuel level in tank alarm
- 4 Menu selection pushbutton – to enter or exit menu
- 5 Pushbutton – to move cursor UP – illuminates data on display or moves parameter option to the left or up
- 6 Pushbutton – to move cursor DOWN – illuminates data on display or moves parameter option to the right or down
- 7 ENTER pushbutton – selects menu or parameter, or conceals/displays active error code

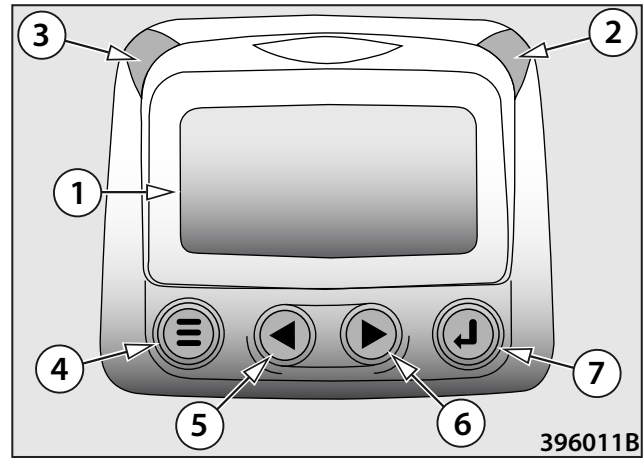

**Red LED lights – reduce engine power, stop the machine immediately at safe place and shut off the engine! Call Cummins service centre to repair the defect. Do NOT operate the machine unless the defect has been repaired!**



**Yellow LED lights - warning – engine failure alarm, or minimal fuel level in tank alarm. Reduce engine power, stop the machine immediately at safe place and shut off the engine! Repair the defect or call Cummins service centre. Do NOT operate the machine unless the defect has been repaired!**

#### **! CAUTION !**

**When Power View Murphy display shows code and engine failure outline, contact the regional representative of Cummins engines and report the failure code. List of representatives and contact data are given in the Engine Operation Manual supplied with the machine.**

### NAVIGATION BASIS

Menus have pages with other items. Use CURSOR (ARROWS) to select some of the items highlighted.

Operate pushbuttons with light touch.

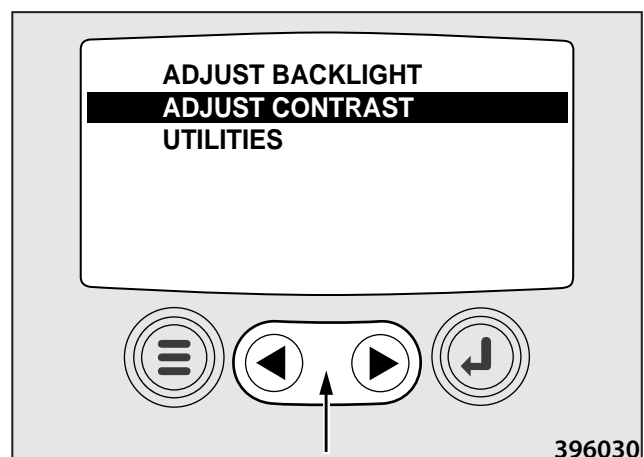

Use ENTER 1 to open highlighted item. Press buttons in Menu 2.

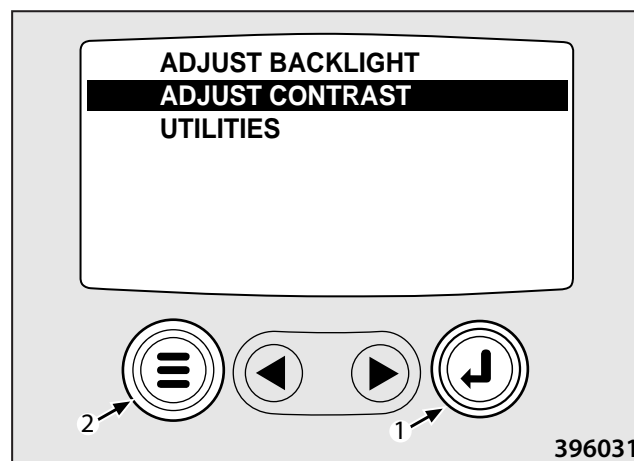

Main menu will be displayed (GO TO 4-UP DISPLAY).

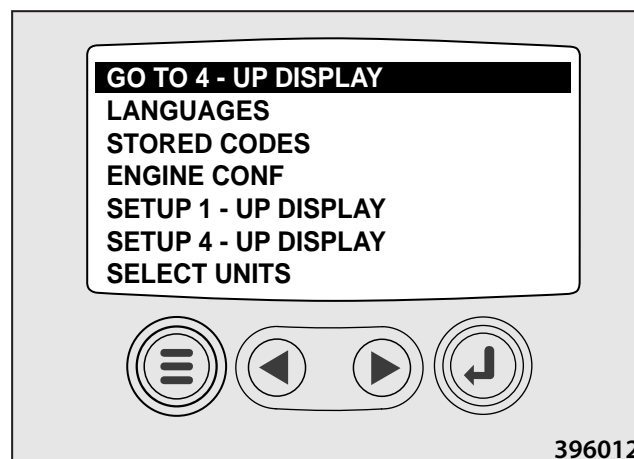

Press ENTER button.

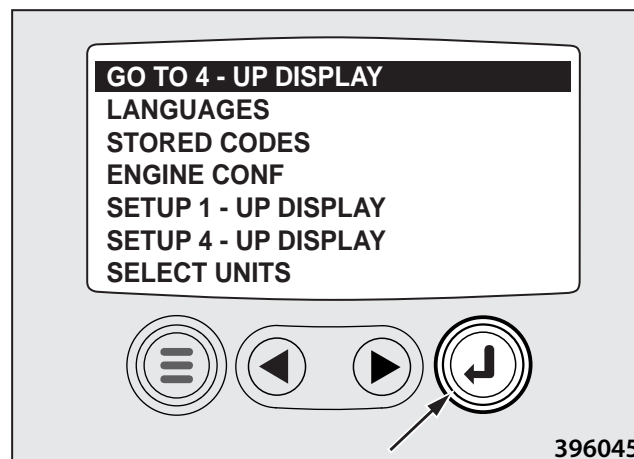

Four-parameter display will show. Press MENU button to display main menu.

**Note**

Four-parameter display is basic setting from the machine manufacturer; turn ON ignition box key to display it.

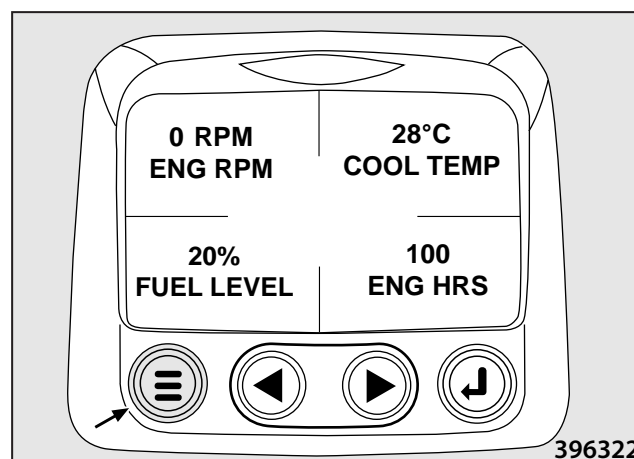

## 2.6. Actuators and dashboard instruments

Press ENTER button to move to GO TO 1 - UP DISPLAY menu where parameters are displayed one by one.

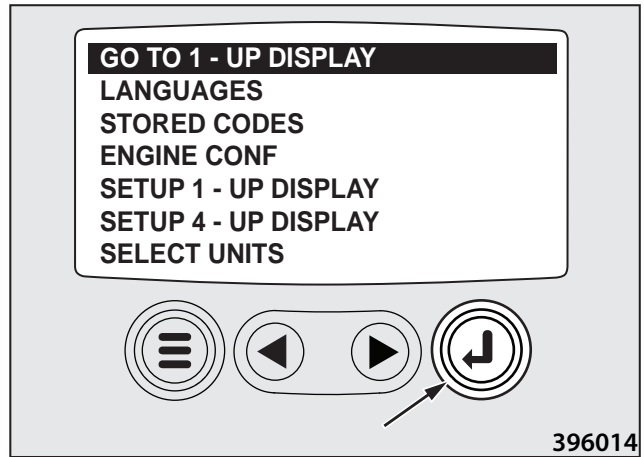

Use cursor 1 to display step by step eight parameters set (Number of engine operating hours, engine rpm, el. system voltage, engine load in % during actual engine speed, cooling liquid temperature, engine oil pressure, fuel level, instantaneous consumption). Press MENU 2 button.

### Note

If the engine is at rest, the battery voltage is indicated. If the engine is running, then roller's el. system voltage is indicated.

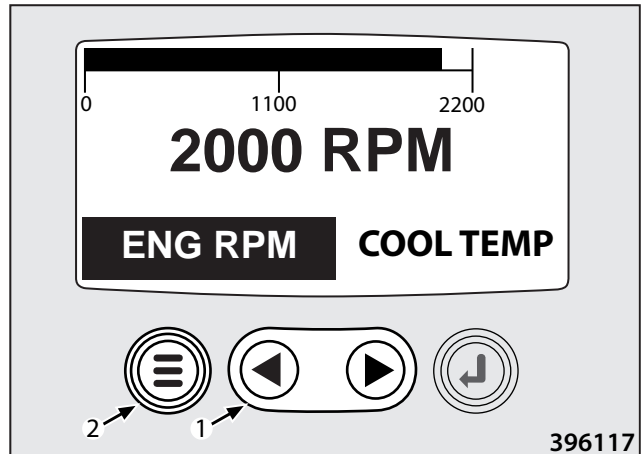

Main menu is displayed again. Press ENTER button to move back to four-parameter display.

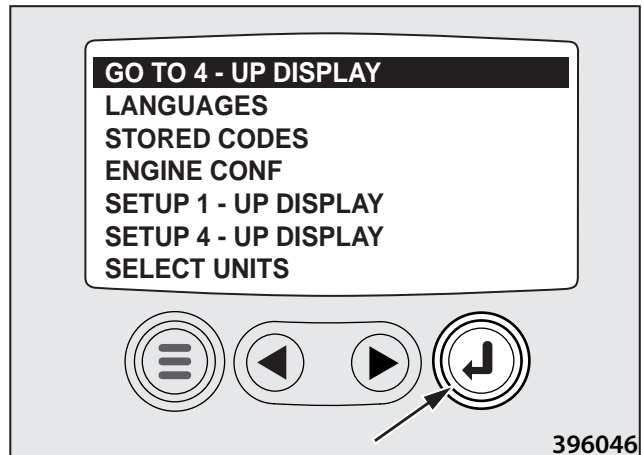

Use cursor in main menu to move to next item, i.e. LANGUAGES – to select language.

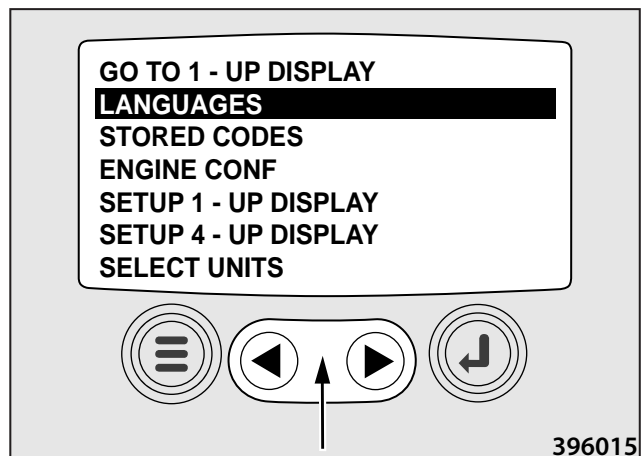

First, press ENTER to select language.

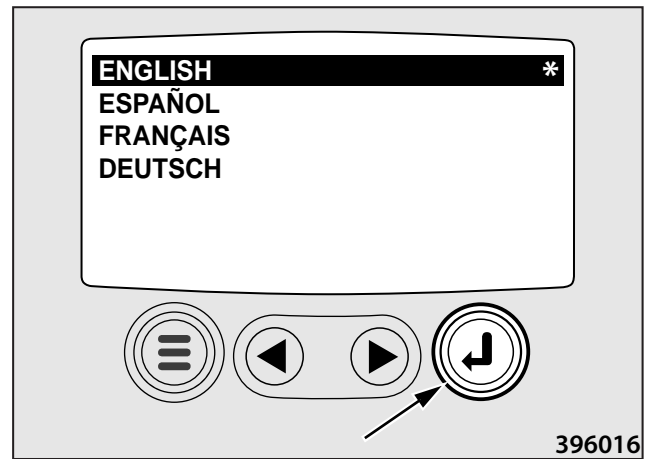

Another time, use cursor to select language.

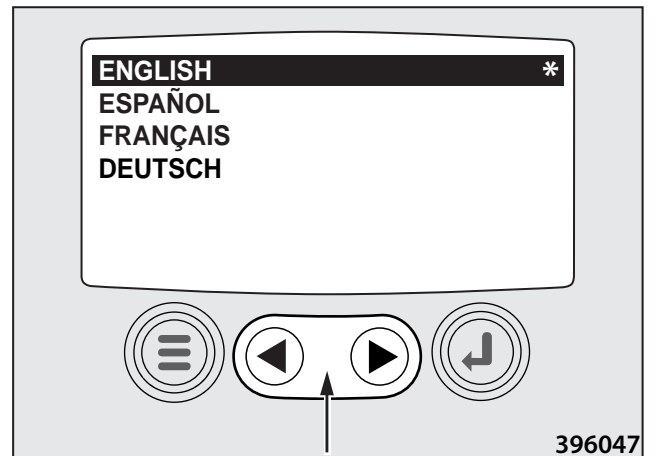

Press ENTER to confirm.

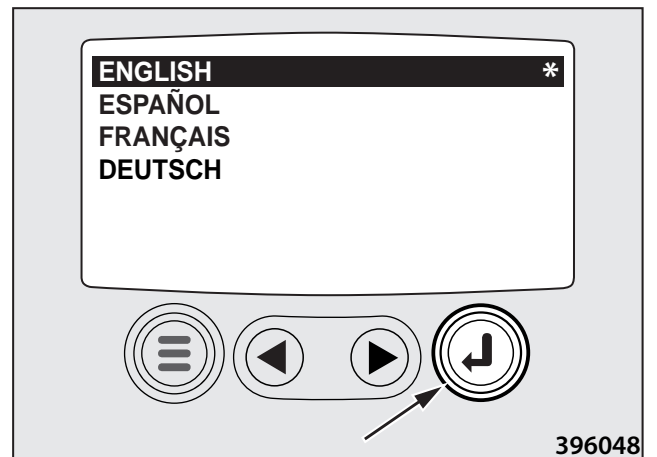

Press MENU to return to the menu.

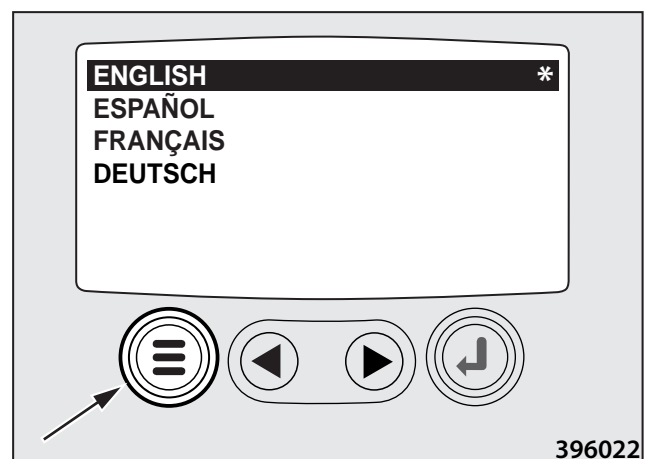

## 2.6. Actuators and dashboard instruments

STORED CODES - stored defects not enabled. Move cursor in main menu to the item.

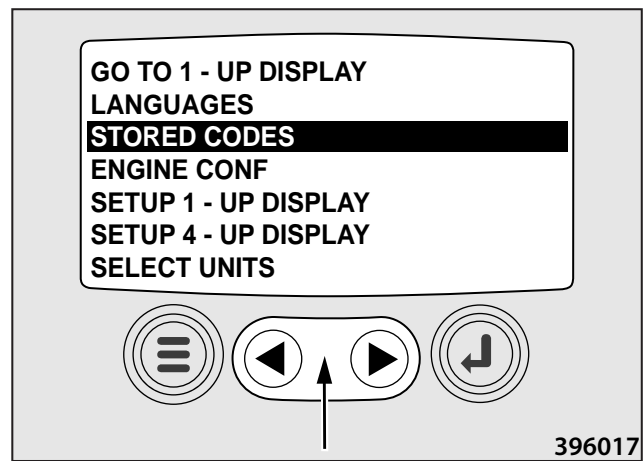

Continue with ENTER to display stored failures.

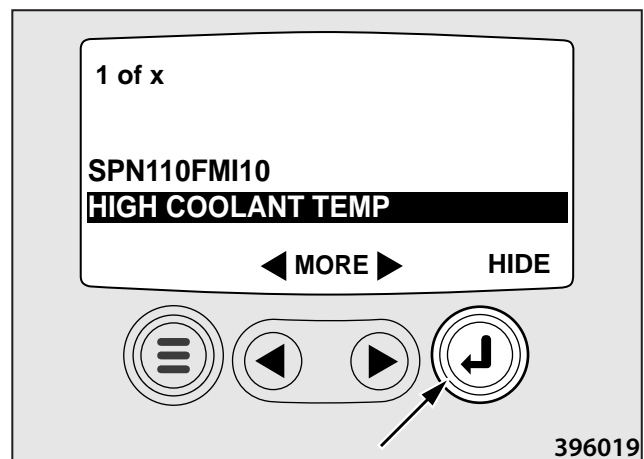

When the word MORE occurs use cursor to move to other stored failures.

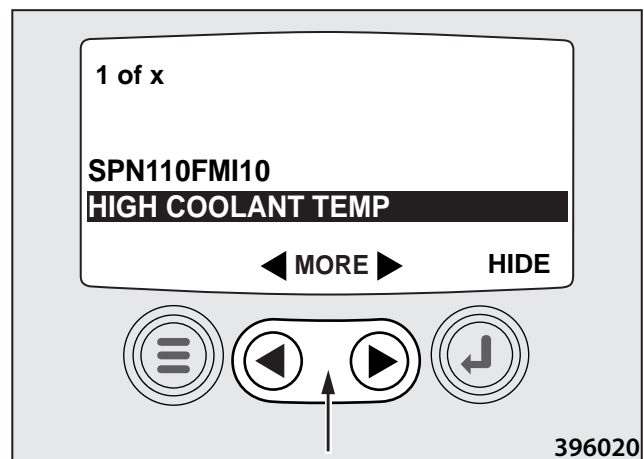

Press Menu to return to main menu.

ENGINE CONF - menu to scan engine parameters, refer to CAUTION.

SETUP 1 - UP DISPLAY – press Enter to have various modifications of parameter display available.

CUSTOM SETUP – possible to select from displayed number of parameters, and to set the sequence in which parameters will be displayed (Number of engine operating hours, engine rpm, wiring voltage, battery voltage, engine load during actual engine speed in %, cooling liquid temperature, oil pressure, etc.). The following parameters have been set by the machine manufacturer.

- 1) ENG RPM
- 2) COOL TEMP
- 3) BAR OIL PRES
- 4) % LOAD@ RPM
- 5) VDC SYS VOLT
- 6) ENG HRS
- 7) FUEL LEVEL
- 8) FUEL RATE

AUTOMATIC SCANNER – set parameters are displayed automatically one by one in time interval.

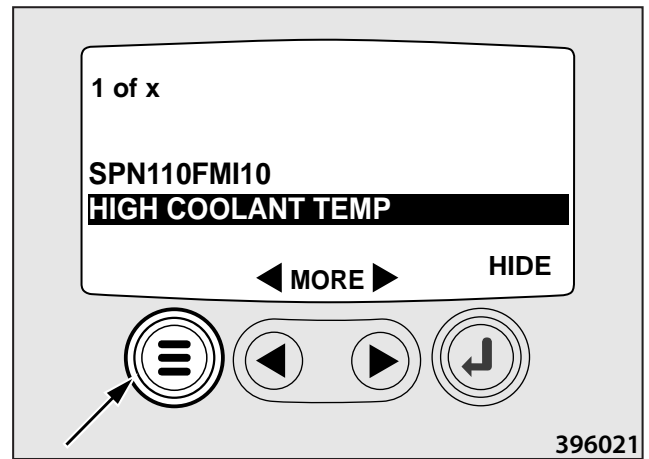

**! CAUTION !**

**Roller manufacturer does not permit to alter the set parameters in CUSTOM SETUP. Parameters set up are the most appropriate optimum of set engine function check.**

In main menu, with cursor to SELECT UNITS - selection of measurement unit for parameters displayed.

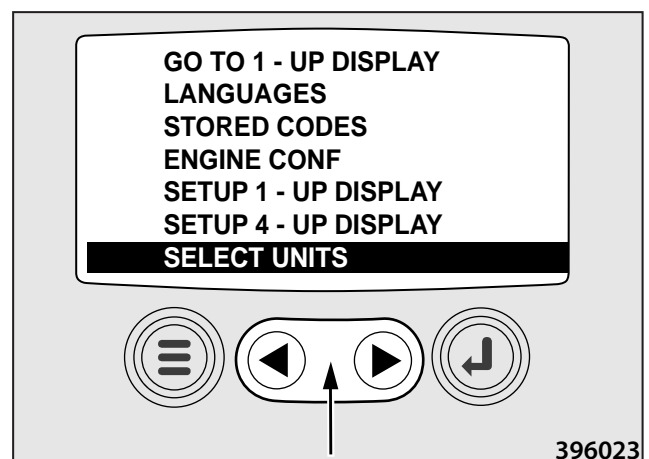

## 2.6. Actuators and dashboard instruments

Press ENTER to open units menu:

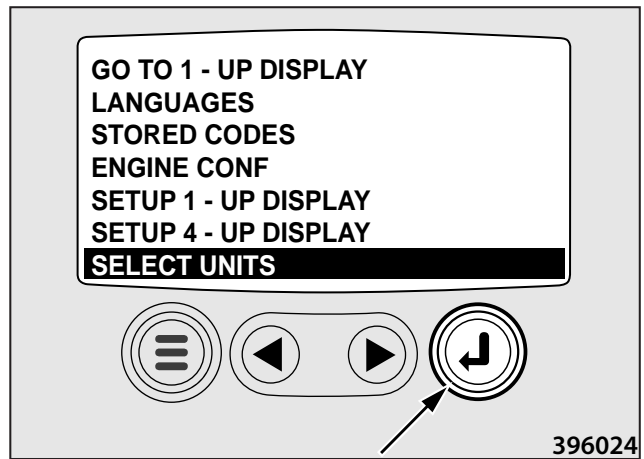

Use cursor to set 1 ENGLISH and the indicated variables will be displayed in PSI units (pressure), °F (temperature).

When METRIC KPA or METRIC BAR are set the variables displayed are in IS units, i.e. kPa, bar, °C, press Enter 2 to confirm selected variables. Press MENU 3 to return to main menu.

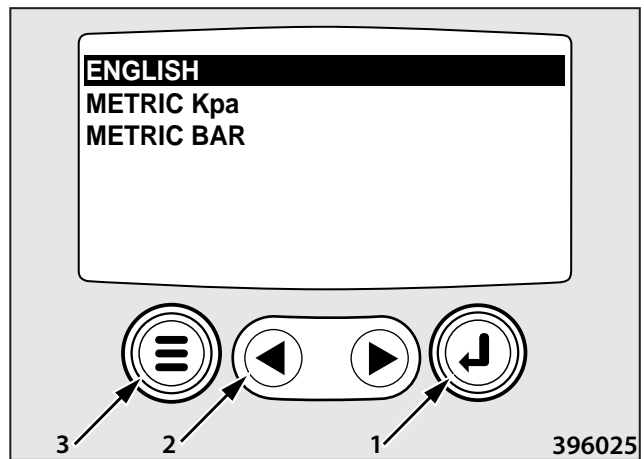

In main menu, move cursor to ADJUST BACKLIGHT - to adjust intensity of display backlight.

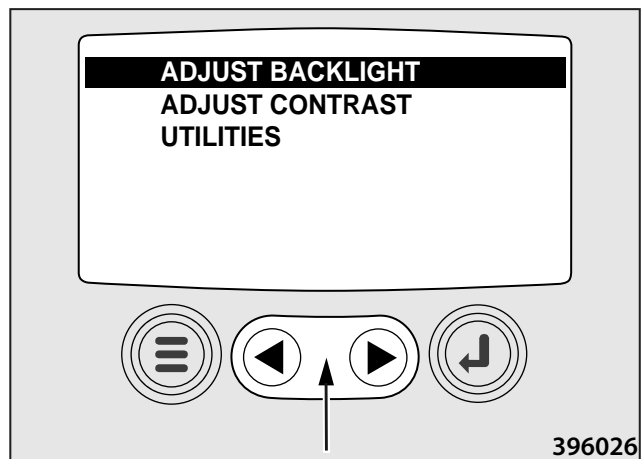

Press ENTER to open the item

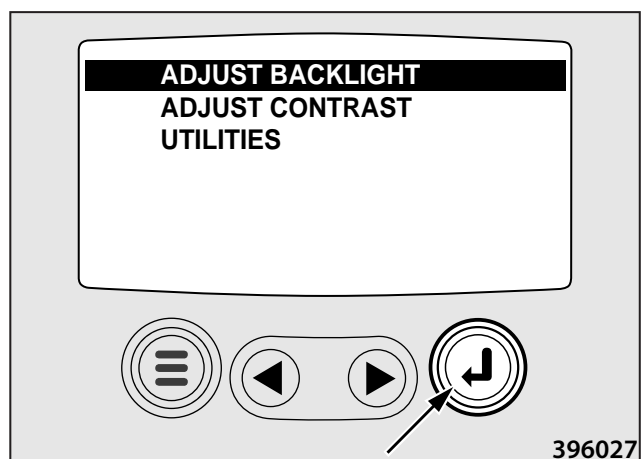

Use CURSOR to adjust backlight intensity

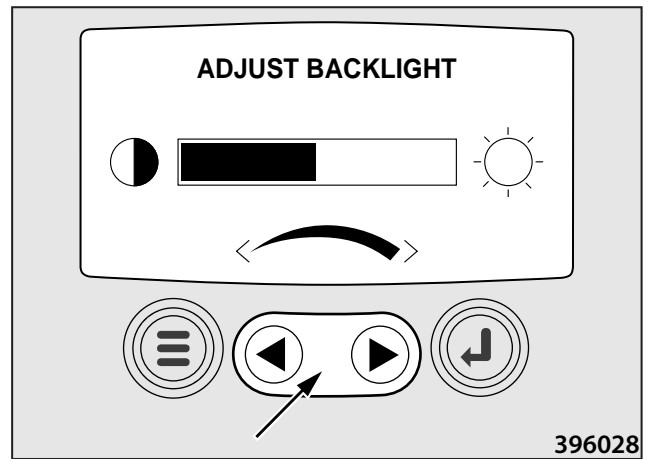

Press MENU to return to main menu

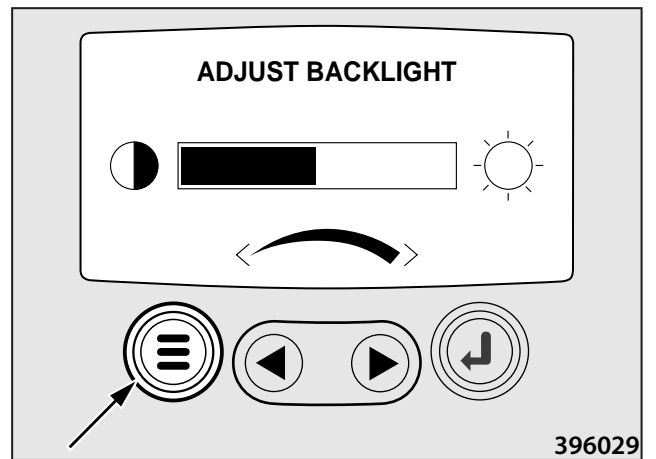

In main menu, move cursor to ADJUST CONTRAST - to adjust contrast.

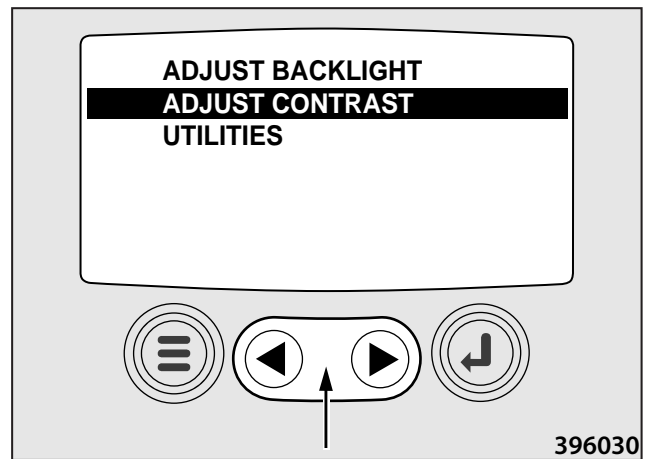

Press ENTER to open the item

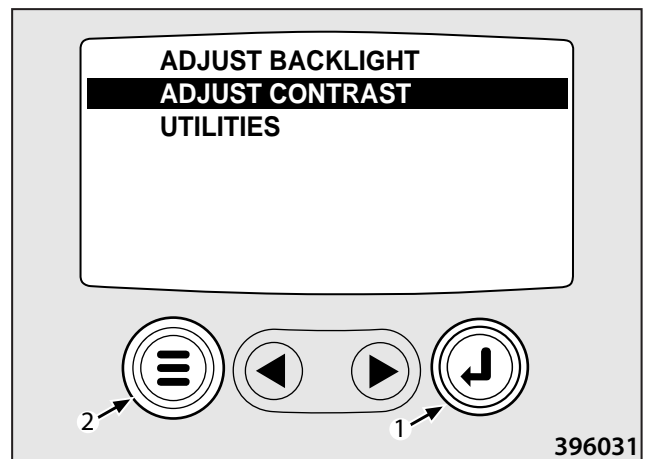

## 2.6. Actuators and dashboard instruments

Press CURSOR to adjust contrast

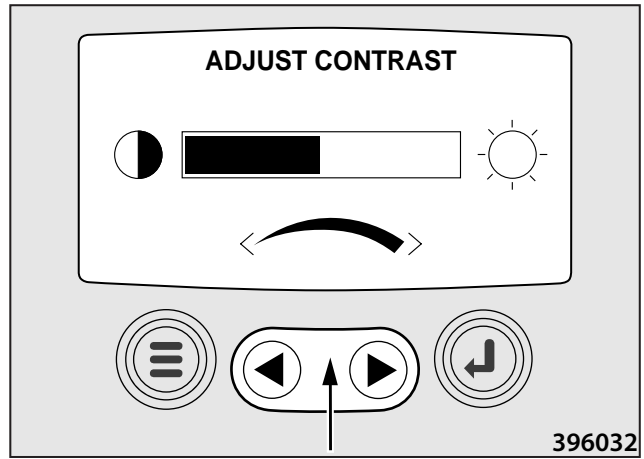

Press MENU to return to main menu

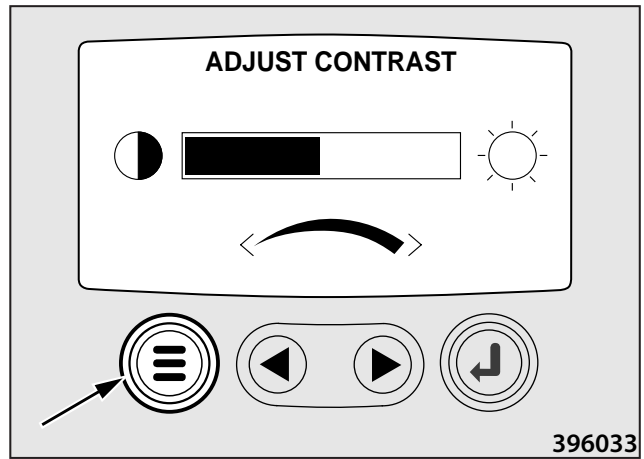

### ENGINE FAULT SIGNALLING

#### ALARM SIGNALLING

Alarm signal, indicated with yellow LED ON, informs about engine malfunction - **Warning**.



**Engine failure alarm, or min fuel level in tank alarm. Reduce engine power, stop the machine immediately at safe place and shut off the engine! Repair the defect or call Cummins service centre. Do NOT operate the machine unless the defect has been repaired!**

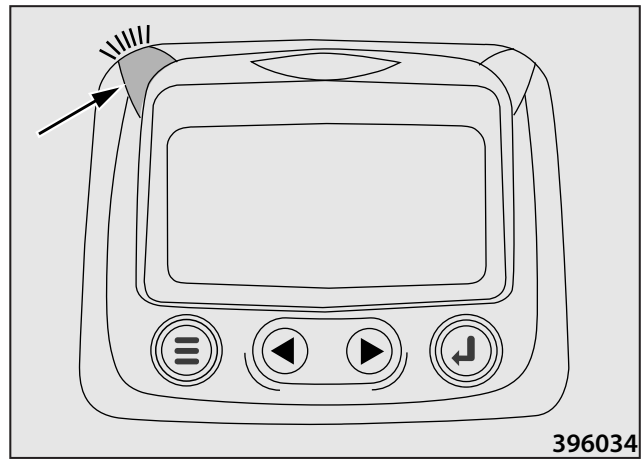

Engine failure registered from engine ECU (Electronic Actuator Unit) will be displayed via error code for a failure and description on the display.

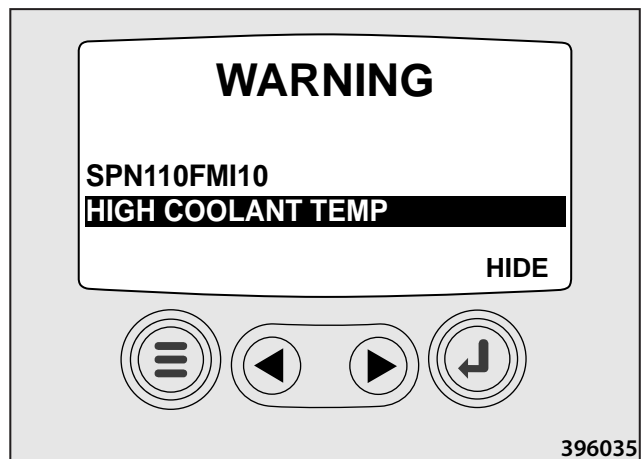

Upon registration of more errors, please use the cursor to display the registered failures step by step.

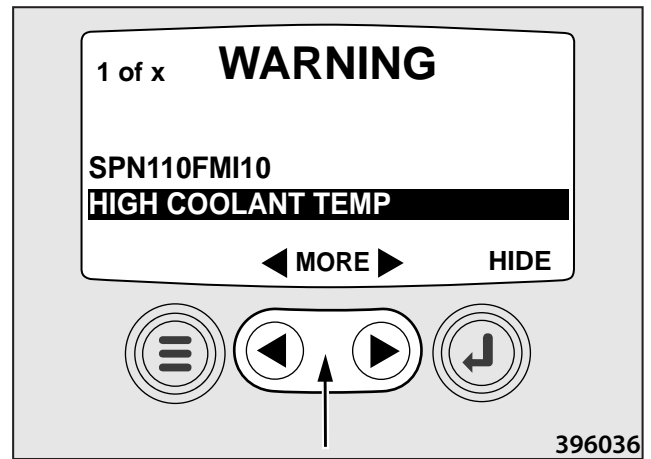

Press ENTER to acknowledge and hide the display.

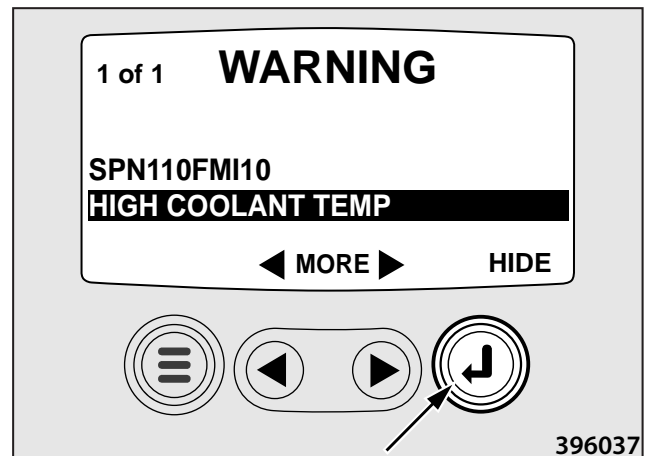

Return to display 1 of parameter display with warning icon for active failure in RH corner

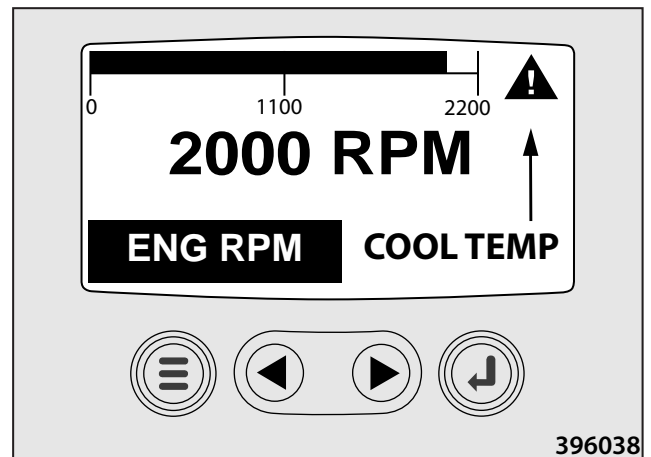

or display 4 of parameter display with warning icon for active failure in the centre.

**Note**

Press ENTER to display again the hidden error code for failures. Press ENTER again to display either with 1 parameter or 4 parameter. Until defect is eliminated the displaying of warning icon will remain active.

**! CAUTION!** When failure outline and failure code are indicated on instrument board display, contact the regional representative of Cummins engines, unless the failure is possible to repair. Contact data are given in the Engine Operation Manual supplied with the machine.

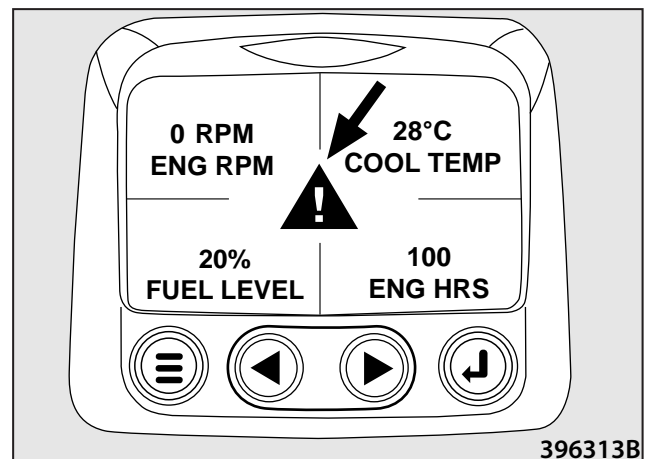

## 2.6. Actuators and dashboard instruments

### ENGINE CUT OFF ALARM

Alarm signal indicated by red LED ON informs about engine's substantial defect – **Shut off engine**.



**Reduce engine power, stop the machine immediately at safe place and shut off the engine! Call Cummins service centre to repair the defect. Do NOT operate the machine, unless the defect has been repaired!**

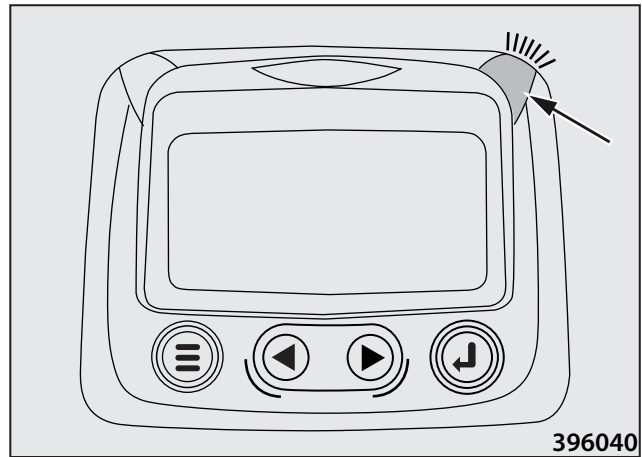

Engine failure registered from engine ECU (Electronic Actuator Unit) will be displayed via error code for a failure and description on the display warning to "SHUT DOWN".

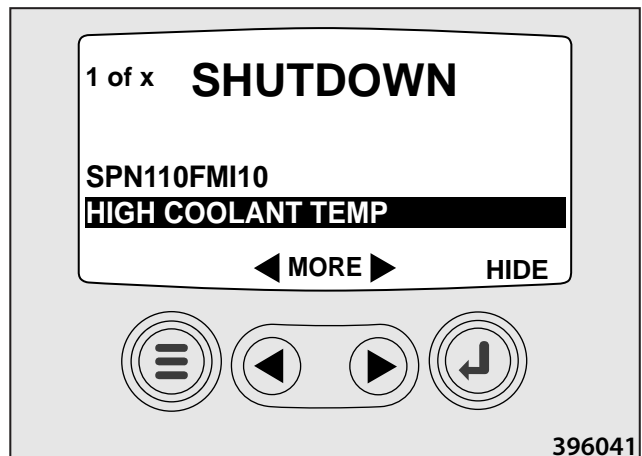

Press ENTER to acknowledge and hide the display.



Return to display 1 of parameter display with "SHUT DOWN" warning icon in RH corner.

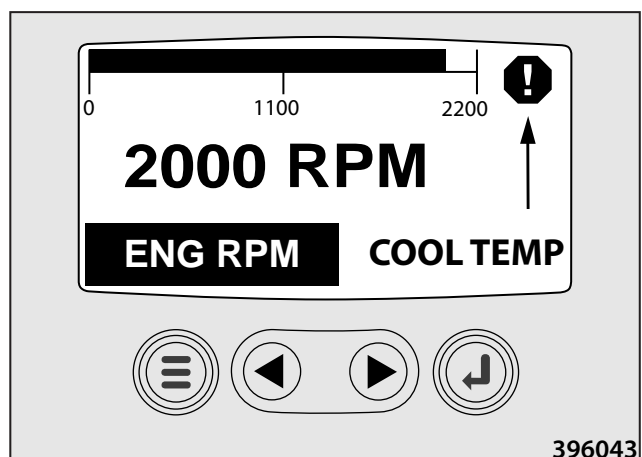

Or of 4 parameter display with warning icon for active failure in the centre.

**Note**

Press ENTER to display again the hidden error code for failure. Press ENTER again to display again either with 1 parameter or 4 parameters. Until defect is eliminated the displaying of warning icon will remain active.

**! CAUTION !**

**When failure outline and failure code are indicated on instrument board display, contact the regional representative of Cummins engines, whose contact data are given in the Engine Operation Manual supplied with the machine.**

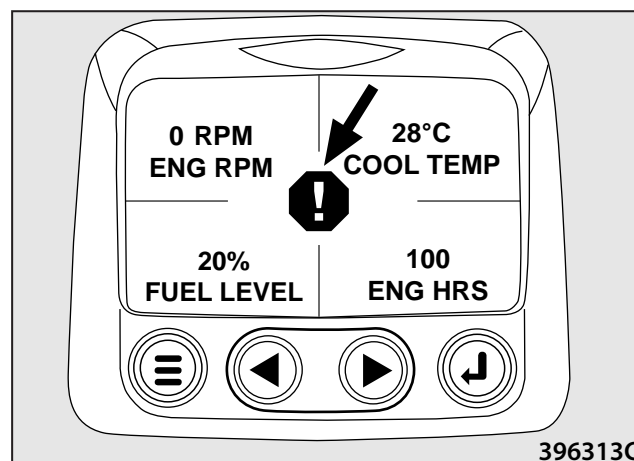

## 2.6. Actuators and dashboard instruments

ERROR MESSAGES	
Error message	Signature
" <b>WAIT TO START PREHEATING</b> " is displayed	The ECU is broadcasting a 'Wait To Start' message. Engine manufacturers typically recommend against starting the engine while the ECU is broadcasting this message. Once the ECU stops broadcasting this message, this screen will no longer be displayed on the Power View.
" <b>CANBUS FAILURE</b> " is displayed	The Power View has not received any valid J1939 CAN messages for at least 30 seconds.
" <b>TIMEOUT ECU NOT RESPONDING</b> " is displayed	The Power View sent a request to the ECU for Stored Fault Code (DM2) information, and the ECU did not respond to the request. This message on the PowerView indicates the ECU may not support Stored Fault Code (DM2) functionality over J1939.
" <b>NO STORED CODES</b> " is displayed	The Power View sent a request to the ECU for Stored Fault Code (DM2) information, and the ECU responded. There are zero stored codes.
" <b>NO GAGE DATA</b> " is displayed	The Power View has no record of gages connected to the RS485 bus.
" <b>NO DATA</b> " is displayed in place of a parameter value	The Power View has not received data for the selected parameter for at least 5 seconds.
" <b>NOT SUPPORTED</b> " is displayed in place of a parameter value	The ECU is sending a message that it does not support this parameter.
" <b>DATA ERROR</b> " is displayed in place of a parameter value	The ECU is sending a message that there is a data error with this parameter. Or (PV101 only) FUEL LEVEL has been selected for display, ANALOG INPUT has been set to FUEL LEVEL, but no Murphy Fuel Sender has been connected to the analog input.
One of the 4-UP quadrants is empty	No parameter has been selected for display in this quadrant.
Display is not readable, either very dim or very dark	The LCD contrast may have been over or under adjusted. Press and hold the MENU key for approximately 5 seconds. This will reset the LCD contrast setting to factory default.

## 2.7. Machine control and use

### 2.7.1. Starting the engine



**Before starting the engine, please confirm nobody gets endangered when engine is started!**

#### How to start:

- Pump fuel via feed hand pump on the engine (upon long term shutdown of the Machine).
- Cut in battery disconnecter.

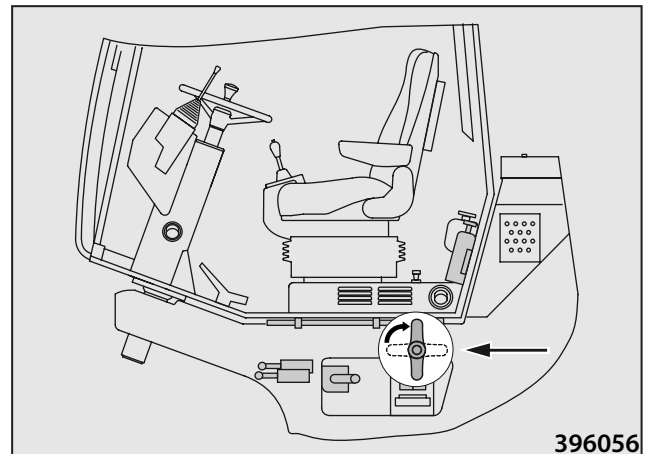

- Check "TOTAL STOP" 6 is off, and brake 5 is on, and actuator 2 in neutral.

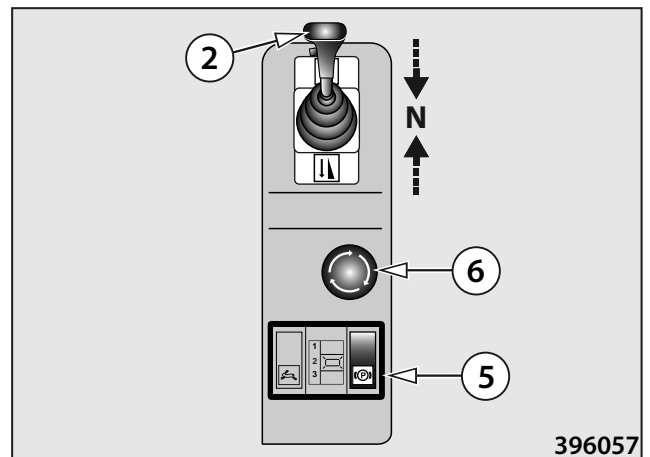

- Turn on IDLE 1 engine idling switch.

#### Note

Use switch 2 for stepping of idling at IDLE switched on to select idle rpm from 800 ÷ 1000 min<sup>-1</sup> with engine heated to 30 °C (86 °F). Newly selected rpm will be stored in engine ECM memory and remain set for next engine starting.



**It is recommended not to alter RPM of 850 min<sup>-1</sup> set by Manufacturer since Roller's parameters have been adjusted to this RPM.**

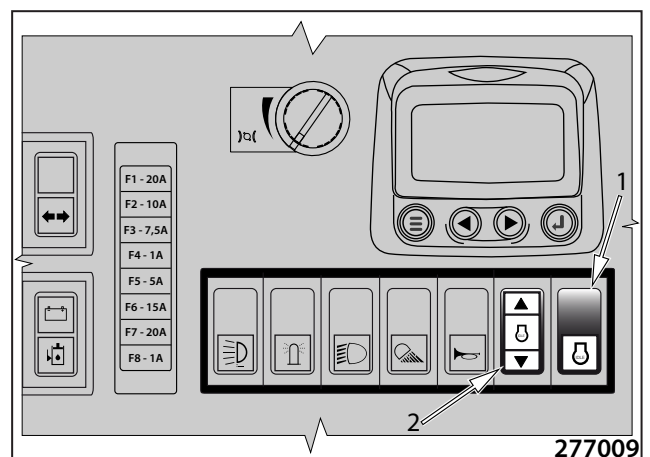

## 2.7. Machine control and use

- Turn key in ignition box 1 to position "I" - the pilot lamps for brake, recharging, neutral, engine glowing (as per ambient temperature) will light. ROPS2D indicator lamp will light up shortly along with acoustic alarm.

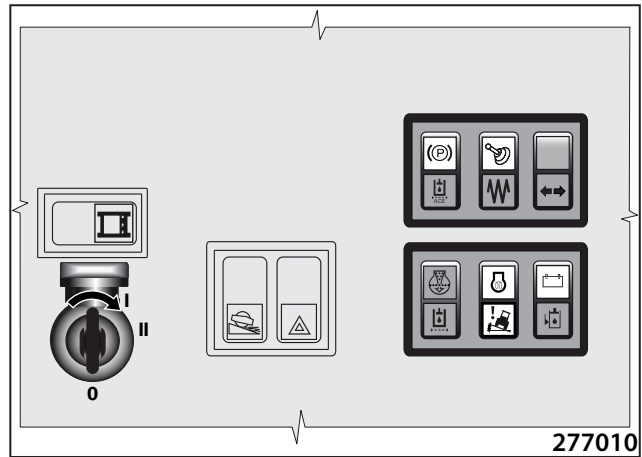

- The display will show logo and then 4 quadrants with parameters set.

### Note

The display has been set by Manufacturer, it is possible to change it to a single parameter display, refer to par. 2.6.1.

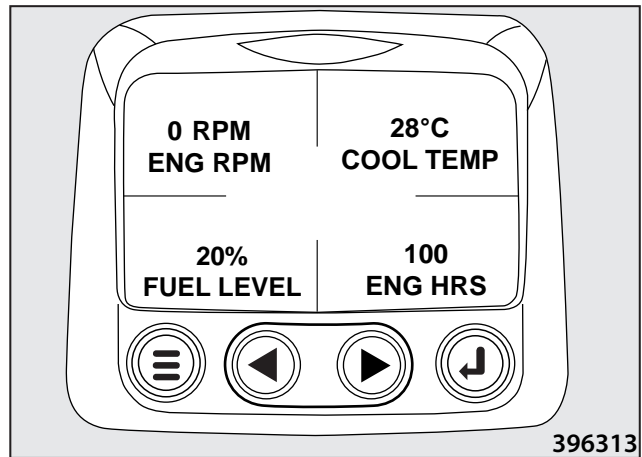

- Glowing indicator lamp goes off, please switch to position "II" to start the engine and (hold key in "II" position only until engine is started).



**Do NOT start for no longer than 30 sec. Repeat starting only after 2 minutes.**

**Repeat starting max 3x, then track a failure within fuel system. Absence of smoke in exhaust will signal a defect within fuel supply to the engine.**

**When started, please check recharging function - indicator lamp must go off.**

**Do NOT increase RPM abruptly, let engine run for 3 to 5 minutes in idle speed so to stabilize pressure in the engine, and bearings to lubricate. Do not let engine run idle longer than 10 minutes, engine may get damaged.**

**Starting will be interlocked if:**

**Roller is not braked.**

**Actuator 2 not in neutral.**

**STOP button pressed.**

**Driver not sitting on the seat.**

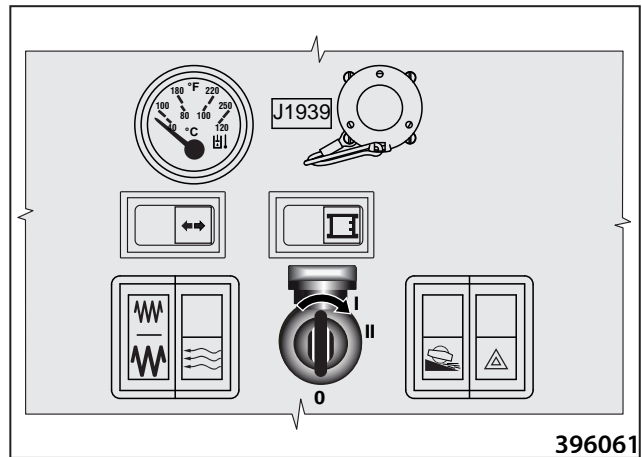

**When using auxiliary starting source this power supply shall have starting voltage of 24 V.**

### How to start via starting cables from different machine

1. Connect one end (+) of cable pole to (+) pole of discharged battery.
2. Connect second end of (+) cable pole to (+) pole of the Machine battery from which starting will be made.
3. Connect one end of (-) pole to (-) pole of vehicle battery with the help of which starting will be made.
4. Connect second end of (-) cable pole to such part of the Machine being started which is wired in the engine (or eventually in the engine block itself).

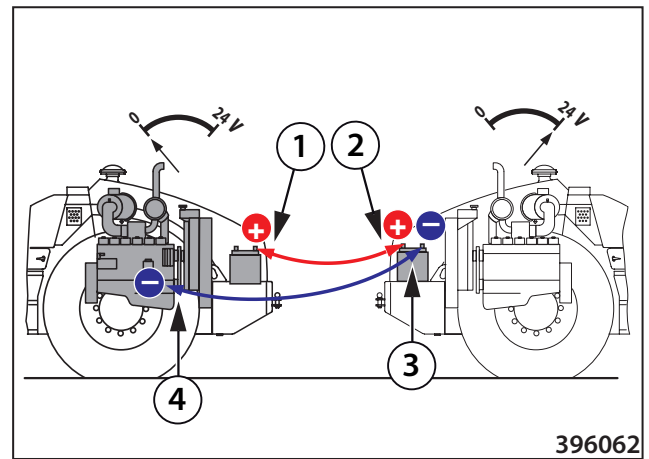

**Observe unconditionally the sequence of operations given below!**

**Once started, disconnect the starting cables in reverse sequence.**

**When having used starting unit with no batteries connected do not disconnect this unit before Machine's battery is connected.**



**Do NOT connect cable of (-) pole to (-) pole of discharged battery of started Machine! Strong sparking followed by explosion of gas generated by the battery may occur when starting.**

**Non-insulated parts of starting cable collets may not touch each other!**

**Starting cable connected to battery (+) pole may not come into contact with electrically conductive parts of the Machine - short-circuit possible.**

**Do NOT bend over the battery - hazard of acid burn!**

**Eliminate presence of flammable sources (open fire, burning cigarettes, etc.).**

**Do NOT check presence of voltage in wires with the use of sparking via Machine frame!**

## 2.7. Machine control and use

### 2.7.2. Travel and reversing



**Give acoustic signal for Machine started to move, and wait long enough so any persons present could leave the area within Machine vicinity (under the Machine) in time!**

**Before starting to move, please confirm the area in front and behind the Machine is free and that no persons are found therewithin!**

- Switch ON vibration amplitude 1, indicator lamp 2 will light.

- Switch OFF IDLE and engine rpm to max. 2200 min<sup>-1</sup> via gas actuator 8.

- Turn OFF speed controller 3 - thus switching ON working speed. Switch preselector 4 to the suitable operating speeds "1" ÷ "3". Brake off the Roller via pressbutton 5. Start moving the Machine and turn ON the vibration via switch 7 - you can stop the vibration by pressing and releasing the pressbutton.

#### Note

You may select gear "1" ÷ "3" of the operating speed via preselector 4 while driving.

#### ! CAUTION !

**When driving uphill, engage gear "3" via preselector 4 so to achieve max tractive (pulling) force (climbability) of the Roller.**

- By switching ON the transport speed 3 you turn OFF operating speed - vibration is interlocked.

#### Note

You may switch ON/OFF transport speed controller 3 while driving.

Unless there is enough tractive force while climbing uphill - please switch OFF the controller and select gear "3" via selector 4.



**Before driving downhill, please turn OFF the transport speed controller!**

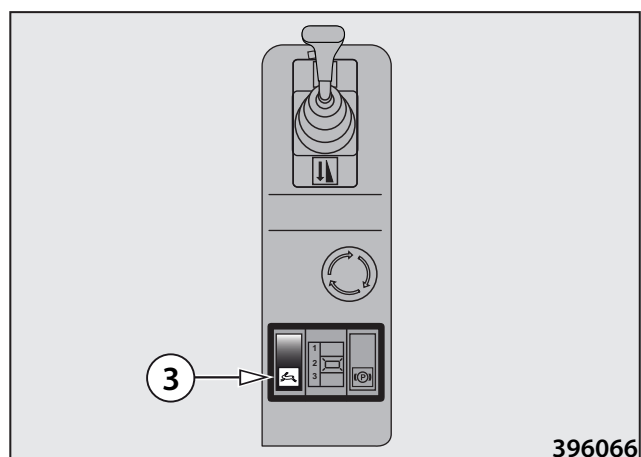
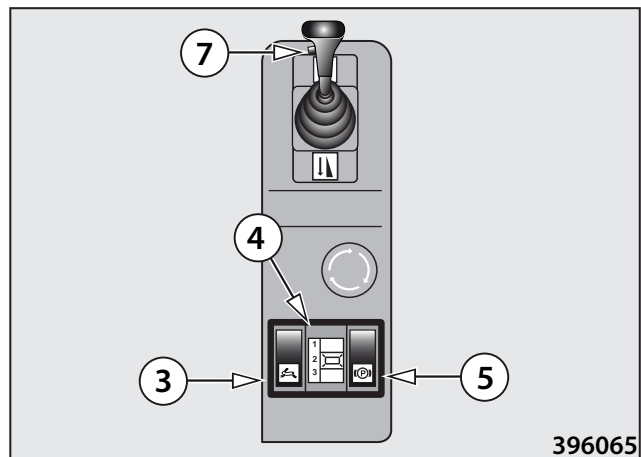
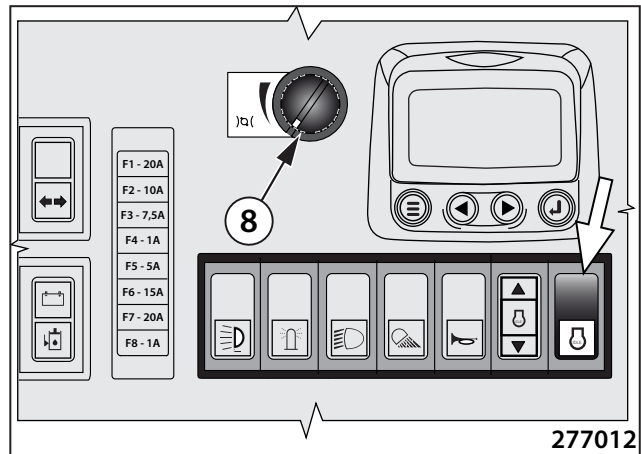
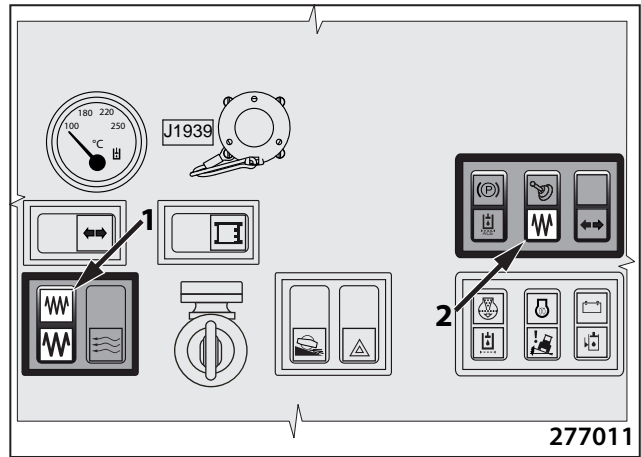



For the maximum permissible slope gradient when driving uphill and across the slope gradient, see figures.

The values given are lower depending on adhesive conditions and the machine instantaneous weight!

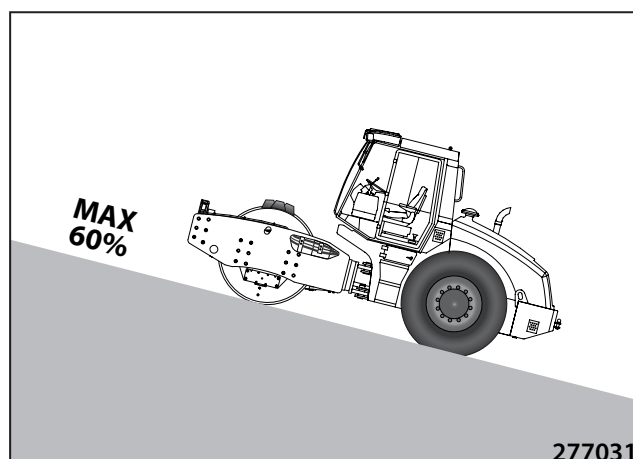
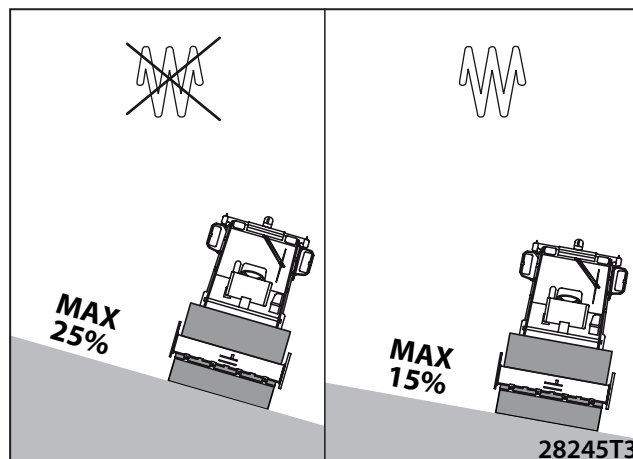

- When driving in a difficult terrain with an impaired adhesion, turn on the ATC function (optional equipment). After leaving the difficult terrain, turn off the function.

**Note**

The function can be activated in both modes – working and transport speeds.

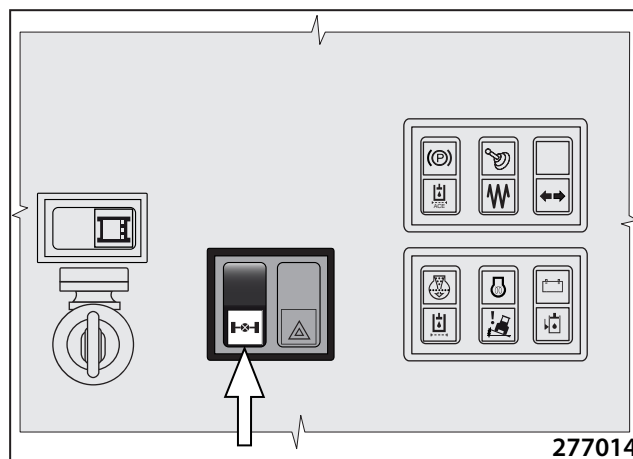

Do NOT load engine at full capacity until it reaches 60 °C (140 °F) temperature.

Do NOT turn OFF the controller at high speed - sudden deceleration (retardation) will occur followed by an impact within hydraulic system. Turn OFF the controller at low speed or with standing Machine!

## 2.7. Machine control and use

### **! CAUTION !**

If Driver stands up from the seat while driving the speed will slow down until Roller is fully stopped and braked, this will last 4 seconds. Following next 4 sec. the engine shuts down.

To start the engine again the Driver must sit down again, shift the travel actuator to neutral, turn ON brake switch, turn ignition key to "0" position and then start the engine. Driver must brake off before starting to move.

If Driver sits down again before 4 sec. have elapsed, then the Roller will continue driving at a speed selected.

If Driver sits down after 4 sec. have elapsed, then the engine will shut down, the Driver may start moving it again. Before that the Driver must shift the controller to neutral, and select again the original driving direction.

### **! CAUTION !**

Indicator lamp will light up and acoustic signal will be heard with Rollers equipped with ROPS2D and driving across a slope with gradient over 12°. Vibration will cut off if Roller bank increases to 15°.

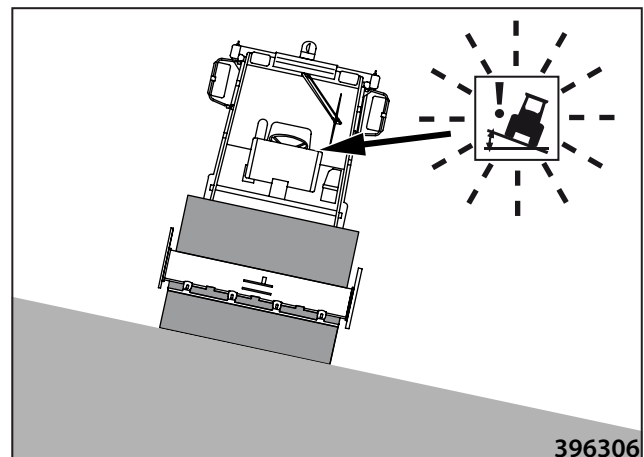

2.7.3. Emergency stop of the Machine

 **Apply in the event when engine is unable to stop via ignition key or when Machine is unable to stop via switching the travel controller to neutral.**

- Press TOTAL STOP (emergency brake) - the engine stops and the Machine stops moving.

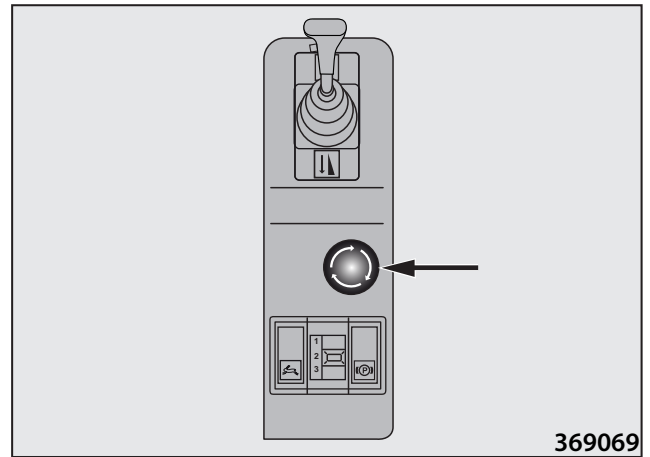

- Before new engine start, please shift controller 2 to "N" position and turn pressbutton 6 according to arrow direction. Brake via parking brake switch 5.

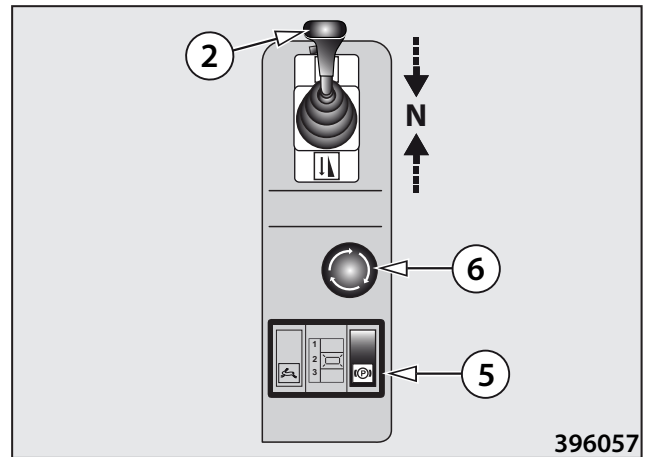

- Switch key 1 to "0" position and then start.

 **Do NOT apply emergency brake during normal operation just to shut off the engine.**

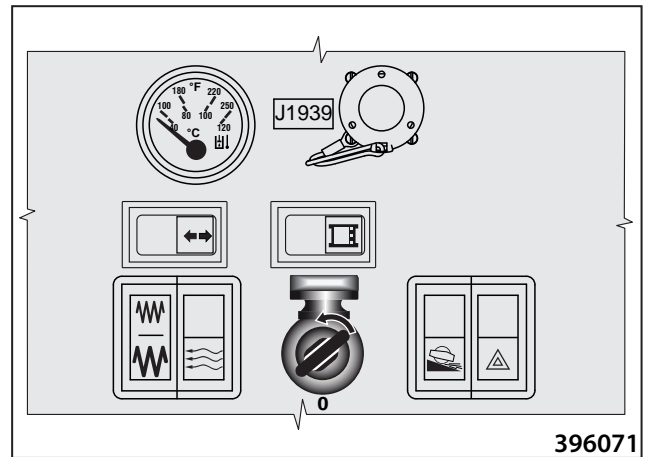

## 2.7. Machine control and use

### 2.7.4. How to stop the Machine and its engine

- Turn OFF the vibration via switch 7, if turned ON. Stop the Machine via actuator 2, and brake with parking brake 5.

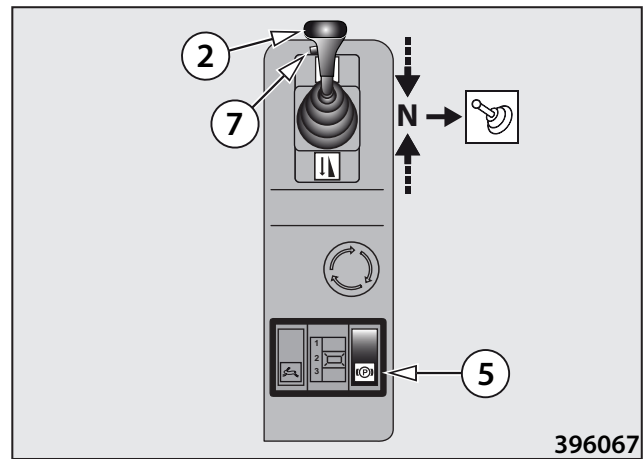

- Turn ON the IDLE switch. Turn OFF the engine via key 1 to "0" position, and pull it out - close the ignition box lid.

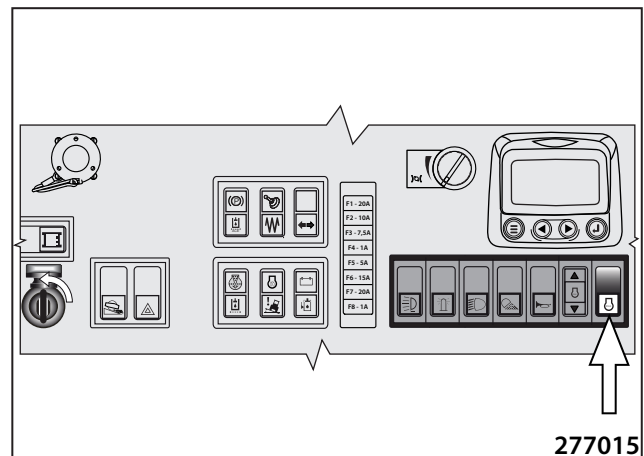

#### **! CAUTION !**

**If you wish to stand up from the seat, leave the engine and let the engine run, please switch ON the parking brake.**



**Do NOT stop hot engine instantly but let it idle for 3 minutes for turbocharger to cool down.**

## 2.7.5. Machine parking

- Stop the Machine, switch OFF battery disconnecter
- Clean the Machine to get rid of any coarse dirt.
- Carry out overall inspection of the Machine and repair any defects that occurred during operation.
- Check sufficient pressure in tyres.
- Use scotch blocks to secure the wheels and drum.
- Lock the covers of instruments or cab and door underneath the Driver's control stand.



**Switch off the battery disconnecter no sooner than 30 seconds after removing the key from the ignition switch.**

**Keeping of the time limit is necessary for saving the data of the ECM motor.**

**Shut down the Machine on flat and paved surface. Confirm there is no potential of natural hazard (landslide, potential flooding due to any deluges, etc.) at the location.**

## 2.7. Machine control and use

### 2.7.6. Cab and bonnet raising and lowering



Before lifting Driver's control stand with the Machines that have a canopy with ROPS, please fold down the backrest and arms.



- Open door 1, remove pump lever 2. Levers for lifting - dropping 3.

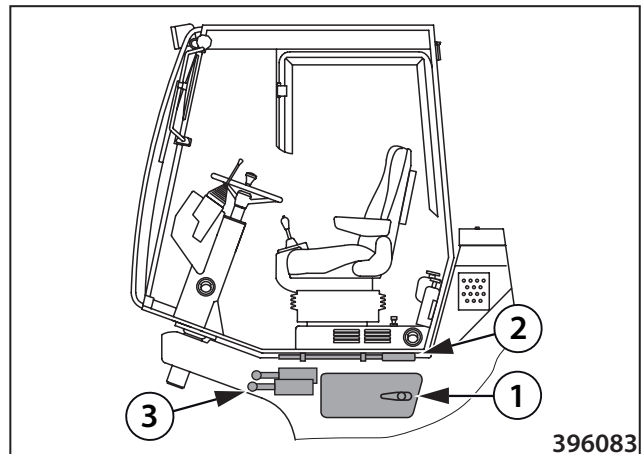

- Do pumping on hand hydrogenerator to lift - drop the cab or bonnet.

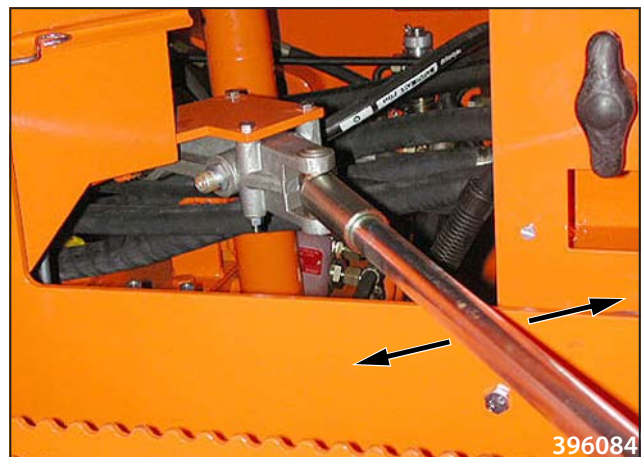

- Before lifting, please unlock the cab.



## Cab - 1

### Bonnet - 2

- Lever up - lifting
- Lever down - dropping

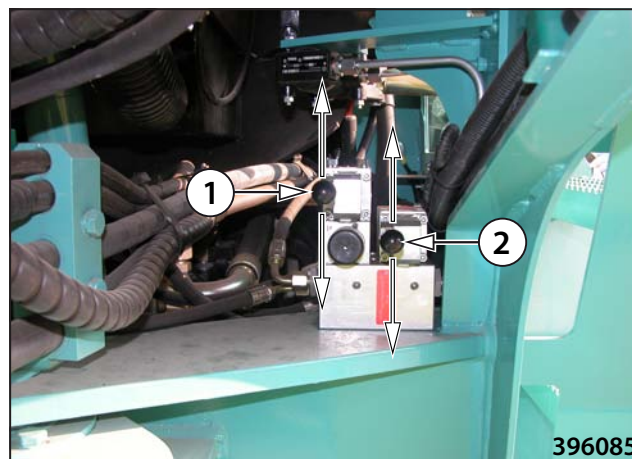

### Electric-hydraulic control (optional)

- Connect wiring by turning battery disconnecter 1. Press pushbutton 2 to position "A" to lift the cab, or pushbutton 3 to lift the bonnet. To drop you must press pushbuttons to position "B".

### Note

When unit (aggregate) is broken, or battery discharged, please lift - drop the cab or bonnet by pumping on hand hydrogenerator with the distributors adjusted as seen hereinafter. The distributors are located underneath the cab, inside the frame, on LH side.

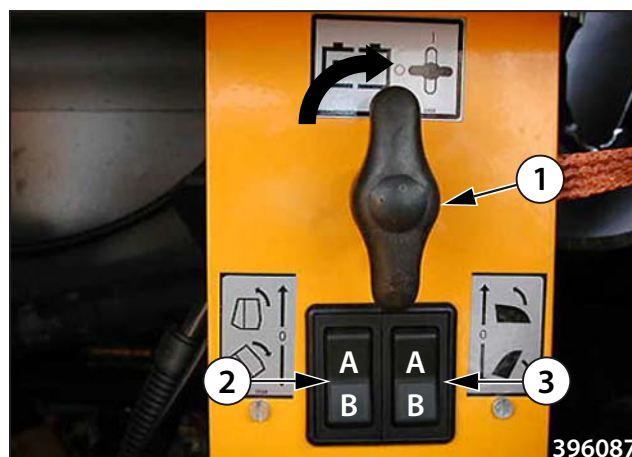

### Cab

- To lift manually you must plug in the slide 1 on distributor A, secure with safety pin 2. Before dropping, please unlock the safety pin.

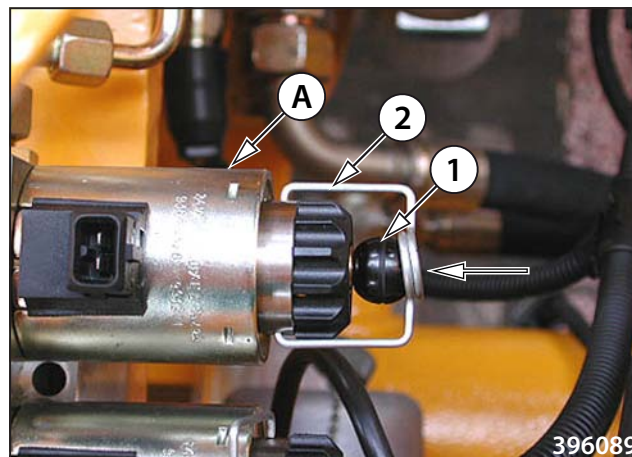

- To drop you must plug in the slide 1 on the second side of distributor A, secure with safety pin 2.

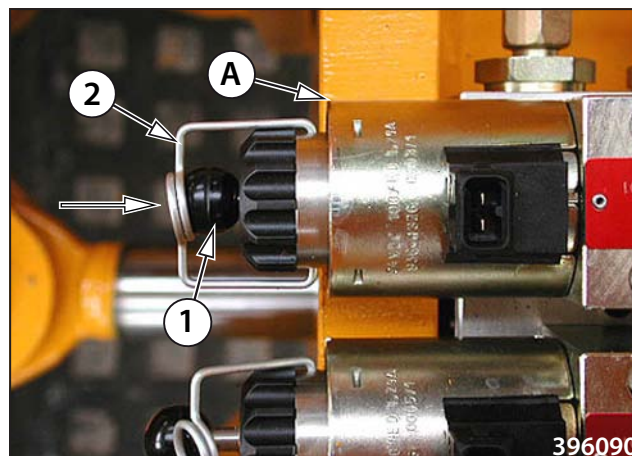

## 2.7. Machine control and use

### Bonnet

- To lift manually, please plug in slide 1 on distributor B and secure with safety pin 2. Before dropping, please unlock the safety pin.

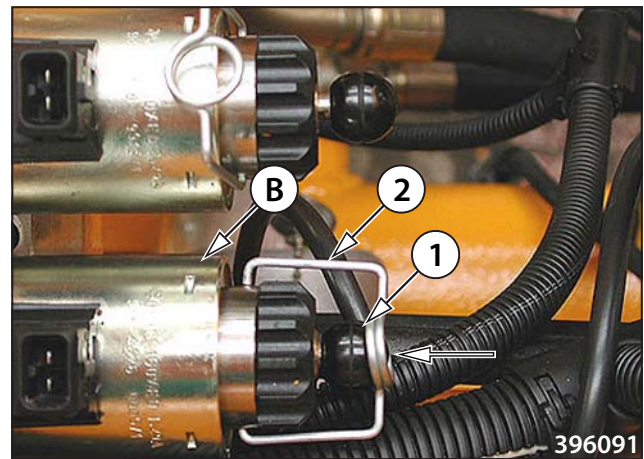

- To drop you must plug in the slide 1 on the second side of distributor B and secure with safety pin 2.

### Note

Remember to unlock the safety pin before dropping.



**Once dropped, please bolt the Driver's control stand (cab)!**

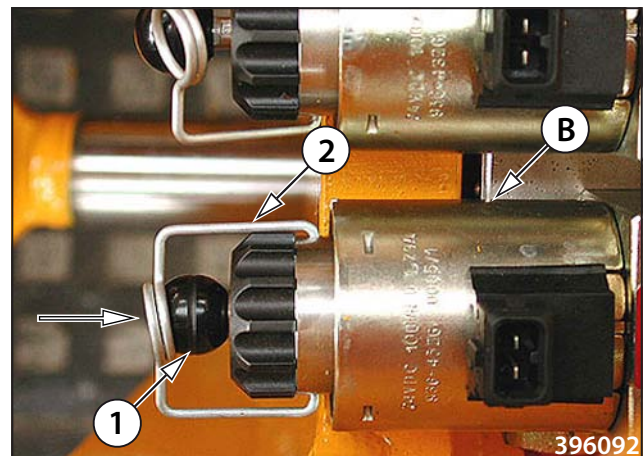

2.7.7. Blade

- Unlock the blade on both sides. Unlocked blade

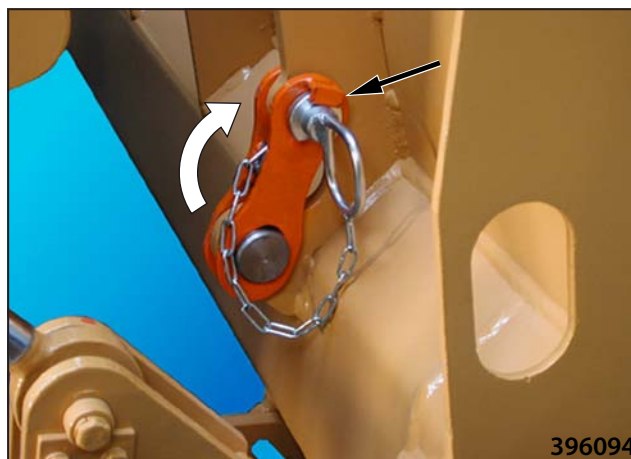

396094

- Control function is given by four positions:
 

0 position	basic position
Position I	blade going down
Position II	blade ascending
Position III	blade is in floating positions

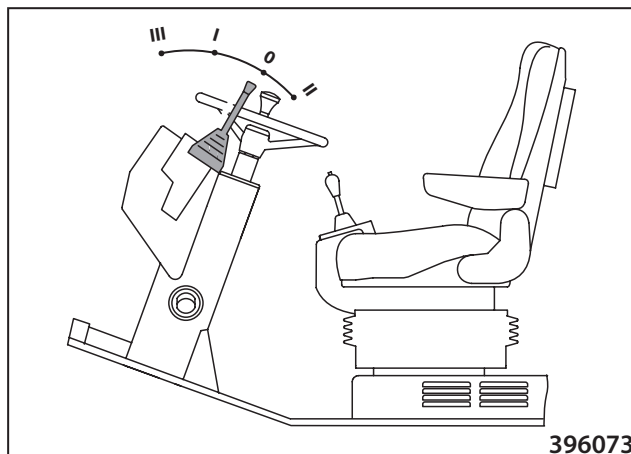

396073

- Drop the blade to the ground via shifting the actuator to "III" position (floating position)

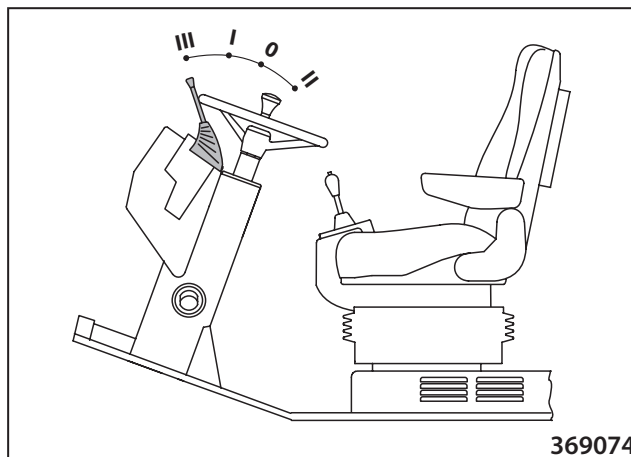

369074

or via the pedal.

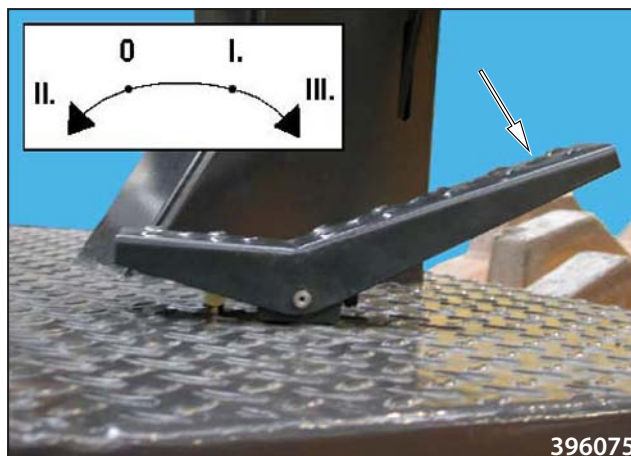

396075

## 2.7. Machine control and use

- Find out mutual position of fixed indicator 1 against mobile indicator 2. This is the basic position of the blade.

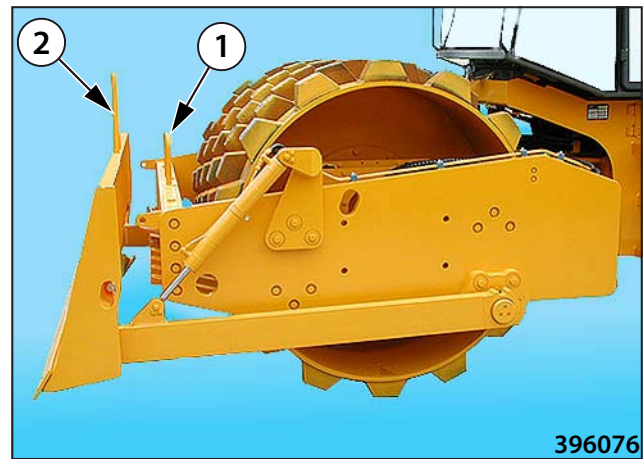

- Return controller (pedal) to "0" position and start moving the Machine.

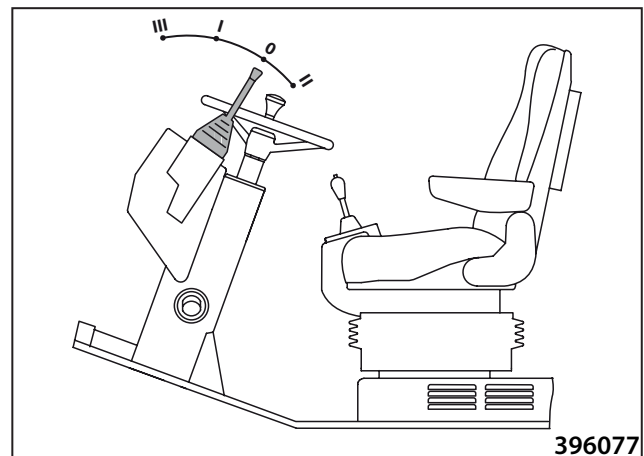

- You may sink the blade through shifting the controller (pedal) to "I".

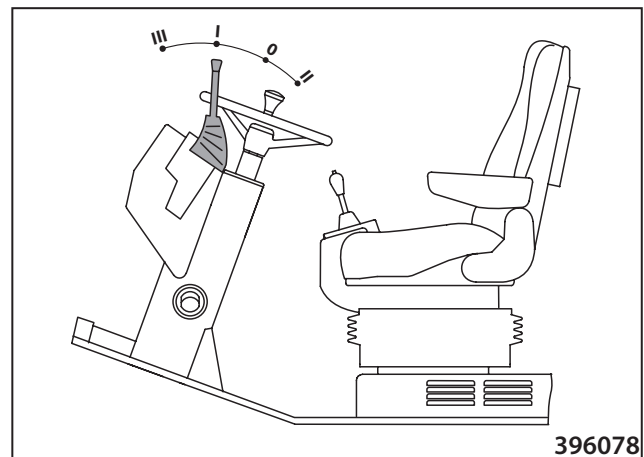

- Read the size of sinking from mutual position of fixed and mobile indicators 1, 2. Shifting by one gap (from one diagonal to the second one) the blade will shift by 50 mm.

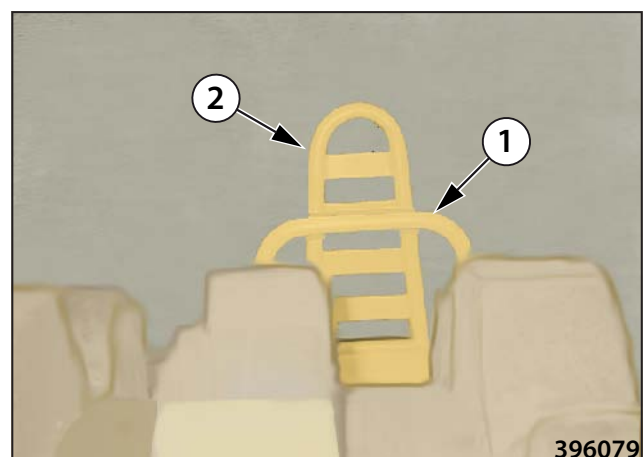

- Floating blade can be used when bulldozing a material on a paved area. Floating position may also be applied when spreading and levelling again the material being spread. The blade will skim on removable skids.

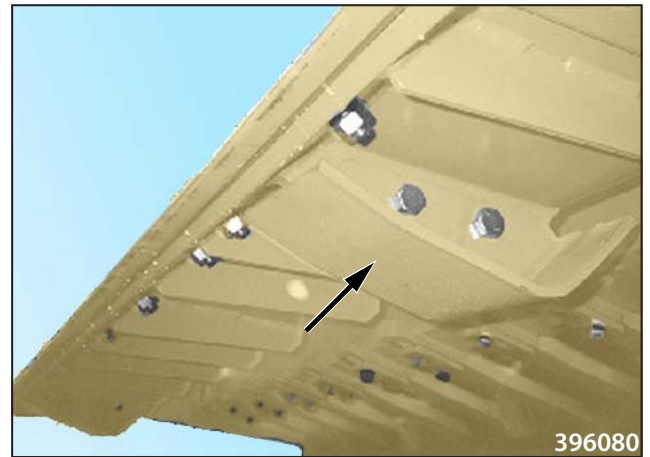

- When work with blade is completed, please secure it in its upper position with the help securing tie rods 1 and pivots 2 on both sides.

**Note**

The blade edges are able to dismount, and when worn out you may turn them round by 180°.

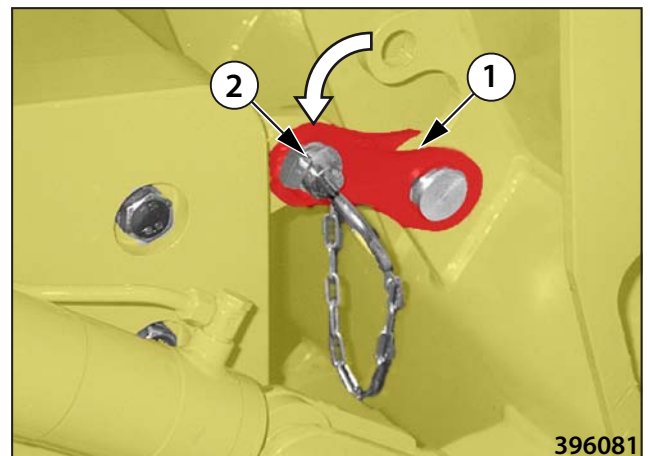

**Do NOT perform any adjusting of scrapers or any work on the blade unless blade is descended on the ground and engine stopped, or unless blade is secured with both locking tie rods.**



**Do not operate the blade if it is locked. If attached to one securing tie rod, there is hazard of blade damaged.**

## 2.7. Machine control and use

### 2.7.8. Filling tyres with water

It is used for lowering the machine gravity centre. An advantage is that the solution in tyres does not increase the axle load.

The inner space of the tyre is filled with the solution of water, slaked lime (calcium hydroxide) and anhydrous calcium chloride  $\text{CaCl}_2$  or magnesium chloride  $\text{MgCl}_2$ . The mixing ratios for individual temperature per one tyre are given in the table.

Freezing point	Water	Calcium chloride $\text{CaCl}_2$	Calcium hydroxide	Added weight
(°C) [°F]	(l) [gal US]	(kg) [lb]	(kg) [lb]	(kg) [lb]
-18 [0]	458 [121]	120 [365]	2 [4,4]	580 [1280]
-25 [-13]	458 [121]	141 [312]	2,2 [4,9]	600 [1323]
-30 [-22]	458 [121]	155,5 [343]	2,5 [5,5]	617 [1360]

A filler neck can be ordered as a replacement part under number 4-322839.

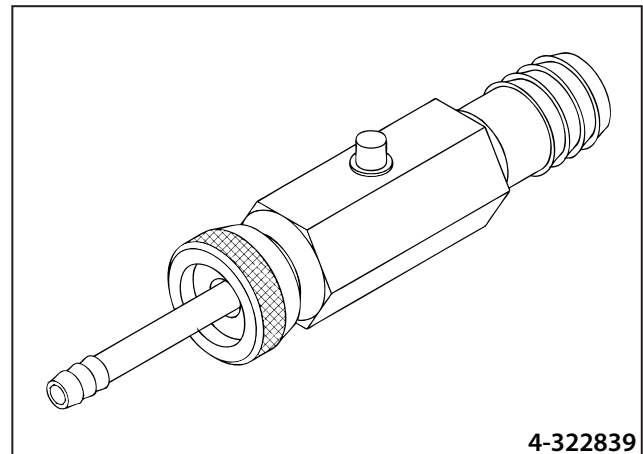

#### Filling procedure:

- Move the machine to a firm base. The filling valves should be in the extreme upper position. Secure the drum with blocks on both sides.
- Unscrew the removable valve insert and screw on the filler neck.

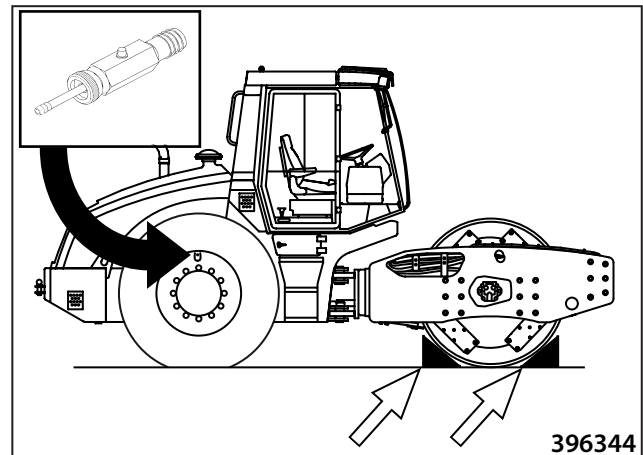

- Mount the hose from the filling equipment (a tank located above, pump, etc.) on the filler neck and fill the tyres with the solution.
- During the filling, air escapes from the tyre through the side opening from the filler neck. The tyre is sufficiently filled (at 75%) when the solution starts flowing out through the opening.
- Unscrew the filler neck, screw the valve insert back on, and inflate the tyre to a pressure of 150 kPa (21.7 PSI).

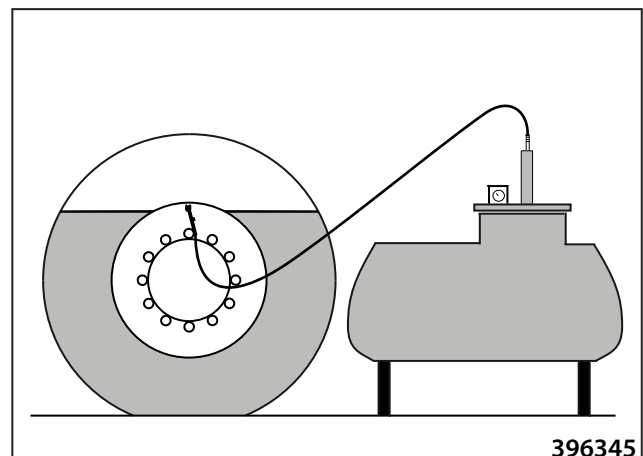

## Draining procedure:

- Move the machine to a firm base. The filling valves should be in the extreme lower position (1). Secure the drum with blocks on both sides.
- Unscrew the removable valve insert and let the solution flow out.



**The solution can spurt out after unscrewing the valve insert.**

- As soon as the solution does not flow out due to a decrease in pressure, screw on the filler neck and inflate the tyre to a pressure of 150 kPa (21.7 PSI).
- After the tyre has been inflated, remove the filler neck and screw the valve insert back on.



**Protect your eyes with glasses (face shield) and your hands with rubber gloves!**  
**Add anhydrous calcium chloride  $\text{CaCl}_2$  to water, never vice versa!**



**Wash away spilled solution with clean water.**  
**Solution may never come into contact with metal parts and wiring.**

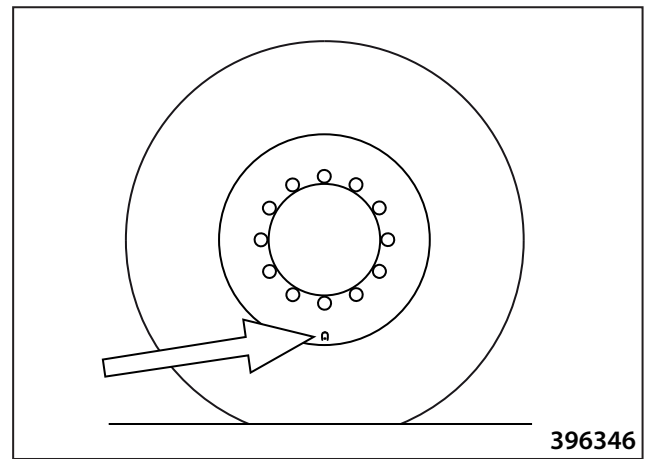

## 2.8. How to transport the Machine

- The machine can move on its own between working sites.



**When moving on the working site, observe the safety measures applicable to the working site.**

**When driving for long distances, 1-hour cooling breaks after 3 hours of driving should be taken. Failing that, you are exposed to the risk of damage to the machine for which the manufacturer is not responsible.**

- When on the road, the machine should be transported on a vehicle.



**When transporting the machine on a vehicle, observe the regulations in force in the given territory.**



**Make sure the transport carrier is braked and mechanically secured against undesired motion with scotch blocks 3 when loading or unloading.**

**When moving onto the transport carrier you must switch ON the function of Drum Slip Limitation. At the same time we recommend to put rubber bands or wooden planks, etc. underneath the drum.**

**The machine on the vehicle must be properly tied and mechanically secured against longitudinal and lateral displacement as well as against tipping 1. The drums must be secured using scotch blocks 2. The maximum permitted force for fastening the machine to a vehicle using rear slings is 5 t.**

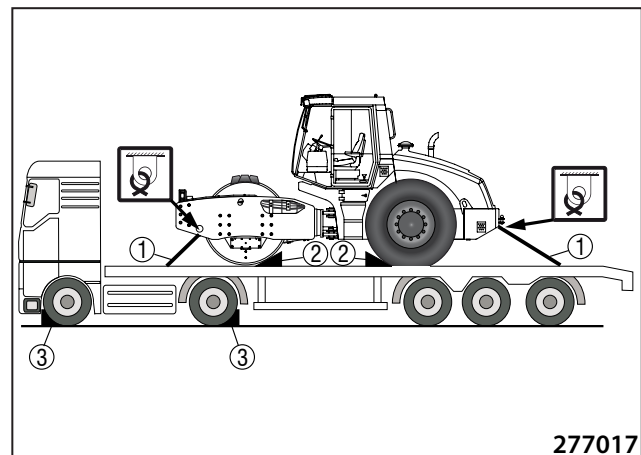

## 2.8.1. Machine loading

- Use loading ramps or crane to load the Machine onto the transport carrier.
- When loading with crane the Roller is fitted with lifting lugs - refer to the Fig. showing the lifting method.
- When lifting the Roller the Machine's joint shall be secured against turning.



**When loading and unloading the machine, it is necessary to observe the provisions of ISO 12480-1 and to use slings under EN 1492-4+A1.**

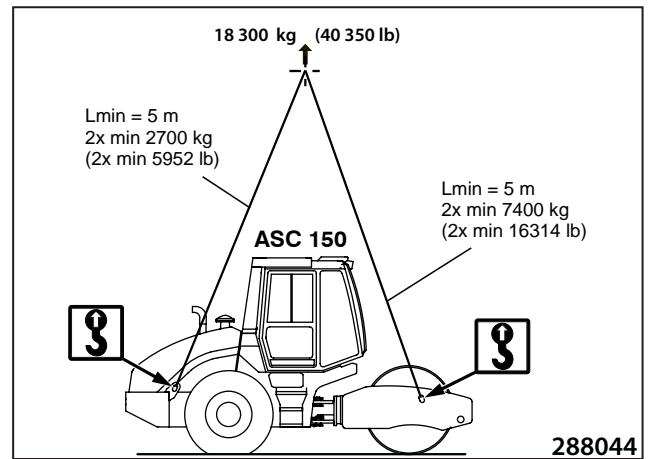

### How to secure the joint:

- Fold down the arm 3, turn the cotters (scotch blocks) 4, insert pins 1, 2, lock with safety pin.

### Note

The scotch blocks are optional.



**Do NOT enter the area under the lifted load!**

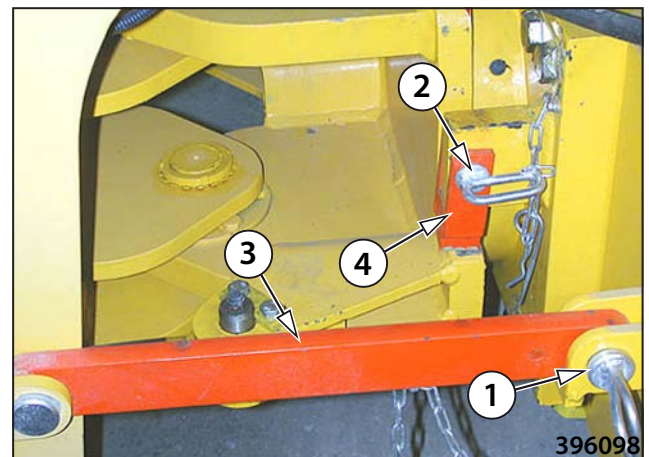

**Upon loading completion, please return the safety arm and cotters to their initial position.**

**Use corresponding, undamaged riggings of sufficient loading capacity.**

**To sling, please use only the lifting lugs on the Machine designed for that purpose.**

**Only a trained slinger may carry out the slinging.**

## 2.9. Special conditions of the Machine use

### 2.9.1. Machine towing

- To tow the Machine is equipped with the following: two eyes 1 on the drum frame, plus front towing attachment 2 (optional).

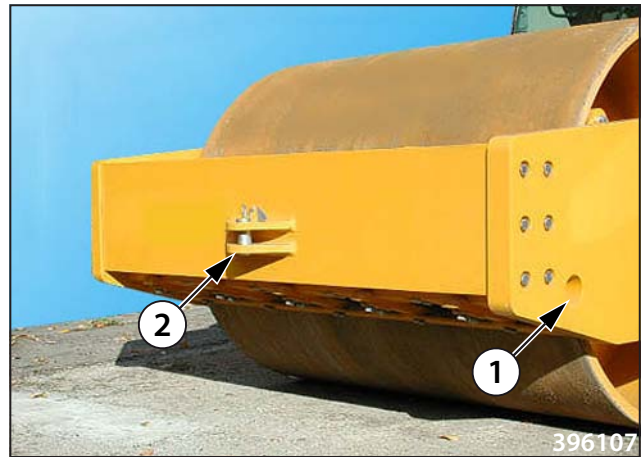

Rear towing attachment.



**When towed the Machine shall be attached with both lugs!**

**It is forbidden to use the Machine for hauling towed units (e.g. tankers, compressors, dwelling cells, etc.).**



#### How to brake off:

- Disconnect hose 1 in the quick-coupling 2.

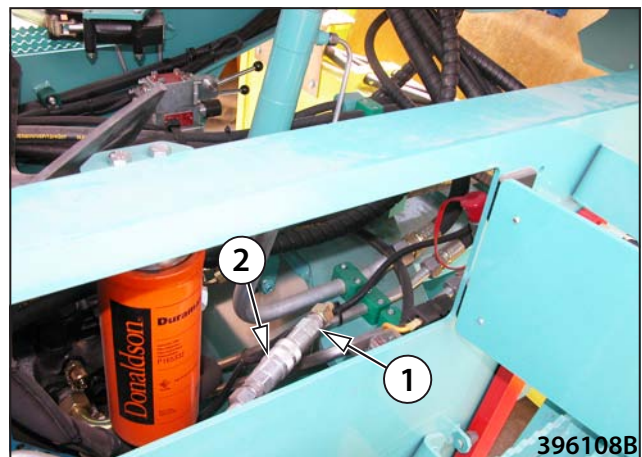

- Loosen hose 3 in the clamp, and connect with quick-coupling 2.

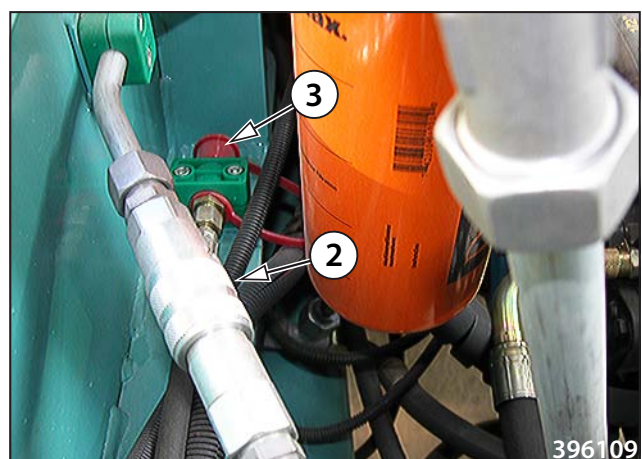

- Cut short the hydraulic circuit of the travel through loosening the centre parts of both multifunctional valves by 3 turns in CCW direction. Spanner 27 mm, (11/16")

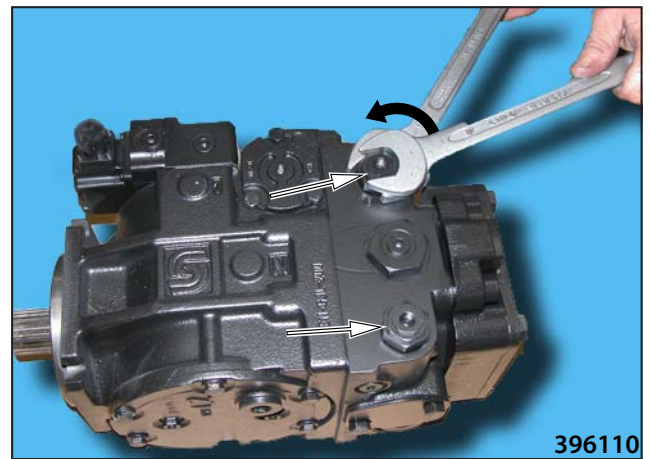

- Pump with the use of hand hydrogenerator.

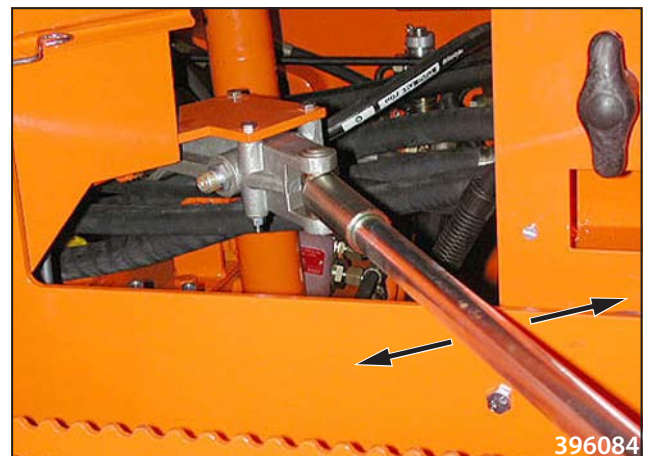

- Watch until brake indicator lamp goes OFF with the ignition key turned ON. Now the Roller is braked off.



**When towing is completed, please secure the wheels and drum with scotch blocks (cotters), and put into initial state.**

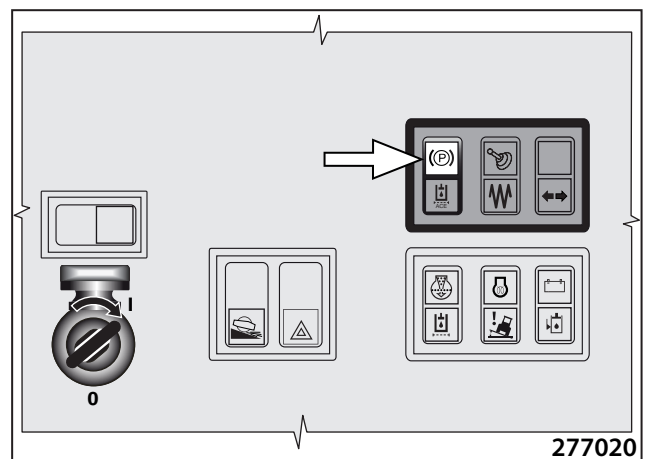

### How to put into initial state

- Screw back the multi-purpose valves on the travel hydrogenerator.
- Disconnect hose 3 at the quick-coupling 2.
- Connect hose 1 back with pressure filter quick-coupler 2.
- Attach hose 3 in clamp.
- Put hand hydrogenerator lever into the holder underneath the Driver's control stand.

## 2.9. Special conditions of the Machine use

---



**When braking off the gearbox, hydro motors and short-circuiting the hydraulic loop of the travel, it will not be possible to use operating, emergency or parking brakes! All brakes are now disabled!**

- These are general requirements for safe hauling of a broken Machine under normal conditions. Any and all different situations that may occur while hauling, shall be discussed with the dealer.



**Due to the seepages the pressure may drop when towing; check brakes do not heat up due to insufficient braking off.**

**When towing, please use undamaged towing cable or pull rod of sufficient loading capacity 1,5 higher than the weight of hauled Machine. It is forbidden to use a chain for hauling.**

**No person may stay on a towed Machine where engine does not work.**

**It will be necessary to maintain minimal deflection from direct angle of hauling. Max deflection will be possible within angle of up to 30°.**

**It will be required to keep moving continuously when hauling. Do NOT exceed hauling speed of over 2 km/hr. (1.2 mph).**

**The machine should only be towed for the shortest possible distance – to extricate the machine if it gets stuck or is blocking traffic in case of breakdown. Do not tow the machine for a longer distance than 300 m (0.19 mi).**

**The hauling machine shall fit with its size the Machine broken. It shall have sufficient hauling force (performance), weight and brake effect.**

**When hauling downhill with the help of cable it will be necessary to attach next hauling machine to the rear part of the Machine broken. In this way it will be possible to avoid uncontrolled motion of the Machine damaged.**

**Do NOT start the engine when towing the Machine.**

**A sunk Roller can be hauled for a short distance if its engine is running and the drive and steering work. Driver on hauled Roller must steer the Roller in hauling direction.**

**Unless the engine works, measures have to be taken to avoid any damage to the steering, drive and brake that are not effective.**

## 2.9.2. Machine operation during running-in

When putting a new machine into operation, the machine should not be run at full power for the first 50 hours (driving uphill with vibration).

## 2.9.3. Machine operation at low temperatures

Compacting in winter season depends on the content of fine particles and water in the soil being compacted. With the temperature declining below freezing point the soil becomes more solid and harder to compact.

It necessary to compact at the temperatures below 0 °C (32 °F) then it is possible to compact dry soil (and stony loose materials) or make swift compaction of non-frozen materials (before earth freezes through).

Preparation for work under low temperatures:

- Check concentration of engine cooling liquid.
- Exchange oil in the engine with the recommended one for given range of low ambient temperatures.
- Use hydraulic oil of corresponding cinematic viscosity.
- Oil in drum gearbox, replace with recommended one for given operating temperature range of the gearbox.
- Use winter fuel.
- Check the batteries are recharged.

### Note

Warm the batteries to ca 20 °C (68 °F) (removing the batteries and storing them in a warm room) to lower the limit temperature for starting by 4 to 5 °C (39,2 to 41 °F).



**Min temperature of engine cooling liquid is 60 °C (140 °F). Max temperature of 100 °C (212 °F).**



**You may use the Machine at its full capacity only after heating the media to their operating temperature (cooler possible to be partially covered).**

### **! CAUTION !**

**When using HV 100 oil in the hydraulic system NEVER start the Machine at ambient temperatures below +2 °C (36 °F).**

**If required to start the Machine for the period of one month or longer at ambient temperatures below -8 °C (18 °F), replace oil in hydraulic system with the oil of HV 46 viscosity class.**

**At temperatures below -13 °C (9 °F) with oil of HV 32 class.**

**It is impossible to start the Machine below -23 °C (-9 °C) with no preheating of filling media.**

## 2.9. Special conditions of the Machine use

---

### 2.9.4. Operating the Machine at high temperatures and humidity

The higher the air temperature and humidity the lower the engine performance is. Both factors reducing the performance are dependent on each other:

- Each 10 °C (50 °F) increase of temperature means capacity drop of up to 4 % (at constant humidity)
- Each 10 % increase of relative humidity means capacity drop of up to 2 % (at constant temperature).

Machine cooling will improve through hot air removal away from engine compartment when you remove the fender shields of the bonnet.

#### Note

For oil of HV 46 class the max admissible oil temperature will be 80 °C (144 °F), for HV 32 oil the max admissible oil temperature will be 70 °C (158 °F).

In the environment where hydraulic oil temperature stays constantly round 90 °C (194 °F) we recommend to exchange hydraulic oil for oil denser by one class, with HV 100 cinematic viscosity.



## 2.9.5. Operating the Machine at high altitudes

With higher altitudes the engine capacity will drop due to reduced atmospheric pressure and specific weight of air induced.

If the engine has black smoke at high altitudes (over 1500 m), please contact engine Manufacturer's service centre who will make adjustment to your fuel injection pump for these operating conditions.



**The engine power is affected by the environment in which the machine is working.**

**The machine may be used up to a maximum altitude of 3,658 m (12,000 ft).**

## 2.9.6. Work of the machine in the dusty environment

When operating in very dusty environment, you must cut short the intervals for cleaning and replacement. Cut the intervals of cleaning the engine cooler, hydraulics, and also of the replacement of cab's dust filter.

## 2.9.7. Driving with vibrations on compacted and hard materials

When operating the Machine with vibration on hard materials (e.g. stony loose material), or with high level of compacting the base material, there can be even loss of contact between the drum and the material compacted (so called vibro-hit). This state will show in the increased vibration transfer into the Machine frame and onto the Driver's control stand. Its partial elimination is possible via increasing the travel speed or changing the Machine vibration parameters (with the use of lower amplitude).

When it is necessary to operate the Machine under conditions where the Operator might be exposed to higher vibrations, then the Machine Operator will be liable to adjust the work procedures so as to prevent any injury to Driver's health.

### Note

When driving the Machine with vibrations on a different base material than stated in "Specification Manual", the emission figures for vibration acceleration will be different - section called "Noise and vibration emissions".



<b>Notes</b>

---

# **3. MAINTENANCE MANUAL**

## **ASC 150 (Cummins Tier 3)**

---

## 3.1. Safety and other measures for machine maintenance

### 3.1.1. Safety of machine maintenance

#### Carry out lubrication, maintenance and adjustments:

- By professionally trained personnel
- In line with safety instructions given in the Operation Manual
- According to schedule given in the Lubrication Chart following the hours actually worked
- On the machine located on flat solid surface, secured against self-motion (scotch blocks), and this always with the engine OFF, key removed from ignition box, and the wiring cut off
- Only after **Machine Repair** sign is attached onto steering wheel (the sign is supplied together with machine accessories)
- On machine parts cooled out
- After having cleaned the machine, lubrication points and maintenance locations
- Using proper, undamaged tools
- Through replacement with new original parts as per the Spare Parts Catalogue
- With sufficient lighting of the entire machine in the event of lowered visibility and at night
- so the guards and safety elements are reinstalled again upon work completion
- through retightening bolted connections – with torque specified, and through checking the connection tightness
- with the operation media heated – beware of burns – use recommended media, only.

### 3.1.2. Fire precautions during operation media exchanges

- In terms of fire hazard the flammable liquids used on the Machine have been divided into three hazard classes:
  - II<sup>nd</sup> Hazard class – Diesel oil
  - IV<sup>th</sup> Hazard class – mineral oils, lube greases
- Oil exchange point shall be located so it does not interfere with the explosion or fire hazard area.
- It shall be identified with notice boards and signs of no smoking and no use of open flame.
- Handling area shall be sized so the capture the amount to flammable liquid equal to the capacity of biggest vessel, transport container.
- It must be equipped with portable fire extinguishers.
- To handle the oil, Diesel oil, please use such vessels like metal barrels, canisters or sheet-metal cans.
- Transport containers shall be properly closed when stored.
- Vessels shall have one opening, be stored with the opening on top, and secured against any flowing out or dripping of their content.
- Vessels shall be designated with indelible inscription indicating the content and flammability class.



**Upon completion of the adjustment or maintenance, please examine the function of all safeguard equipment!**

## 3.1. Safety and other measures for machine maintenance

### 3.1.3. Ecological and hygienic principles

When operating or maintaining the Machines the user shall be liable to follow the general principles of health and environment protection according to the laws, ordinances and regulations in individual territories of the Machine use.

#### Hygienic principles

- Crude oil products, cooling system media, battery media and coating compositions incl. thinners are materials harmful to health. Workers coming into contact with these products during machine operation or maintenance shall be liable to follow the general principles of their own health protection and conform to the safety and hygienic manuals of these products' manufacturers.

We call your attention to the following in particular:

- Eye protection and skin protection during work with the batteries
  - Skin protection during work with crude oil products, coating compositions or cooling liquids
  - Proper hand washing upon work completion and before any meal; use adequate reparation cream to treat your hands
  - Adherence to the instructions given in this Manual
- 
- Always store the crude oil products, cooling system media and battery media, and coating compositions incl. organic thinners, and also the cleaners and preserving agents, in the genuine, original and properly labelled packages. Do not admit any storage of these materials in unlabelled bottles or in any other vessels with regard to the hazard of mistaken identification (faulty change).
  - When skin, mucosa, eyes are accidentally stained, or vapours inhaled, immediately apply the first aid principles. In the event of accidental use of these products get prompt medical attention.
  - When working with the Machine in cases where the Machine has platform fitted, cabin windows are left opened, always use ear protectors of adequate type and version.

#### Ecological principles



**The media of Machine's individual systems, and some of its parts after having been discarded (dismantled, media exchanged) become waste with hazardous properties against the environment.**

This category of waste products includes the following in particular

- Organic and synthetic lubricating materials, oils and fuels
- Brake fluids
- Cooling liquids
- Battery media and the batteries themselves
- Cooling system media
- Cleaners & preserving agents
- All dismantled filters and filter elements
- All used and discarded hydraulic or fuel hoses, rubber-metal and Machine's other elements, made dirty due to the abovementioned products.



**The given materials and parts, when scrapped, shall be handled compliant to the respective national regulations on environmental protection, and in line with the health protection regulations, as well.**

### 3.2.1. Engine oil



Engine oil is specified by its performance and viscosity classifications.

#### Performance classification according to

API (AMERICAN PETROLEUM INSTITUTE)

CCMC (COMITE of COMMON MARKET AUTOMOBILE CONSTRUCTORS).

ACEA (ASSOCIATION DES CONSTRUCTEURS EUROPÉENS DE AUTOMOBILE)

#### Viscosity classification

To determine SAE (Society of Automotive Engineers) viscosity class, the ambient temperature and type of operation in place of usage of the machine are decisive.

Permitted oil according to API: CH-4/SJ; CI-4/SK

All season - SAE 15W-40 (e.g. Valvoline, Premium Blue,).

#### NOTE

Exceeding of the lower temperature limit does not damage the engine, it may only cause starting problems.

It is suitable to use general-purpose multi-grade oil in order that oil need not be exchanged because of ambient temperature changes.

Use of synthetic engine oils is permitted subject to the same performance and viscosity limitations of mineral (petroleum) based engine oils. The same oil change intervals must be applied to the synthetic oils that are applied to mineral (petroleum) based engine oils.

For easier start at temperatures below 0 °C (32 °F), SAE 10W-30 oil is recommended by the engine manufacturer.

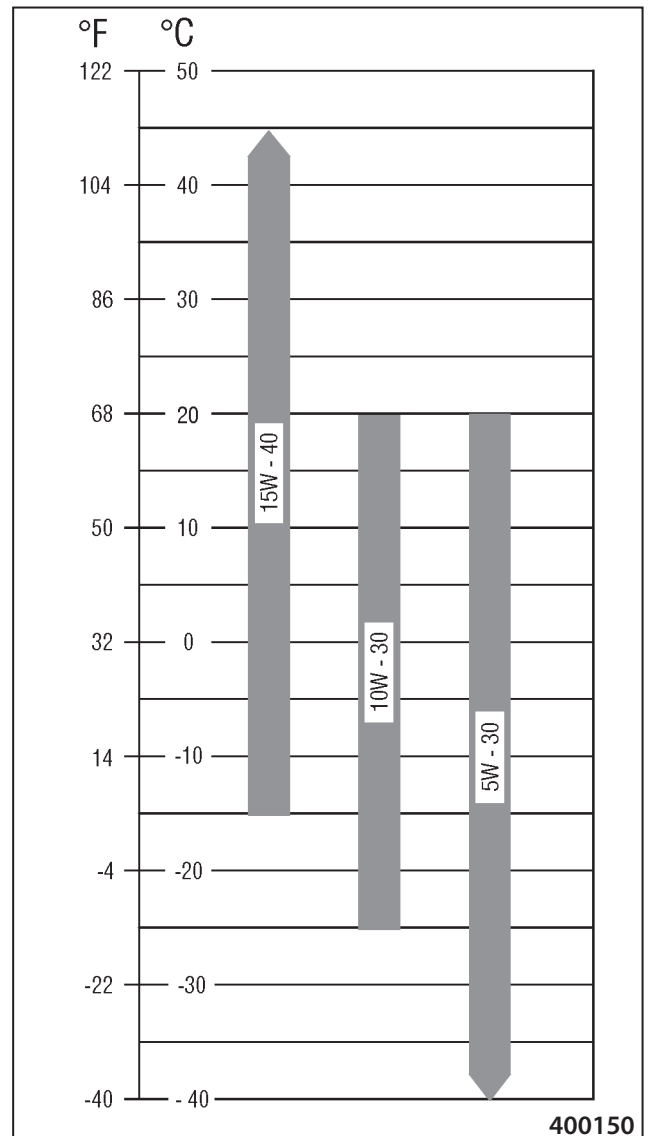

**Exceeding the upper temperature limit must not last for long, taking into consideration reduced lubricating properties of oil.**

**When using oil according to API CG-4/SH, the exchange interval should be cut to one half, i.e. 250 hours or 3 months.**

## 3.2. Specification of fluids

### 3.2.2. Fuel



Diesel is used as fuel:

- CEN EN 590
- ASTM D 975-88: 2-D

#### NOTE

Engine producer recommends to use fuel with sulphur content less than 0.05 weight percent.



**Therefore use winter Diesel fuel at outdoor temperatures below 0 °C (32 °F). Special Diesel fuel with additives intended for very low temperatures must be used at outdoor temperatures below -15 °C (5 °F) ("super Diesel").**

#### Use of biofuel (Diesel fuel)

Using the fuel mixture under the trade name of Bionafta is in principle approved by the engine manufacturer for the engine on the machine if it conforms to the specifications under EN 14214 or ASTM D6751.

Before using Bionafta on the machine, make sure that it is supplied by a reputable supplier who supplies fuels corresponding to the above-mentioned standards.

Always ask the supplier of Bionafta for information concerning the condition under which it can be used.



**Guarantee for the engine will be rejected when using Bionafta not conforming to the above-mentioned standards and if the fuel system or engine is damaged as a result of using improper Bionafta!**

#### ! CAUTION !

**When using Bionafta, power can be reduced by up to 12% depending on the used mixture of Bionafta. Therefore, do not adjust the engine or the setting of the injection pump for increasing the power in any case. Never mix the fuel mixture at the place of use. Bionafta has a higher cloud point at a low ambient temperature, which leads to the creation of wax crystals in the fuel resulting in the fuel filter clogging.**

**When using Bionafta, it is necessary to shorten the intervals of the engine oil exchange and replacement of an oil filter and fuel filter.**

**When changing over to Bionafta, the action of Bionafta releases corrosion and impurities created on the fuel tank internal walls. Impurities are brought by the fuel to the filter catching them and the filter must be replaced afterwards.**

**Bionafta has a higher ability to absorb atmospheric moisture, which results in the condensation of atmospheric moisture on the internal walls of the tank and a higher content of water in the fuel and the need for more frequent discharging of water from the fuel filter separators. The possibility of the occurrence of the problem increases in cold weather.**

**If Bionafta (Biodiesel) is used all the year round, it is necessary to clean the fuel system under the engine operation with a clean diesel fuel for at least 30 minutes before parking the machine for longer than 3 months. Further, it is necessary to drain off the fuel tank, clean it, and either fill it with diesel fuel or minimise the occurrence of moisture and limit the microbiological growth inside the tank. Consult the measures with the fuel supplier.**

3.2.3. Coolant



Use coolant consisting of 50% of frost-resistant ethyl glycol agent and water. Use the coolant with antifreeze even in zones where temperatures do not fall below -36 °C (-34 °F). The coolant is not only protecting the cooling system against frost but increases also the boiling point. Inhibitors contained in the antifreeze protect parts of the engine cooling system and extend their life. Propylene antifreeze may also be used as coolants.



**Do not use more than 50% of antifreeze in the coolant, unless absolutely necessary.**

**Never use a ratio higher than 68 %.**

**Their mutual mixing is not recommended. Anti-corrosive properties may be lost when mixing different types of coolants.**

**Nitric amines dangerous to health are formed when mixing the nitride-base antifreeze and the amine-base agent.**

**Check the ratio of antifreeze in the coolant before wintertime using a refractometer (hydrometer).**

3.2.4. Hydraulic oil



For use in the hydraulic system of the machine, only high-quality hydraulic oils of output class according to ISO 6743/HV (equal to DIN 51524 part 3 HVLP; CETOP RP 91 H).

Standardly refill the machines with hydraulic oil of kinematic viscosity 68 mm<sup>2</sup>/s at the temperature of 40 °C (104 °F) ISO VG 68. This oil is the most suitable one to use in the broadest range of ambient temperatures.



**At high ambient temperatures, when the oil temperature reaches continual 90 °C (194 °F), we recommend replacing the oil with one of kinetic viscosity 100 mm<sup>2</sup>/s – HV.**

**Should it be required to start the machine at temperatures below –8 °C (18 °F) lasting more than one month, replace oil in the hydraulic system with one of kinetic viscosity 46 mm<sup>2</sup>/s - viscosity class HV 46.**

**At temperatures below –13 °C (9 °F), replace oil with one of kinetic viscosity 32 mm<sup>2</sup>/s - viscosity class HV 32, see Operating Instructions chapt. 2.9.3.**

**Synthetic hydraulic oil**

Hydraulic system can be filled with synthetic oil, that is completely degradable by microorganisms found in water and soil in case of leak.



**When changing over from mineral oil to synthetic or when mixing oils of different brands, always consult the procedure with the oil manufacturer or dealer!**

## 3.2. Specification of fluids

### 3.2.5. Gearbox oil



Use high quality oils complying with API GL-5 or EP or MIL-L-2105 C for lubricating the drum gearbox and axle (wheels) drive gearboxes.

Viscosity SAE 80W/90 for outdoor temperature range  $-10\text{ °C} \div +30\text{ °C}$  ( $14\text{ °F} \div 86\text{ °F}$ ).

Viscosity SAE 80W/140 for outdoor temperature range  $+20\text{ °C} \div +45\text{ °C}$  ( $68\text{ °F} \div +113\text{ °F}$ ).



**The operating oil temperature must not exceed  $85\text{ °C} \div 90\text{ °C}$  ( $185\text{ °F} \div 194\text{ °F}$ ).**

### 3.2.6. Lubricating grease



Plastic grease containing lithium in compliance with NLGI-2 regulation (Mobilplex EP-1, Retinax A, Alvania, Grease No 3 etc.) must be used to grease the machine.

ISO 6743/9 CCEB 2

DIN 51 502 KP2K-30

### 3.2.7. Windshield washer liquid



Water (at temperatures down to  $0\text{ °C}$ ) and windshield washer agent are used as fills in the washer can.



**Replace water with antifreeze at temperatures below  $0\text{ °C}$  ( $32\text{ °F}$ ).**

### 3.2.8. Vibrator cooling mixture











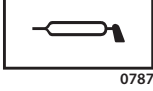

#### Mixture:

73 l of water

22,6 kg of calcium chloride -  $\text{CaCl}_2$

0,35 kg of slaked lime (calcium hydroxide) -  $\text{Ca(OH)}_2$

Fills of...	Type of fill	Quantity l (gal US)	Brand
Engine	Engine oil according to chapter 3.2.1.	11 (2,9)	 2412
Fuel tank	Diesel according to chapter 3.2.2.	410 (108,3)	 2151
Hydrostatic system	Hydraulic oil according to chapter 3.2.4.	90 (23,8)	 2158
Drum gearbox	Gearbox oil according to chapter 3.2.5.	4,8 (1,27) - HD, HDPD 5,1 (1,35) - HT, HTPD	 2186
Axle gearbox	Gearbox oil according to chapter 3.2.5.	2x2,8 (2x0,7)	 2186
Joint bearings - joint and steering cylinder	Plastic grease according to chapter 3.2.6.	as required	 0787
Engine cooling system - coolant	All year round - anti-freeze liquid according to chapter 3.2.3. for temperatures down to -25 °C (-13 °F)	32 (8,45)	 2152
Vibrator cooling mixture	Vibrator cooling mixture according to chapter 3.2.8.	80 (21,1)	 2152
Vibrating drum	Engine oil, see the engine	8 (2,1)	 2412
Battery	Distilled water	as required	 2587
Windshield washers	Water and antifreeze - ratio according to outdoor temperature	2,75 (0,72)	 2260
Tires	Air or liquid see Operating Instructions chapter 2.7.8.		

### 3.4. Lubrication and Maintenance Chart

<b>After 20 hours of operation (daily)</b>	
3.6.1.	Engine oil level check
3.6.2.	Engine cooling liquid level check
3.6.3.	Hydraulic tank oil level check
3.6.4.	Crankcase breather tube
3.6.5.	Check of the fan and engine belt condition
3.6.6.	Checking the vacuum valve of the air cleaner
3.6.7.	Checking warning and control devices
<b>After 100 hours of operation (weekly)</b>	
3.6.8.	Checking the tyre pressure
<b>After 250 hours of operation (3 months)</b>	
3.6.9.	Checking the engine inlet piping
3.6.10.	Check of the fan and engine belt condition
3.6.11.	Check of coolers
3.6.12.	Battery check
3.6.13.	Air filter sensor check
3.6.14.	Lubrication of the machine
3.6.15.	Checking oil in the vibrator
3.6.16.	Checking oil in gearboxes
3.6.17.	Inspect the pad foot segments
<b>After 500 hours of operation (after 6 months)</b>	
3.6.18.	Replacing oil in the engine
3.6.19.	Fuel filter replacement
3.6.20.	Engine cooling liquid check
3.6.21.	Checking tightening bolts of wheel
<b>After 1,000 hours of operation (after 1 year)</b>	
3.6.22.	How to check tightening pulley and belt of the engine
3.6.23.	Oil exchange in the travel gearboxes *
3.6.24.	Checking the damping system

<b>After 2,000 hours of operation (after 2 years)</b>	
3.6.25.	Checking, adjusting the valve clearance **
3.6.26.	Oil exchange in the vibrator
3.6.27.	Exchanging hydraulic oil and filter
3.6.28.	Cab and bonnet raising and lowering suction strainer unit cleaning
3.6.29.	Exchanging the engine cooling liquid
<b>Maintenance - As Needed</b>	
3.6.30.	Exchanging cleaner elements of air cleaner
3.6.31.	Cleaning of the water separator on the fuel filter
3.6.32.	Cleaning of coolers
3.6.33.	Cleaning the air cleaner of cabin ventilation
3.6.34.	Cleaning the machine
3.6.35.	Adjusting scrapers
3.6.36.	Vibrator cooling mixture
3.6.37.	Check of the screw connection tightening
<p><b>* First after 100 hours</b></p> <p><b>** First after 5000 hours</b></p>	

### 3.5. Lubrication Chart

# LUBRICATION PLAN

□	CONTROL
○	LUBRICATE
▽	EXCHANGE

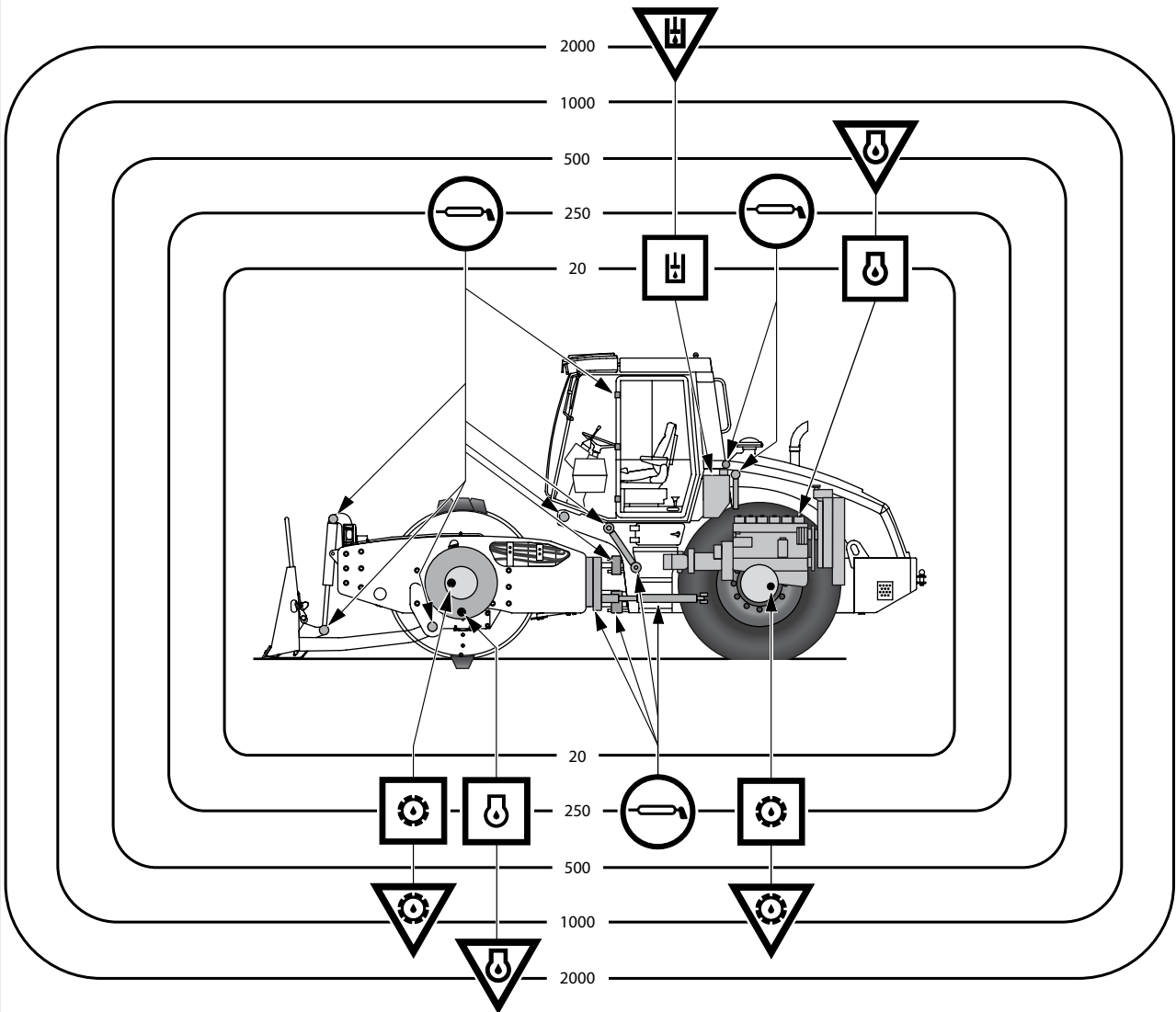

	Engine oil:	<b>SAE 15W/40</b>	<b>API CI-4</b>
	Hydraulic oil::	<b>ISO VG 68</b>	<b>ISO 6743/HV</b>
	Grease:	<b>ISO 6743/9</b>	<b>CCEB 2</b>
	Transmission oil:	<b>SAE 80W/90; SAE 80W/140</b>	<b>API GL-5</b>

282054en

### 3.6. Individual Operations of Maintenance

Carry out lubrication and maintenance on regular basis and repeatedly in the intervals as per daily reading on the counter of hours actually worked.

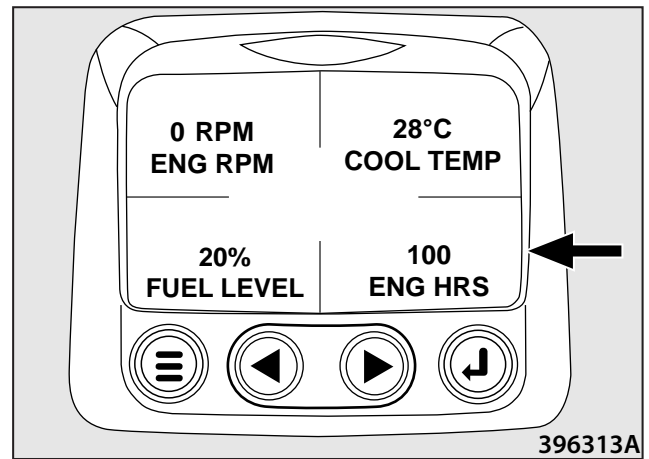

#### ! CAUTION !

This Manual states only the basic information about the engine, other data are given in the Engine Operation and Maintenance Manual which is part of the Documentation supplied with the Machine.

Tighten the removed or loosened bolts, plugs, threaded joints of the hydraulics, etc. with tightening torque according to the Chart in par. 3.6.37. unless another value is provided with the respective operation.



Carry out maintenance with the Machine placed on flat, paved surface, and secured against any self-motion, always with the engine off, and key removed from the ignition box and with the wiring cut off (unless otherwise required).

**Following the first 100 hours of operation of the new Machine (following a major overhaul) carry out as per:**

3.6.23. Oil exchange in the travel gearboxes

**Following the first 5000 hours of operation of the new Machine (following a major overhaul) carry out as per:**

3.6.25. Checking, adjusting the valve clearance

## 3.6. Individual Operations of Maintenance

### After 20 hours of operation (daily)

#### 3.6.1. Engine oil level check

- Wait approx. 5 min. until oil runs down to the engine sump.
- Take out the oil dipstick 1, wipe it, insert fully back and take it out again to read out the oil level.

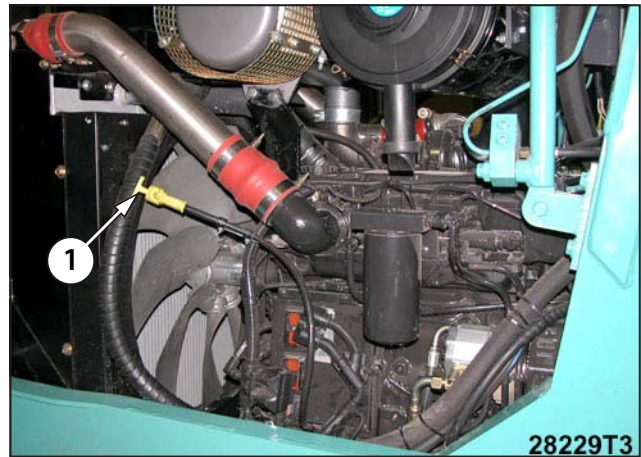

- Keep the level within the range of gauge marks pressed in the dipstick. The lower mark L (Low) marks the lowest possible oil level, the upper mark H (High) the highest one.

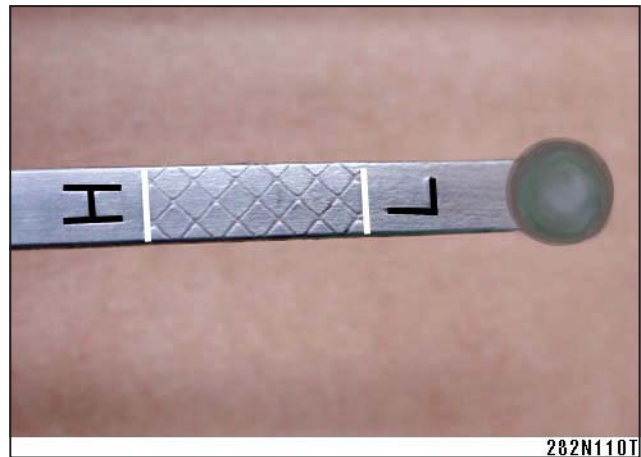

- Refill oil after removing the filler plug 2 through the oil filler. Wait approx. 1 min until the level is stable and check again.
- Refill the identical type of oil. Use oils according to chapter 3.2.1.
- Check the engine for leakage, repair possible causes.
- Check the engine for damaged and missing parts and for changes in appearance.



**Do not use the engine unless the oil level in the engine is correct.**

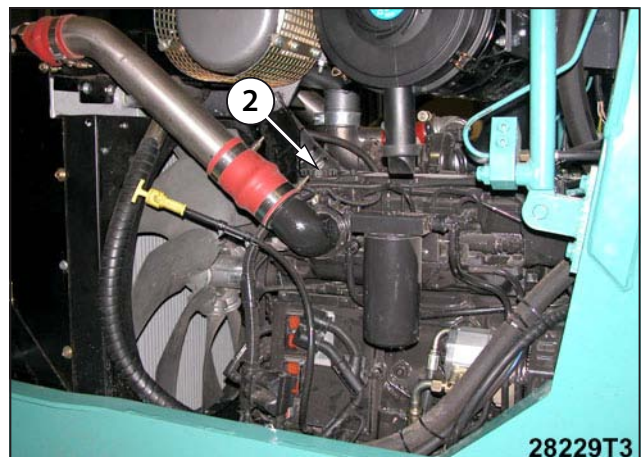

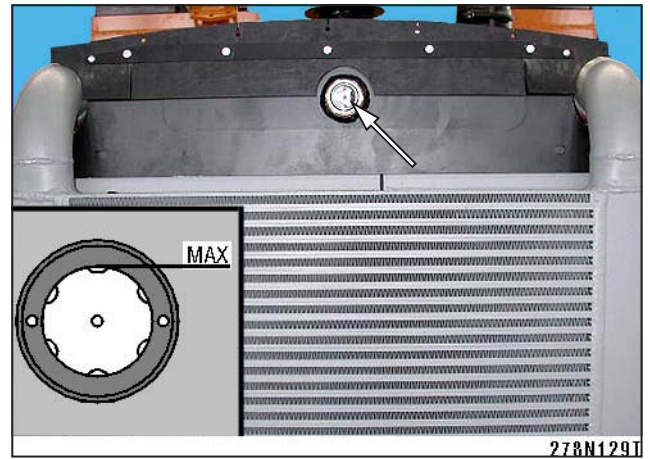

### 3.6.2. Engine cooling liquid level check

- Let cooling liquid cool down to less than 50 °C (120 °F).
- Check visually the level.

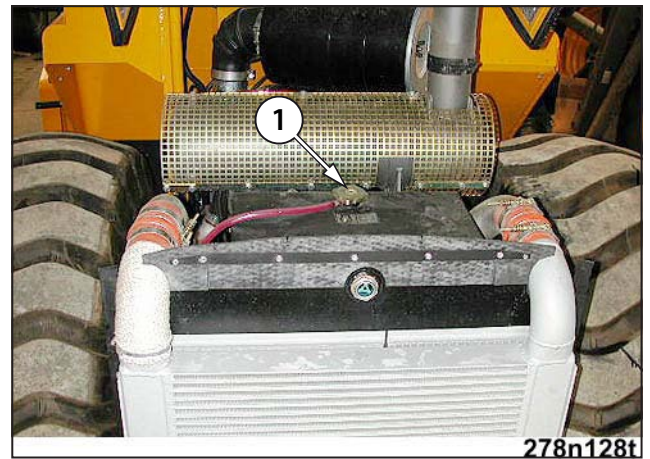

- Refill coolant through the filler 1.



 **Dismantle the filling plug only when the temperature of engine cooling liquid falls to less than 50 °C (120 °F). If you open it at higher temperatures, you risk scalding by steam or by cooling liquid due to the inner overpressure.**

 **The level must not fall below the level indicator eyesight.**  
**Refill only cooling liquids containing the frost-resistant agents on the identical basis, according to chapter 3.2.3.**  
**Do not add additives eliminating un-tightness of the cooling system to the engine cooling liquid!**  
**Do not refill cold cooling liquid into hot engine. Engine castings might get damaged.**  
**In case of larger losses, find the location of cooling system leaks and repair the cause.**

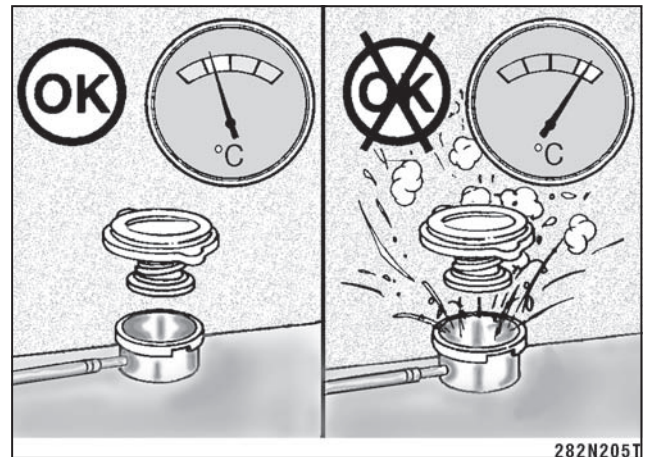

## 3.6. Individual Operations of Maintenance

### 3.6.3. Hydraulic tank oil level check

- Check and maintain oil level. Indicator lamp will signal any oil loss below "STOP" (engine stops).

**Note:**

Engine can be started only after oil is filled up.

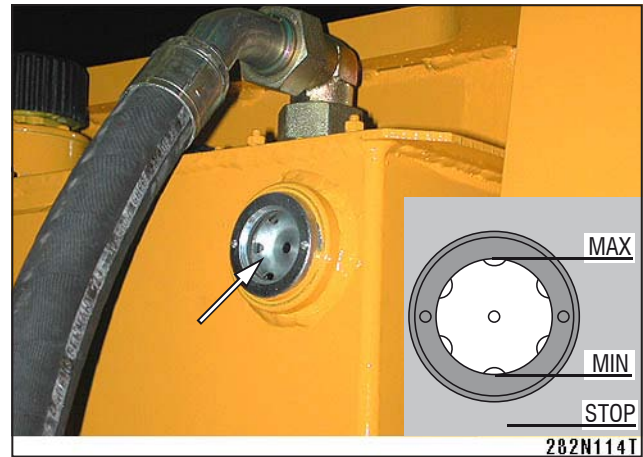

**! NOTE !**

**If the oil level falls below the lower edge of the "MIN" oil-level indicator, the engine will automatically stop and signal lamp will light up.**

**NOTE**

In case of more extensive losses find the location of hydraulic system leaks and repair the cause.

By stopping the engine in case of oil leakage, the hydraulic system of the machine is protected and operation is environment-friendly, since in case of hydraulic hose damage not all the content of the hydraulic tank but only limited amount would leak out. The engine can only be started after refilling oil.

### 3.6.4. Crankcase breather tube

- Check crankcase bleeding pipe to avoid its contamination with deposits.



**3.6.5. Check of the fan and engine belt condition**

- Check the ventilator visually. In case of any damage (e.g. missing parts of the material, cracks, changes in shape etc.) replace the ventilator.

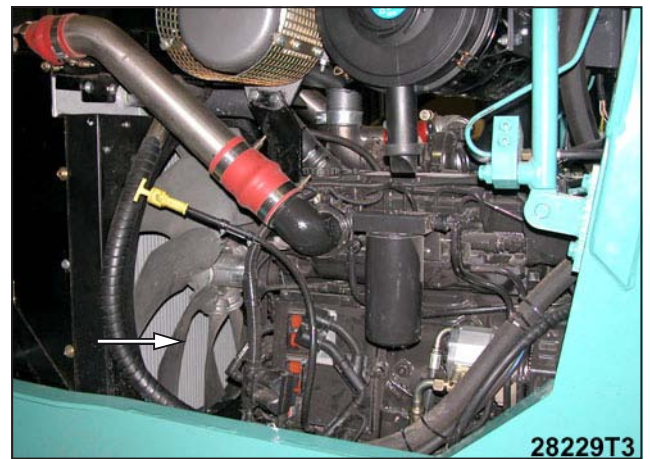

- Check visually the belt for its deterioration.

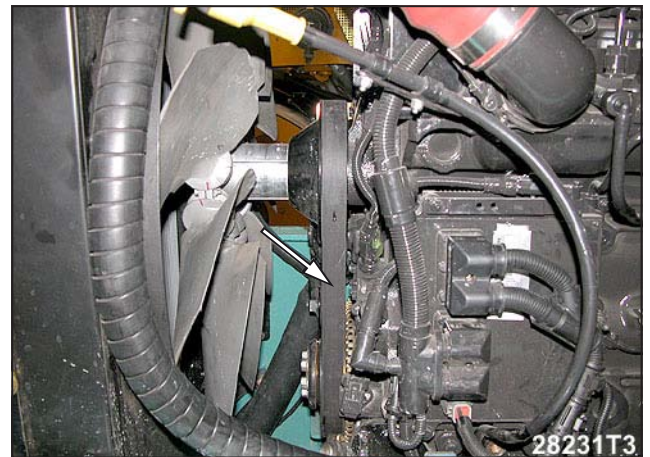

- Traverse (across the belt width) cracks are acceptable. Longitudinal (direction of belt length) cracks that intersect with traverse cracks are not acceptable. Replace the belt if it is frayed or has pieces of material missing.

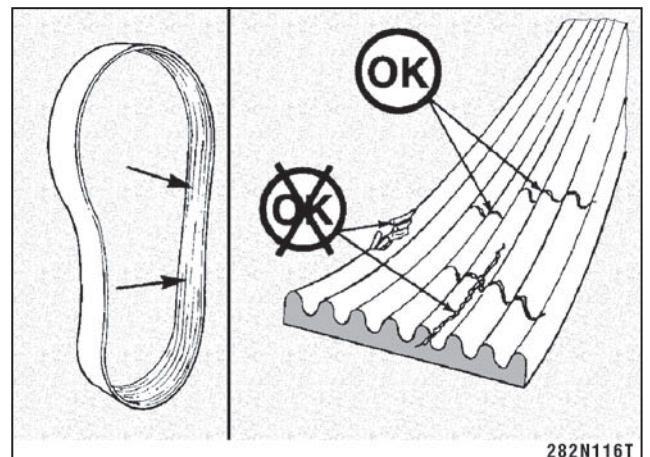

## 3.6. Individual Operations of Maintenance

### 3.6.6. Checking the vacuum valve of the air cleaner

- Clean the exit slit and remove the trapped dust by pushing.

#### NOTE

- Collected dust is stored in the dust valve and automatically emptied during the machine operation.



**Do not operate the machine if the dust valve is damaged.**

- Check and clean up the pre-filter tray 1 when any contamination deposited reaches the mark, first unscrew the nut 2 and remove lid 3.

#### NOTE:

Pre-filter is optional and is mounted based on separate order only.



3.6.7. Checking warning and control devices

- Turn ON the switches, test if horn, lights and direction indicators lights work. Turn ON the ignition key to position I, check brake pilot lamps for brake, neutral, and for recharging. ROPS2D indicator lamp will light up shortly along with warning alarm heard.

 **If ROPS2D indicator lamp continues to flicker, carry out troubleshooting.**

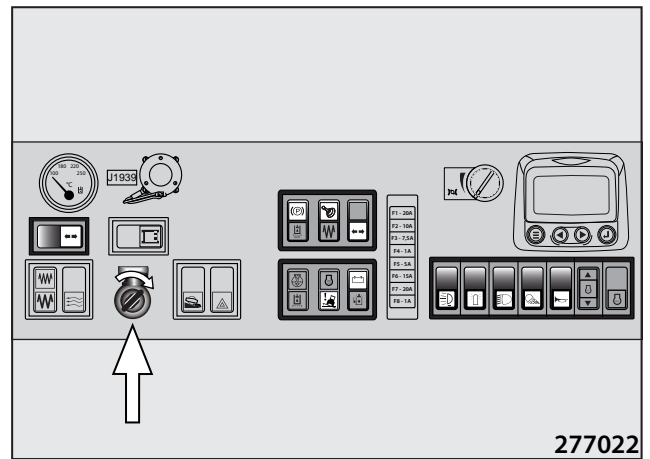

- Start the engine, press TOTAL STOP - engine stalling must occur, pilot lamps go ON.

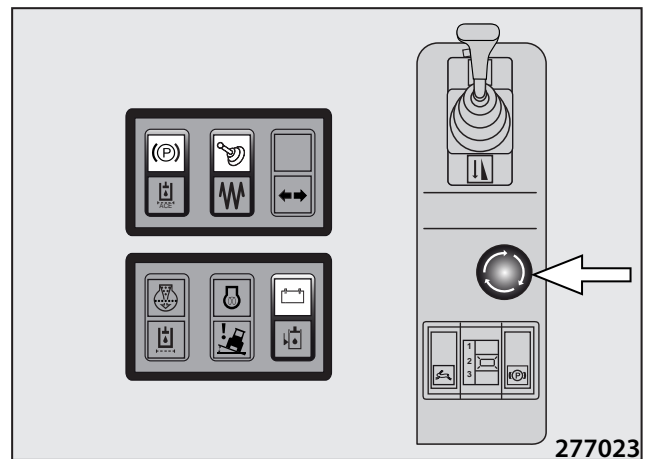

## 3.6. Individual Operations of Maintenance

---

After 100 hours of operation (weekly)

### 3.6.8. Checking the tyre pressure

**! NOTE !**

**Rotate tyres so that valves are at top positions.**

- Check the pressure in cold tyres, by air pressure meter.
- Keep the tyre pressure at 160 kPa (23.2 PSI).



After 250 hours of operation (3 months)

3.6.9. Checking the engine inlet piping

- Check the tightness of engine inlet piping.
- Check for any damage of the rubber hose of the inlet piping leading from the filter, and for missing clamping clips.

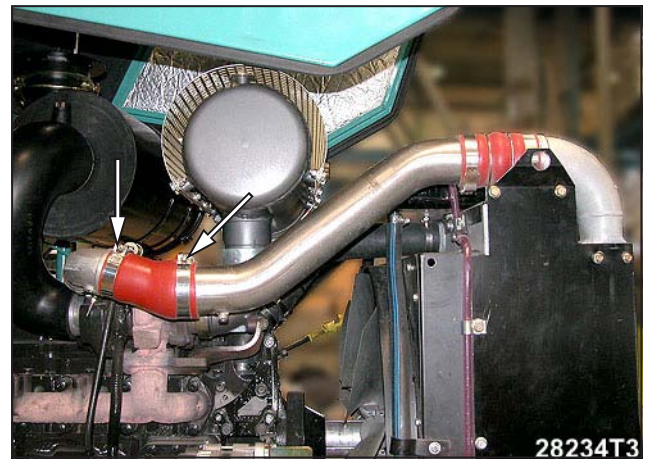
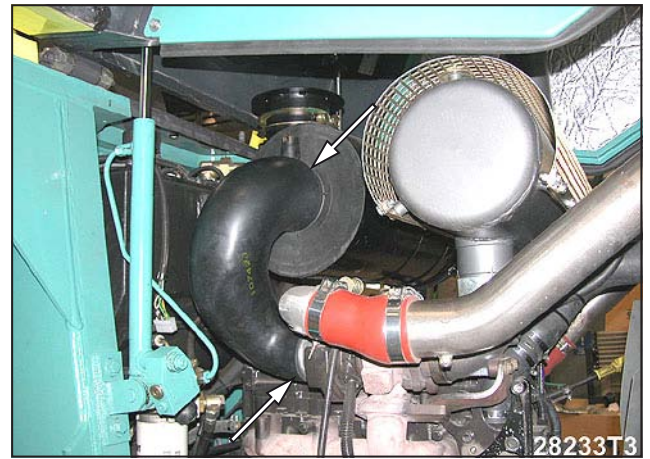

- Check again tightness between the bonnet 2 and the air cleaner 3.
- Replace damaged sealing 1 with a new one.

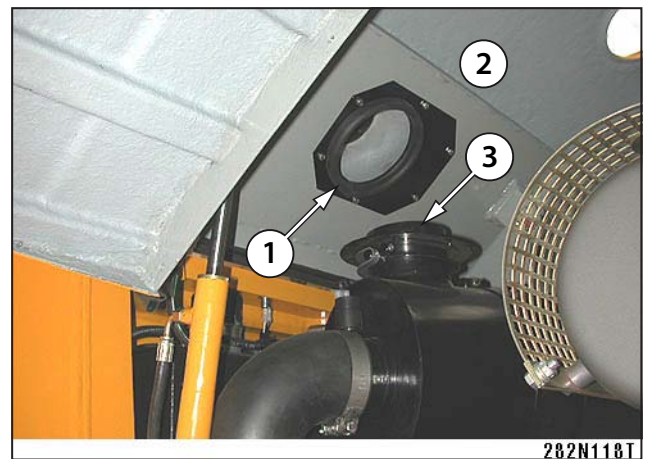

**Do not operate the machine if the sealing between the bonnet 2 and the air cleaner is damaged or not tight.**

## 3.6. Individual Operations of Maintenance

### 3.6.10. Check of the fan and engine belt condition

- Check the ventilator visually. In case of any damage (e.g. missing parts of the material, cracks, changes in shape etc.) replace the ventilator.
- Lift the belt-tensioning pulley using the lever and remove the belt.
- Check visually the belt, for intersecting cracks. Traverse (across the belt width) cracks are acceptable. Longitudinal (direction of belt length) cracks that intersect with traverse cracks are not acceptable. Replace the belt if it is frayed or has pieces of material missing.

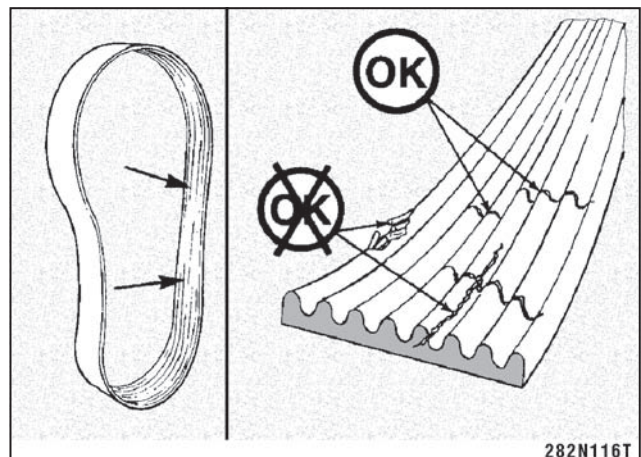
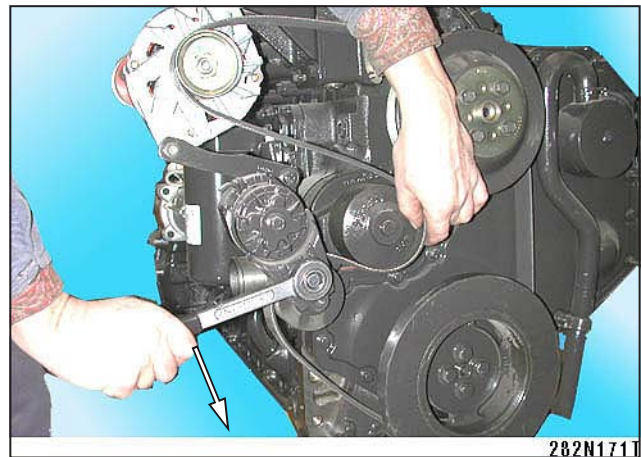
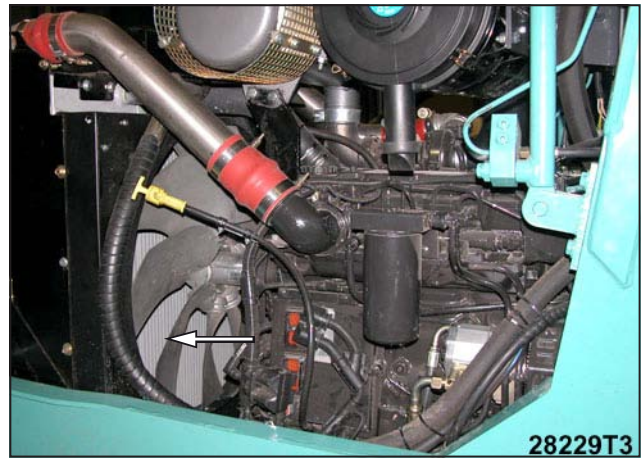

**3.6.11. Check of coolers**

- Check tightness of the cooling circuit. Check the circuit for damaged hoses and for missing hose clips.

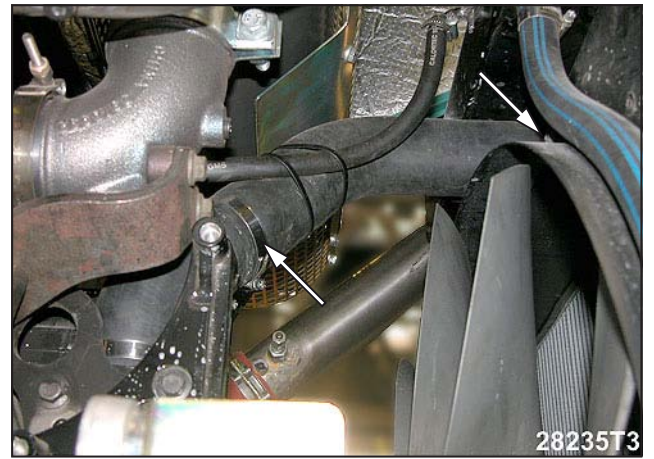

- Check whether the oil cooler gills and the engine radiator gills are not clogged. In case of clogged gills clean them for instance by blowing the radiators through with pressure air (steam or warm water).

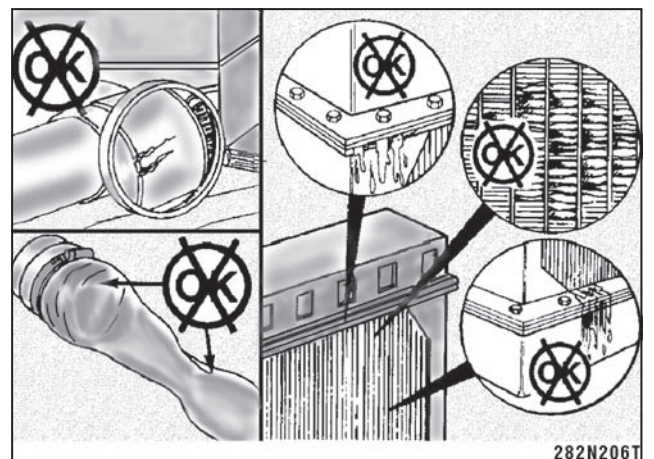
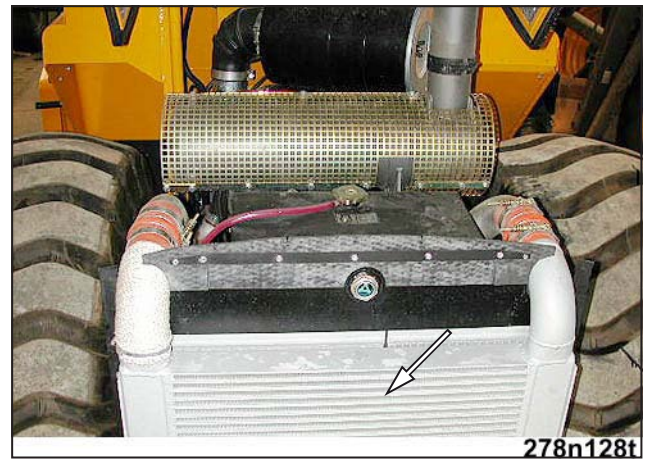

## 3.6. Individual Operations of Maintenance

### 3.6.12. Battery check

- Place the roller onto flat, firm surface.
- Stop the engine and disconnect the electric system using the isolating master switch.
- Clean the surface of batteries.
- Check the condition of poles and terminals 1 and clean them. Slightly wipe terminals with grease.
- Check the level of electrolyte after opening plugs of the battery cells 2 - the level of electrolyte in all cells should be 5 - 15 mm (0.2-0.6 in) above the plates, or to the lower edge of the gauge in the battery cells. Refill the cells whose electrolyte level is lower, than 5 mm (0.2 in) above the plates, with distilled water.
- Measure electrolyte density in the individual cells using a refractometer

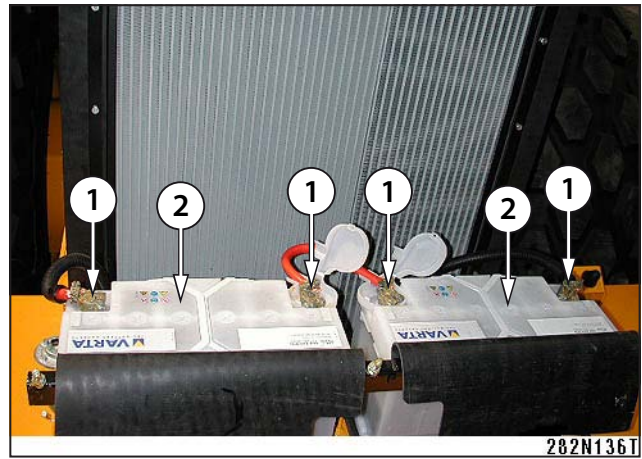

282N136T

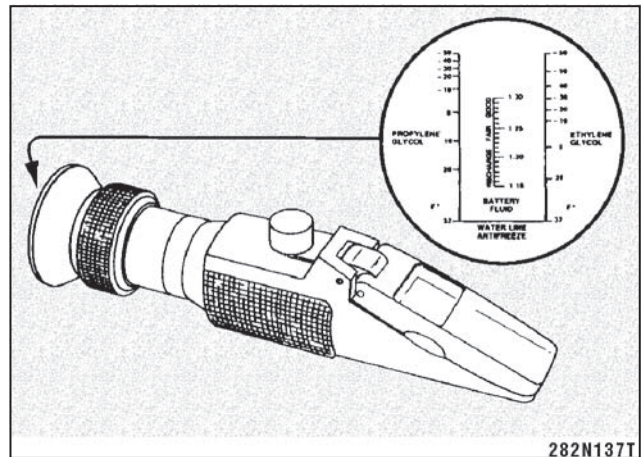

282N137T

or hydrometer.

- Compare measured values with the chart.

	Density			
	in g/cm <sup>3</sup>		in °Be (Beume)	
	20 °C 68 °F	Tropics	20 °C 68 °F	Tropics
fully charged	1,28	1,23	32°	27°
semi charged	1,2	1,12	24°	16°
exhausted – charge immediately	1,12	1,08	16°	11°



282N138T

#### NOTE

- Check the level using a glass tube.
- Should the machine not be used during winter period - for couple of weeks, dismantle the batteries and store them away from frosts. Check batteries and charge level before and during storage.



**Use protective gloves and eye protection equipment when working with the battery.**

**Wear suitable dress to protect your skin against staining with electrolyte.**

**In case of an eye injured by electrolyte immediately wash the eye with flowing water for couple of minutes. Then seek medical advice.**

**In case of ingestion of electrolyte drink maximum possible amount of milk, water or mixture of magnesium oxide with water.**

**In case of staining your skin with electrolyte take off your clothes and shoes, wash injured spots with soap water or with solution of soda and water as soon as possible. Then seek medical advice.**

**Do not eat, drink and smoke during operation!**

**Wash your hands and face carefully with soap and water after finishing you work!**

**Do not test whether wires are alive by touching the frame of the machine.**

**In case of contact of both poles of the battery the short-circuit may cause explosion of the battery.**



**Do not turn batteries upside down to avoid draining of electrolyte from venting of the battery.**

**In case of spilling electrolyte wash such a place with water and neutralise with lime.**

**Dispose of old damaged batteries.**

**! NOTE !**

**If a maintenance-free battery is installed on the machine, it is not necessary to check the electrolyte level and the electrolyte is not filled up for the whole service life of the battery. Other tasks prescribed above must be performed. Consult the battery discharge condition – the lowest permissible voltage level (measures on the battery terminals) under which the battery could be damaged and the charging procedure with the manufacturer.**



**Keep the batteries dry and clean.**

**Close batteries after checking.**

**Refill battery with distilled water only - never with acid.**

**Refill distilled water immediately before working with the machine or before recharging the battery.**

**Recharge insufficiently charged battery.**

**Recharge batteries dismantled from the machine.**

**Open the plugs before recharging.**

**Do not disconnect the battery under running engine.**

**Always follow the instructions of the manufacturer, when working with the battery.**

**Disconnect the battery to avoid short-circuit when repairing it or manipulating with wires and electric equipment in the circuit of electric system.**

**Disconnect the minus pole wire first when disconnecting the battery. Connect the plus pole wire first when connecting the battery.**

## 3.6. Individual Operations of Maintenance

### 3.6.13. Air filter sensor check

- Remove engine induction cover.

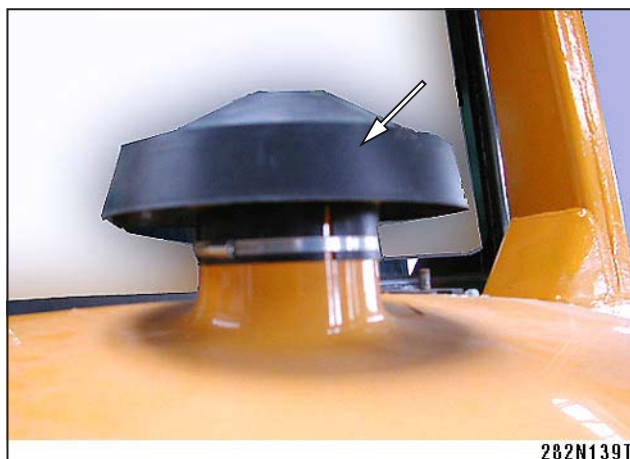

- Cover the air filter suction hole on the engine bonnet.

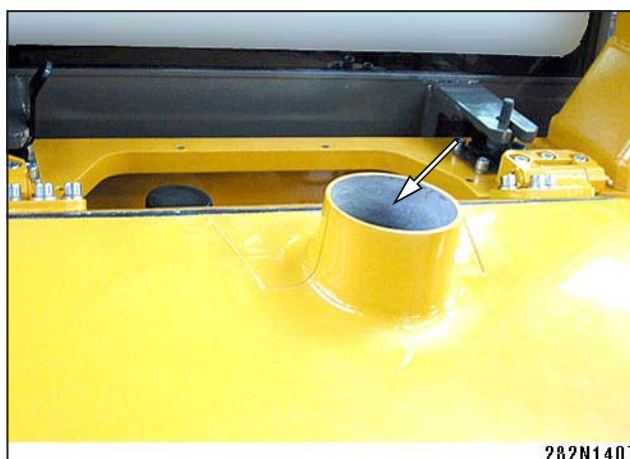

- Start the engine and increase its speed by turning OFF the IDLE switch. Check the filter-fouled indicator lamp goes ON.

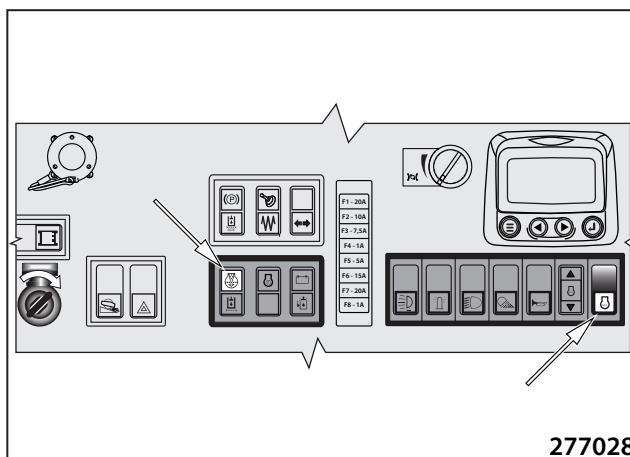

- Unless it lights, check the following: vacuum switch, bulb inside indicator lamp, contact, feeder cable.



**3.6.14. Lubrication of the machine**

- Remove the caps on the grease nipples.
- Successively mount the grease nipple of pressure lubricator and continue greasing until the old grease starts to drain out.
- Return the grease nipple caps.

**Steering**

upper bearing, lower bearing

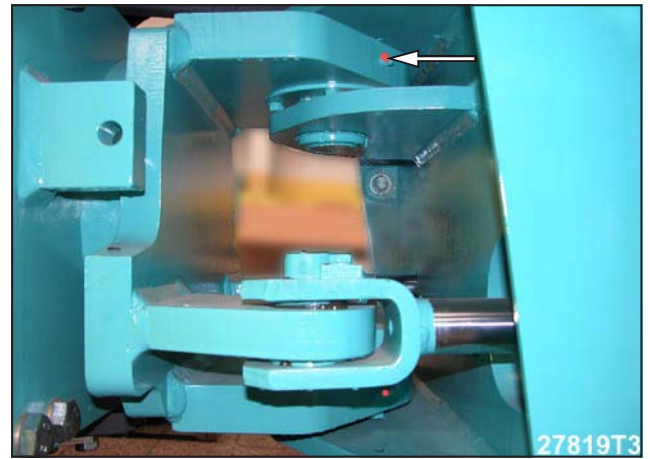

bearing 4x



**Steering hydraulic cylinders**

front pins 2x

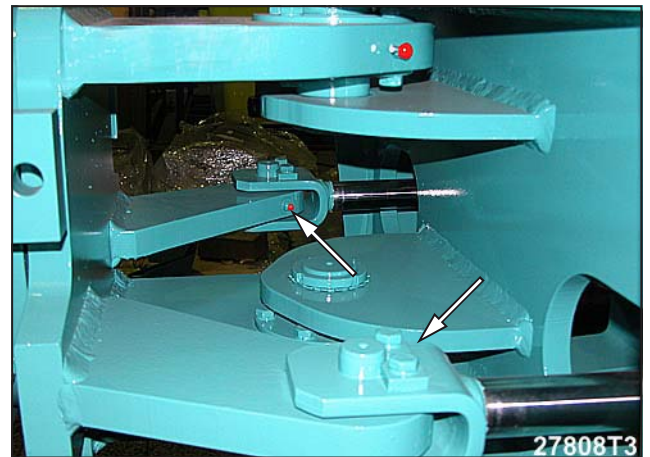

rear pins 2x



### 3.6. Individual Operations of Maintenance

#### Hydraulic cylinders of bonnet lifting

upper pins 2x



lower pins 2x



#### Hydraulic cylinder of driver's post lifting

lower pins 2x



#### Door hinges pins

pins 6 x



**Bonnet hinges pins**

pins 2 x

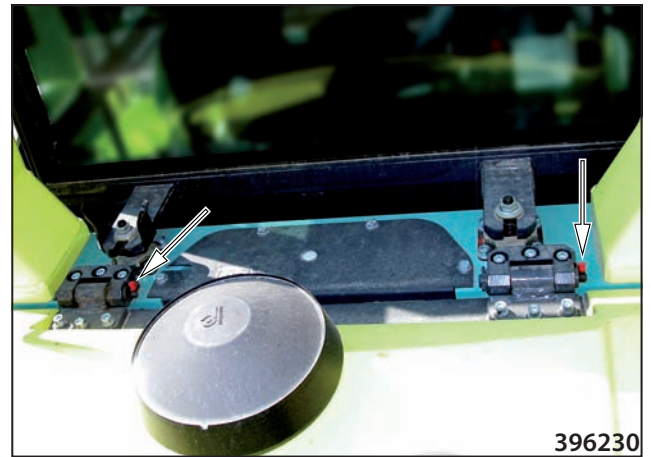

**Front pins of cabin attachment**

pins 2 x



**Use only recommended lubricating greases, see chapter 3.2.6.**

## 3.6. Individual Operations of Maintenance

### 3.6.15. Checking oil in the vibrator

- Stop the machine on an even firm surface in order that the plugs on the left side of the drum are in the position according to fig.
- Clean the area around the checking plug 1.
- Unscrew the plug 1 and check the oil level. The oil level must reach the checking opening or slightly flow out.
- Refill oil after unscrewing filling plug 2.
- Clean the plugs and mount again.

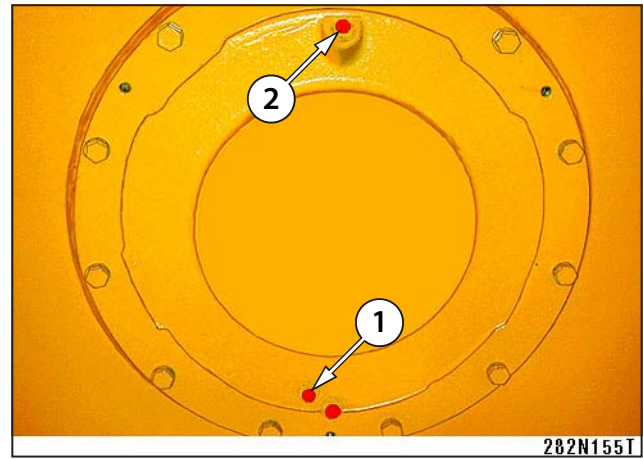

**Check oil when it is cooled down.  
Refill the identical type of oil.**



**Avoid leakage of oil to the soil.**

### 3.6.16. Checking oil in gearboxes

#### Axle gearbox

- Stop the machine on even, firm surface in order that the gearbox plugs of both wheels are in the position according to fig.
- Clean the area around the checking plug 1.
- Unscrew the plug 1 and check the oil level. The oil level must reach the checking opening or slightly flow out.
- Refill oil through the filling plug 2, if necessary.
- Clean the plugs and mount again.

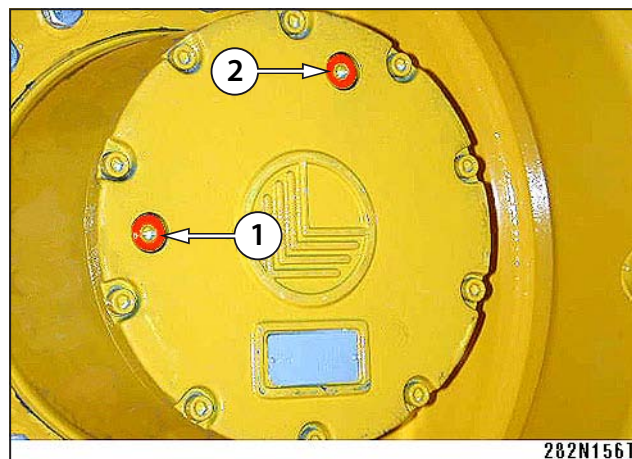

282N156T

#### Drum gearbox

- Clean the area around the checking plug 1.
- Unscrew the plug 1 and check the oil level. The oil level must reach the checking opening or slightly flow out.

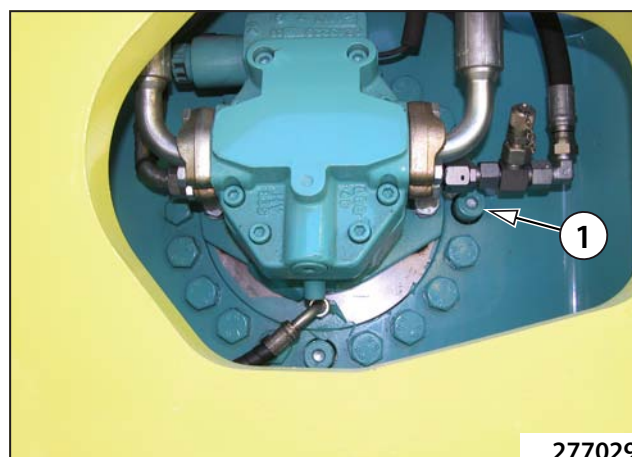

277029

- After disassembly the cover 1.

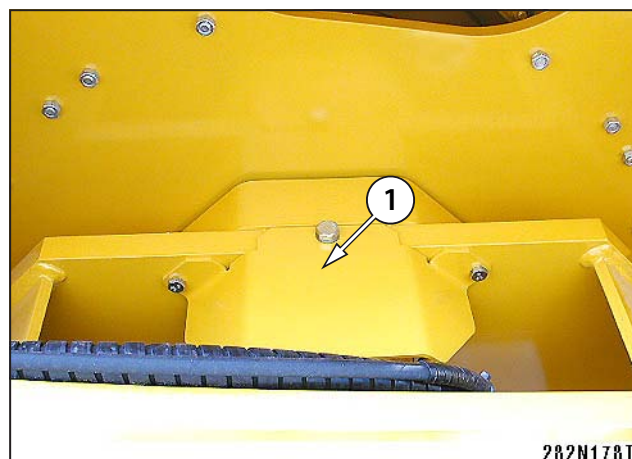

282N178T

- Refill oil through the filling plug 2, if necessary.
- Clean the plugs and mount again.
- Check tightness of the gearboxes.



**Do not touch the gearbox and adjacent parts if they are hot.**

**! NOTE !**

**The plugs are located on the static part of the gearbox - they do not rotate during driving.**

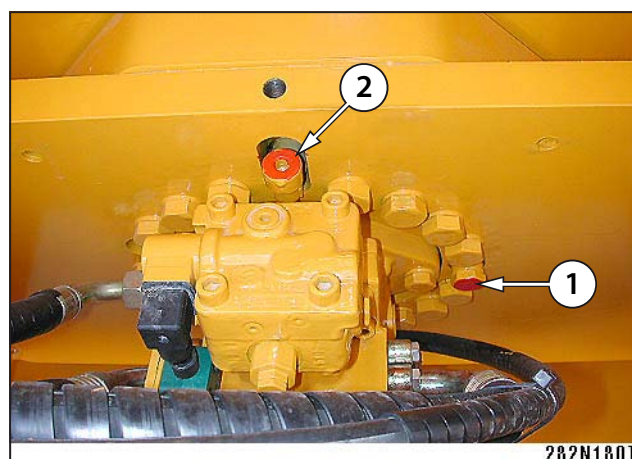

282N180T

## 3.6. Individual Operations of Maintenance

---

### 3.6.17. Inspect the pad foot segments

Before inspection is made, clean the segment surface, and mainly round bolted connections. Check overall condition of the segments (any fissures, deformations) and whether M20 8G bolts are tightened with 390 Nm (287,6 lb ft) torque.



After 500 hours of operation (after 6 months)

3.6.18. Replacing oil in the engine



Drain the oil after stopping the operation immediately, when is temperature of cooling liquid 60 °C (140 °F). Alternatively, operate the engine until the cooling liquid temperature reaches 60 °C (140 °F).

- Prepare a suitable container with the capacity of approximately 20 l (21 qt).
- Dismantle the drain plug 1 and let oil drain.
- Mount the plug back.



- Clean the area around the oil filter head. Dismantle the filter 1. Clean the contact area of the filter sealing.

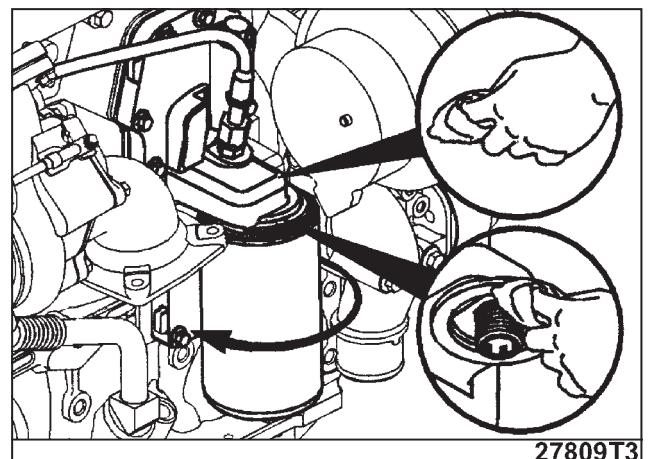
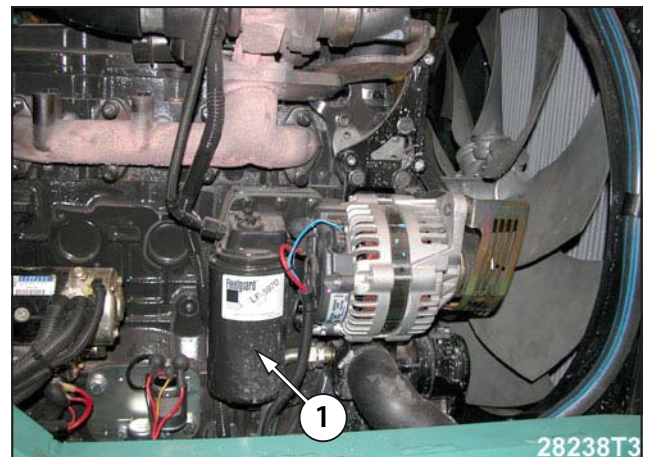

### 3.6. Individual Operations of Maintenance

- Take a new filter and fill it with clean engine oil.



- Wipe the sealing with oil.

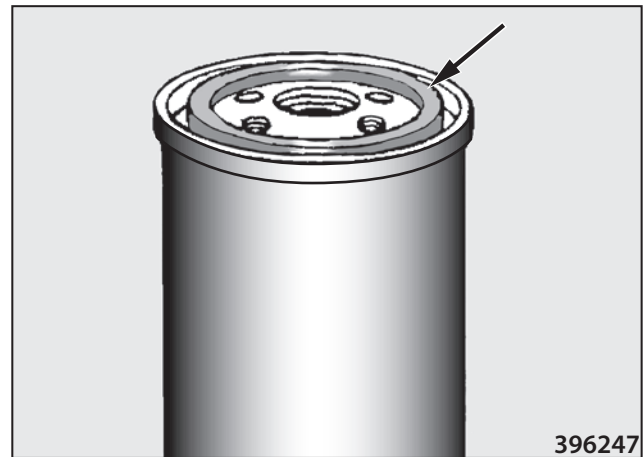

- Tighten 3/4 to 1 turn after gasket makes contact with the filter head.



**Do not tighten the filter too tight, the thread and sealing might get damaged.**

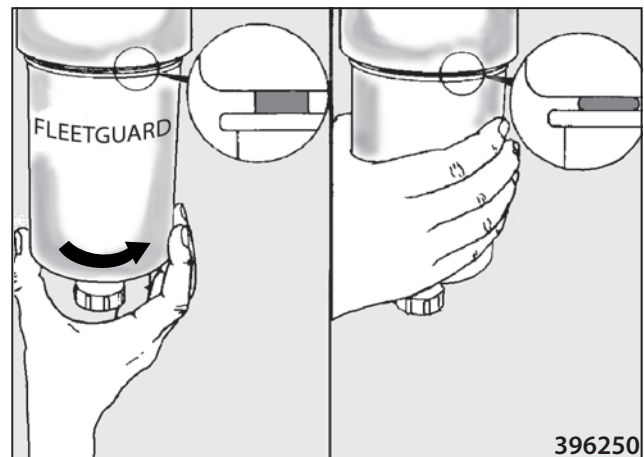

- Fill the engine through the filler 1.

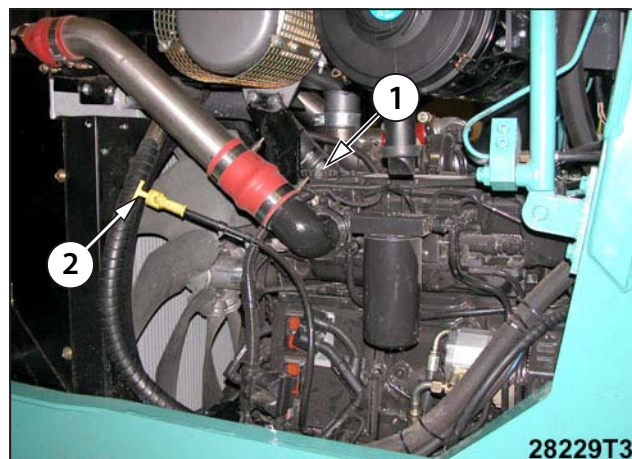

- Refill oil to the upper oil level mark 2. Oil charge is 11 l (12 qt) inclusive of fill oil filter.

**NOTE**

- After refilling, start the engine for 2 - 3 min. Check tightness of drain plug and filter.
- Stop the engine, wait for approx. 5 min. until oil runs down to the engine sump. Then check the level with oil dipstick.



**Beware of scalding when draining hot oil. Let oil cool down to less than 50 °C (122 °F).**

**Follow the fire safety measures!**



**Exchange oil after 6 months at the latest, if 500 hours of operation have not been reached by that time. Exchange oil in the interval that comes first.**

**Use recommended filters - see Spare parts catalogue. Use recommended oil - see chapter 3.2.1.**



**Collect drained oil; do not let it soak into the ground.**

**Used oil and filters are environmentally dangerous waste - have them liquidated.**

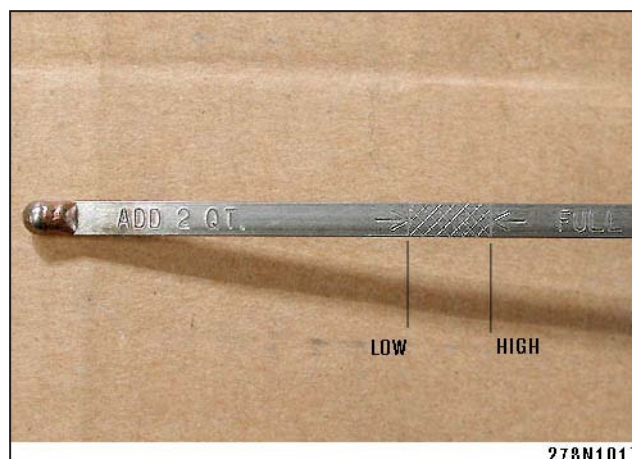

## 3.6. Individual Operations of Maintenance

### 3.6.19. Fuel filter replacement

#### Fuel filter

- Clean and remove fuel filter.

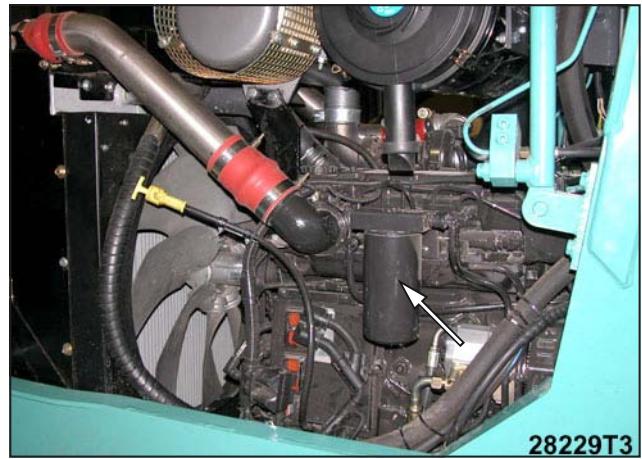

- Clean contact surface for the filter.



- Apply oil over the sealing ring at the new filter.

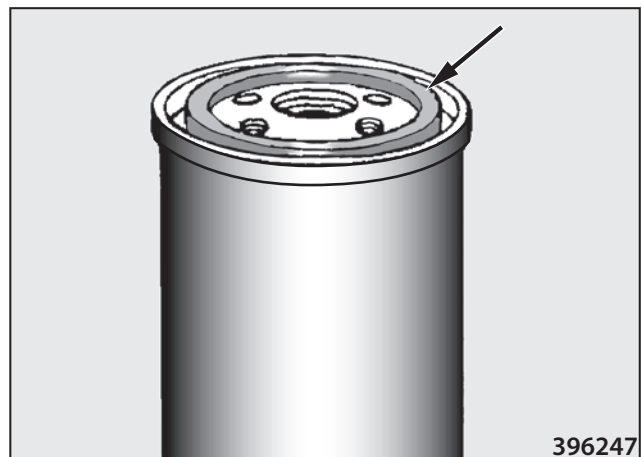

- Fill the filter with pure fuel.



- Install the filter and tighten with your hand - as per filter manufacturer's data (by 2/3 turn once the filter bears on).

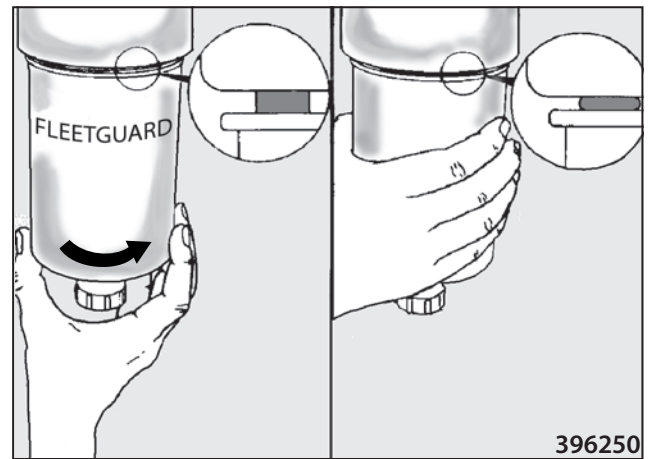

### Fuel pre-filter

- Disconnect the connector of water separator sensor and proceed in the same way like in the previous text. Connect the sensor connector.

### Note

- Unless filters are filled with fuels when exchanging them, please replenish fuel, refer to the Chapter named "**Clearing the water separator**".

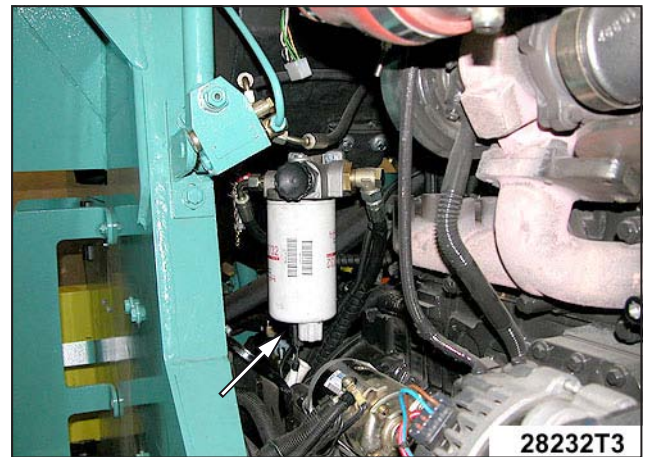

**Use original filters required.**  
**No smoking at work!**  
**Do NOT tighten the filters with force.**



**Retain any fuel flowing out.**  
**Store used filters inside separate container, and hand over for their disposal.**

## 3.6. Individual Operations of Maintenance

### 3.6.20. Engine cooling liquid check

- Check the concentration of anti-freeze agent in cooling liquid using a refractometer.



**Check the cooling liquid always before winter season. In case the concentration measured is not sufficient for -36 °C (-34 °F), adjust it by adding frost-resistant agent into cooling liquid or exchange cooling liquid.**

- Add anti-freeze agent according to chapter 3.2.3.

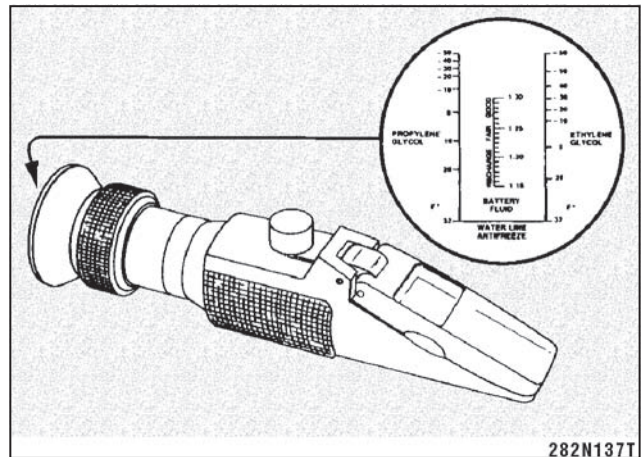

### 3.6.21. Checking tightening bolts of wheel

- Check tightening bolts of wheel using a torque wrench.
- Tightening torque is 165 Nm (122 lb ft).



After 1,000 hours of operation (after 1 year)

3.6.22. How to check tightening pulley and belt of the engine

- With the engine running inspect visually any vibrations of the fan pulley.



- Stop the engine!
- Confirm the stop of tensioner arm does NOT contact bump stop of the bush. Replace the belt if it makes a contact. When the arm stops continue to contact bump stop of the bush, replace the tensioner.



- Lift the belt tightening pulley using a lever with a square end of 10 mm (3/8 in) and remove the belt.

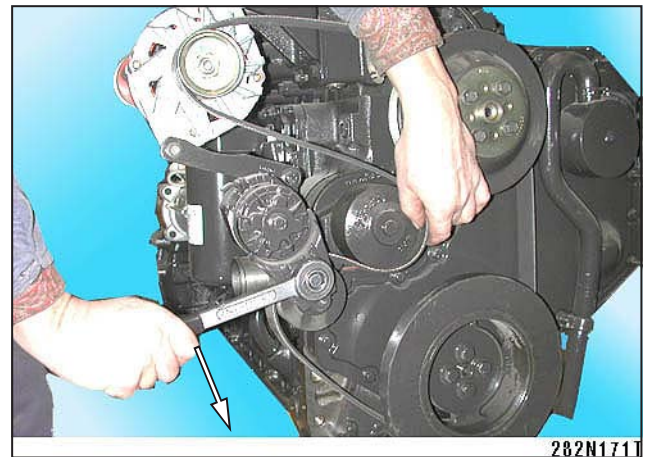

- With the belt removed, check to confirm the stop of the tensioner arm comes into contact with the bump stop of the bush. Unless so, replace the tensioner.

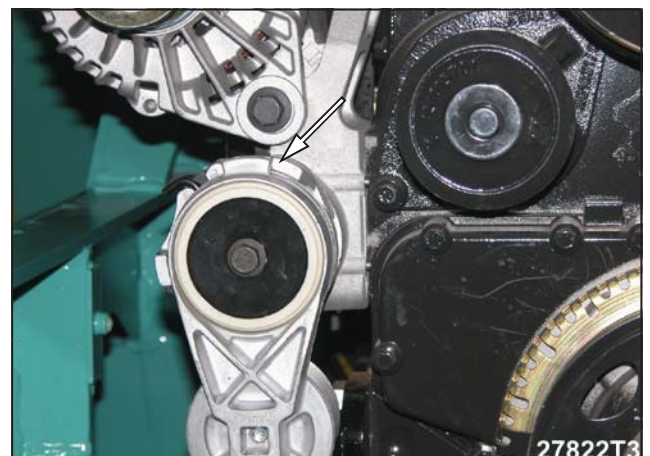

### 3.6. Individual Operations of Maintenance

- Check the pulley (arm) does not deflects from the vertical axis. Maximal deflection allowed is 3 mm (0.12 in). Inspect the tensioner pulley along with the arm to make sure there are no fissures over there.

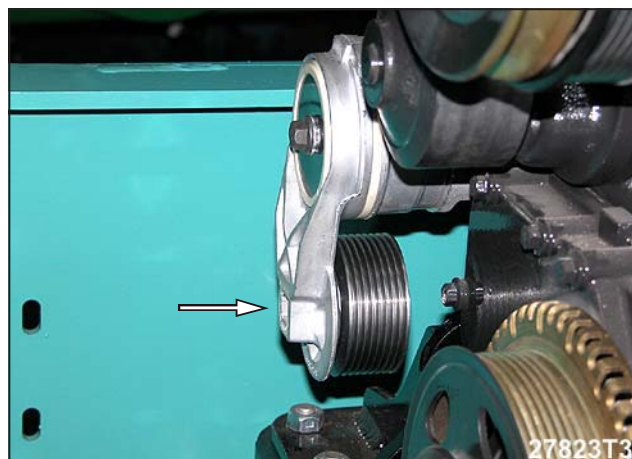

- Check axial clearance of fan pulley. This clearance may not exceed 0,15 mm (0.006 in).
- Reinstal the belt back.

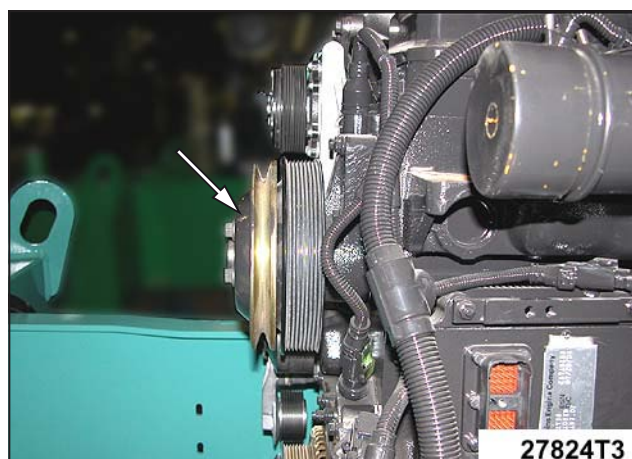

### 3.6.23. Oil exchange in the travel gearboxes

#### Axle (wheel) gearboxes

- Place the roller onto a flat, firm surface so that the axle gearbox plugs are in the position according to Fig. Clean the area around plugs. Put appropriate vessel under the drain plug 1. Unscrew both plugs and clean them and drain oil.

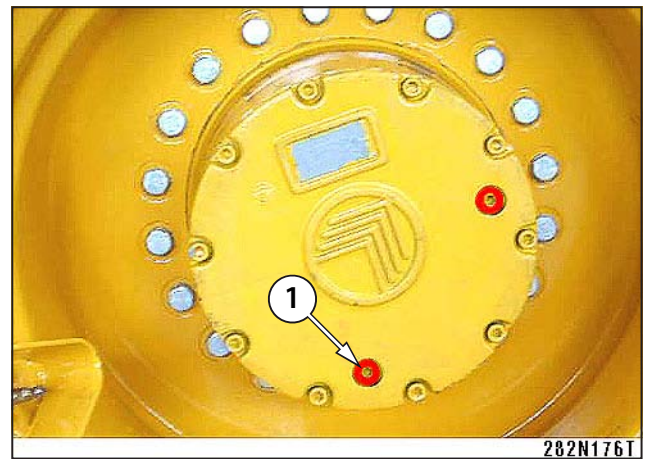

- After draining drive away with the roller so that the plugs turn to the position.
- Fill oil through the upper plug 2 until the level reaches the checking opening 1 or until it starts flowing out.
- Mount the plugs, replace damaged plug sealings.

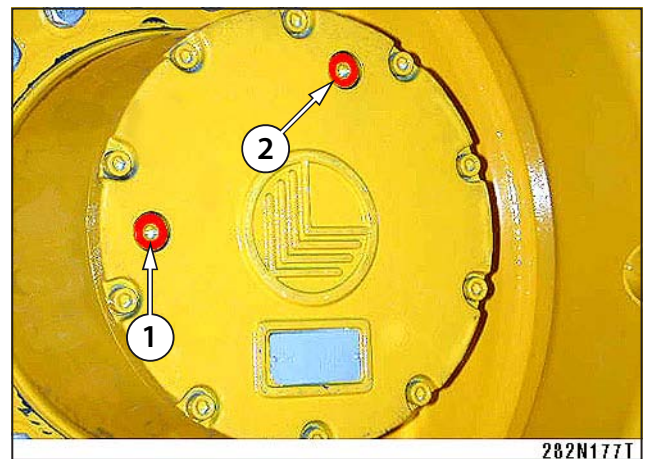

## 3.6. Individual Operations of Maintenance

### Drum gearbox - right side

- Place the roller onto a flat, firm surface.
- Unscrew cover.

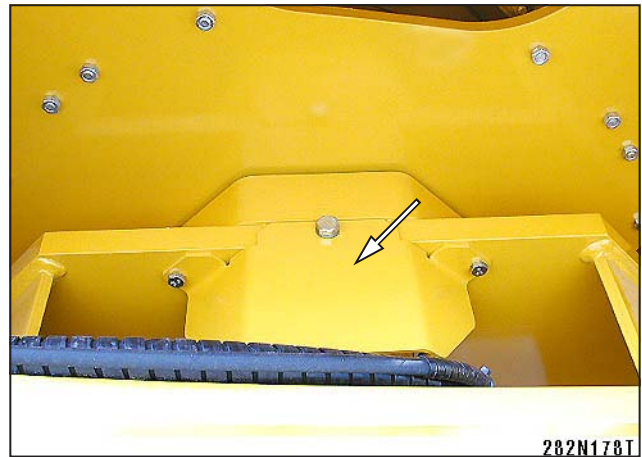

- Clean the area around plugs.
- Put appropriate vessel under the drain plug 3.

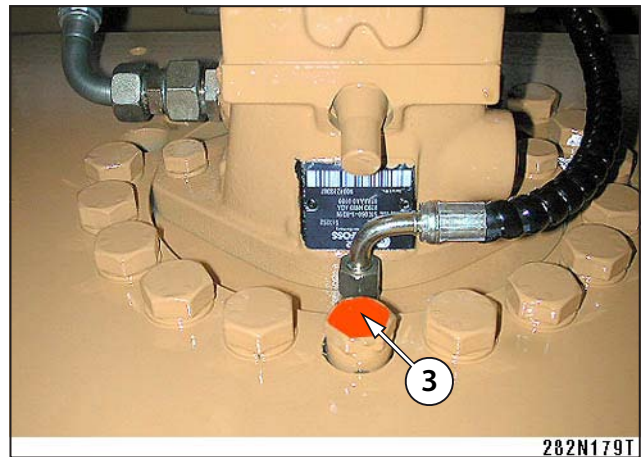

- Unscrew all plugs 1, 2, 3 and let oil drain.
- Mount the drain plug 3 after draining is finished.
- Refill recommended oil through the filling plug 1.
- Check oil level in the checking opening 2. The oil level must reach the lower edge of the opening or slightly flow out.
- Mount the plugs 1 and 2, replace damaged plug sealings.



**Do not touch the gearbox and adjacent parts if they are hot.**



**Perform the first oil exchange after reaching 100 operation hours.**

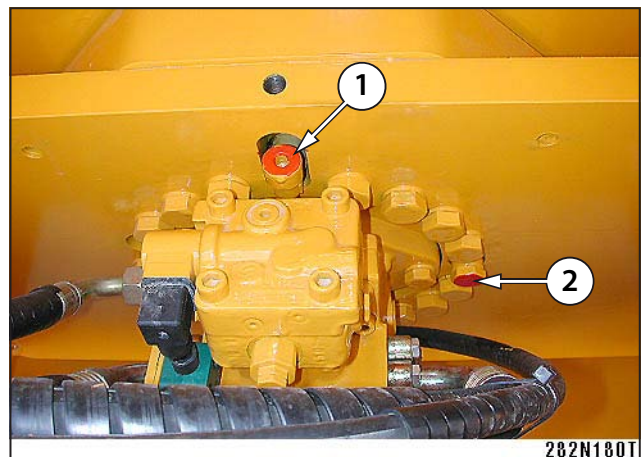

**3.6.24. Checking the damping system**

- Check the condition of metal-rubber mountings and bonding of metal with rubber.

Drum damping system - left side;

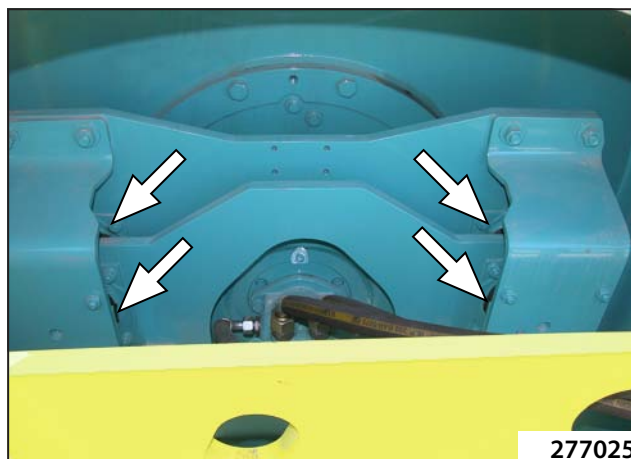

Drum damping system - right side;

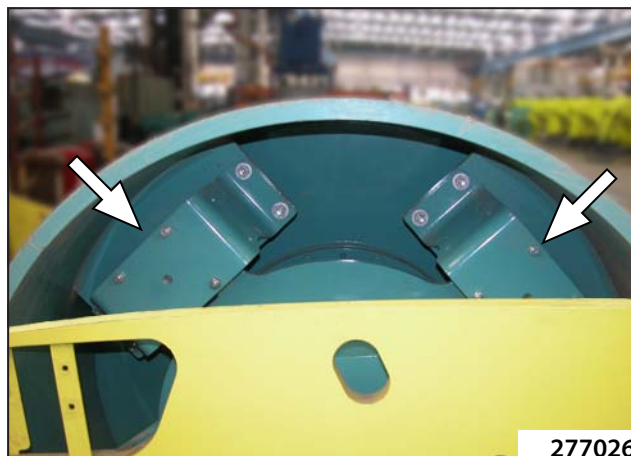

Front metal-rubber mountings - driver's post



Rear metal-rubber mountings - driver's post



### 3.6. Individual Operations of Maintenance

Front metal-rubber mountings of the engine

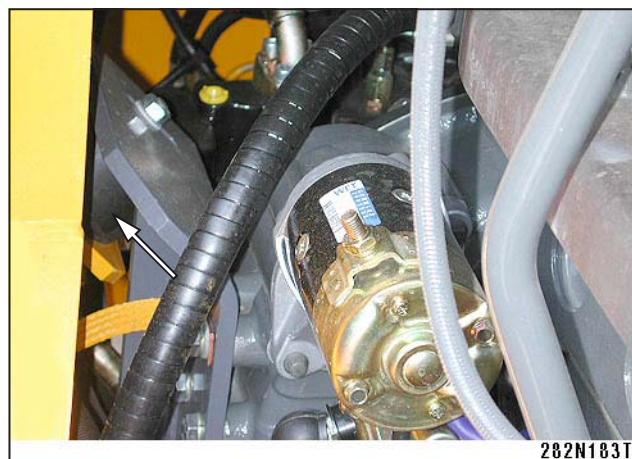

Rear metal-rubber mountings of the engine



- Replace damaged mountings.
- Check again tightening of bolts and nuts.

**After 2,000 hours of operation (after 2 years)**

**3.6.25. Checking, adjusting the valve clearance**

- Call CUMMINS service department to adjust the engine valves. Next valve adjustment will follow periodically after 2000 hours or after two years - for contact points, please refer to Engine Operation and Maintenance Manual.

**3.6.26. Oil exchange in the vibrator**

- Place the roller onto a flat, firm surface so that the drain plug on the left side of the drum 3 is in the lowest position and the opposite filling plug 1 in the highest position.
- Put appropriate vessel under the drain plug.
- Unscrew all plugs and let oil drain.
- Mount the drain plug after draining is finished.
- Refill recommended oil to the edge of the checking opening 2 through the filler 1.
- Mount remaining plugs.

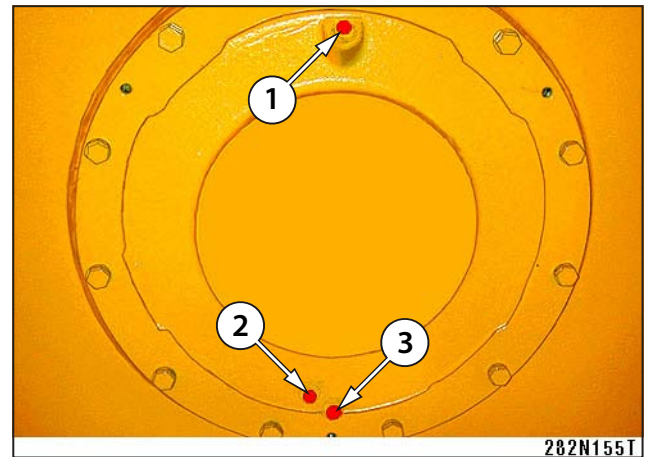

**! NOTE !**

**Change oil when it is warm.**



**Let drained oil cool down to less than 50 °C (122 °F).**



**Avoid leakage of oil to the soil.**

## 3.6. Individual Operations of Maintenance

### 3.6.27. Exchanging hydraulic oil and filter



Exchange oil before winter season starts or following a long term shutdown of the Machine. Clean the suction strainer at the same time, refer to par. 3.6.28.

- Fit the hose to the drain cock. Let oil drain into a prepared vessel - the total amount of oil is approximately 73 l (19.3 US gal).



- Dismantle the cover.



- Dismantle suction hose.

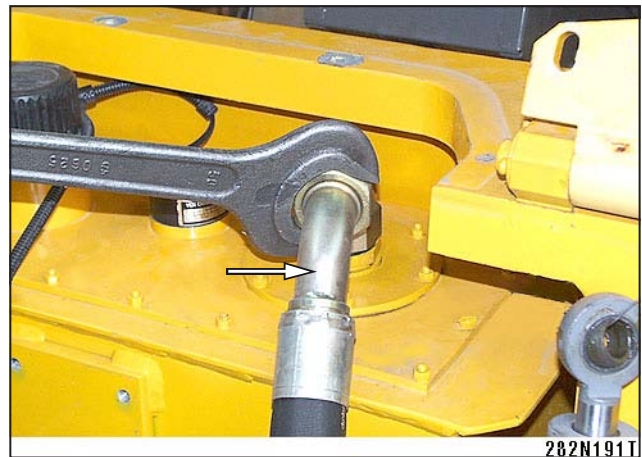

- Dismantle cover with suction strainer. Dismantle the suction strainer from the suction pipe. Wash the suction strainer and blow the strainer with pressure air from inside. Check the condition of the suction strainer; replace the strainer in case of damaged filter part. Check the inside of the tank. Carefully clean the bottom and flush it with new oil if there are any impurities on the bottom. Reassemble and wipe the "O" ring with clean oil.



For easier cleaning it is possible to dismantle the whole upper cover 1 with the filler. If you dismantled the whole upper cover, use a new teflon sealing strip.



**Drain oil after it has cooled down below 50 °C (122 °F).  
Follow the fire safety measures!**



**After disconnecting the hydraulic circuits blind all holes with plugs.  
Collect drained oil; do not leave it soak into the soil.  
Used oil is environmentally dangerous waste - have them liquidated.**

### Checking the oil thermometer sensor

- Dismantle the sensor and clean the contact.
- Dip the sensor into warm oil of known temperature and read out the oil temperature on the thermometer. Replace the sensor if not working properly.

### Filling the hydraulic circuit:

- Use a filling device with the following parameters:  
min. pressure 6 MPa (870 PSI)  
filtering property 3 to 10 µm
- Open the cover on the right side under the cabin and remove the cap of filling terminal.
- Mount the quick coupling of the filling device to the quick coupling. Fill the hydraulic circuit until clean oil starts to flow out of the hose. Collect it to a clean vessel.

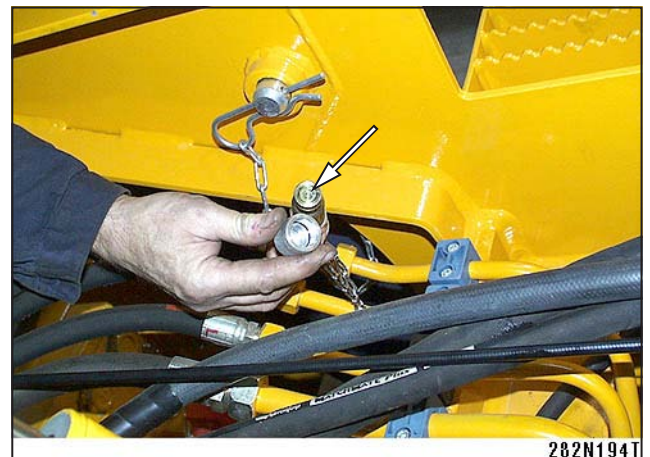
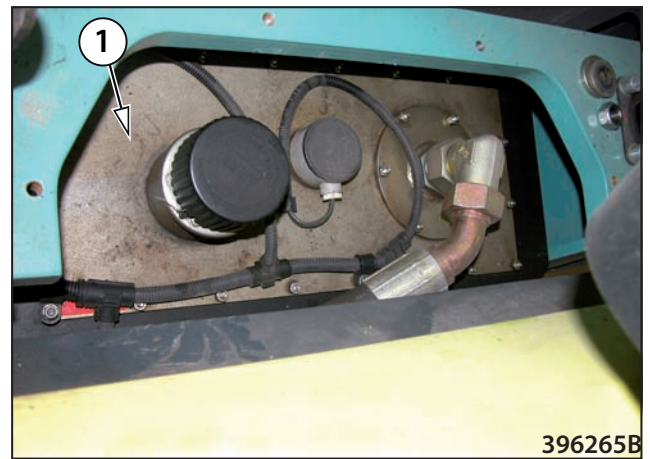

## 3.6. Individual Operations of Maintenance

- After flowing out of approximately 15 l (4 US gal), close the drain cock.

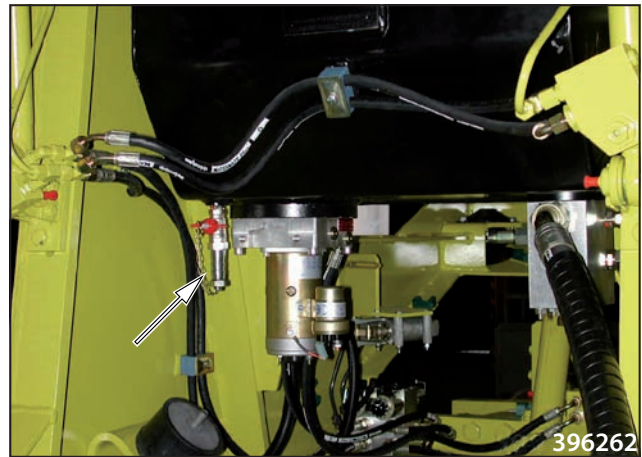

- Refill oil in the tank to maximum and disconnect the filling device.

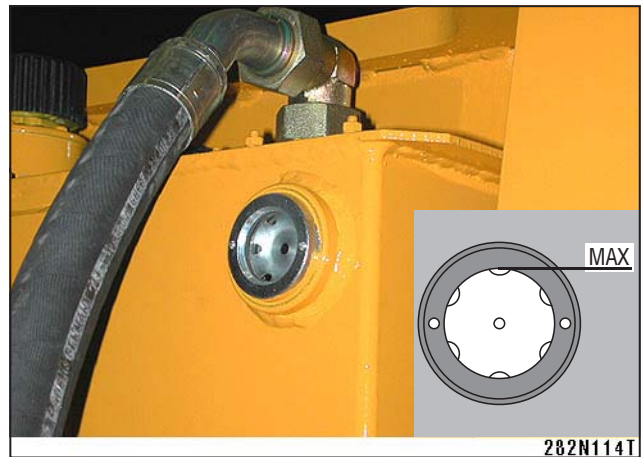

### Alternative filling through the tank filler



**The alternative way of filling the hydraulic circuit is only emergency solution!**

**In this way of filling it is necessary to cut the next exchange interval to one half, i.e. 1000 h or 1 year.**

**The cap of the tank filler is sealed. In case of breaking the seal during warranty period, the warranty expires.**

- Refill the tank through the filler with specified type of oil up to the bottom of the strainer in the filler.

#### NOTE

- When filling via tank filler neck a large portion of used oil incl. dirt will remain within the vicinity, and hydraulic units' life cycle will lower.
- Order your filling device from your Machine manufacturer or dealer.





**Observe cleanliness at work. Avoid contamination of the system with materials that may cause damage to crucial units!**  
**Do NOT open hydraulic tank uselessly!**  
**When cleaning the tank, use cleaners with no fibre-slip, do not use chemical detergents.**  
**Refill oil according to par. 3.2.4.**

### Exchanging the filter element of pressure filter

**! NOTE !**

**Exchange the filter element always in the following occasions:**

- **when changing oil**
- **if the signal lamp of pressure filter lights up after the working temperature reached 50 through 60 °C (122 - 140 °F).**

- Remove the filter. Clean from below the following: contact surface of the filtration block, spread pure oil over the new filter's ring, screw down, tighten.



**Use original filter elements according to spare parts catalogue only.**  
**Exchange oil and filter always when a destruction of internal parts of the units occurs (of hydromotors, of hydrogenerators), or during a major overhaul of the hydraulic system. Clean and rinse out the hydraulic tank before installing new unit, and fill it with oil. With the engine running at increased speed, please test the functions of the Machine. Check the tightness.**



**Used filter elements are environmentally dangerous waste - have them liquidated.**

## 3.6. Individual Operations of Maintenance

### 3.6.28. Cab and bonnet raising and lowering suction strainer unit cleaning

**! NOTE !**

**Clean the strainer when exchanging hydraulic oil.**

- Unscrew bolts 1, take out the unit from the bottom of the tank.
- Remove the suction strainer 4. Wash the suction strainer in petrol and blow through the strainer with pressure air. Check the sealing ring 5.



**Avoid leakage of oil to the soil!**

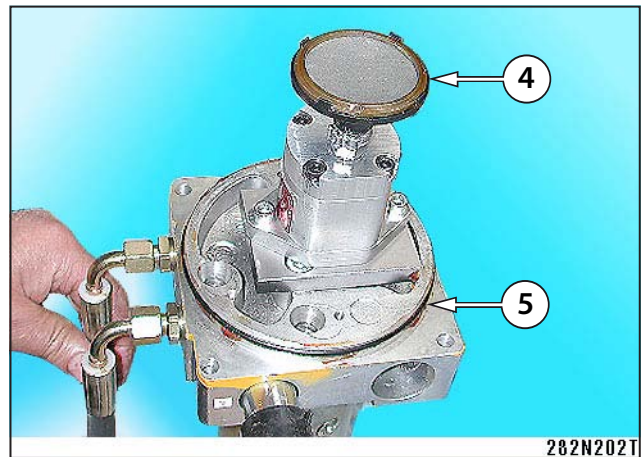
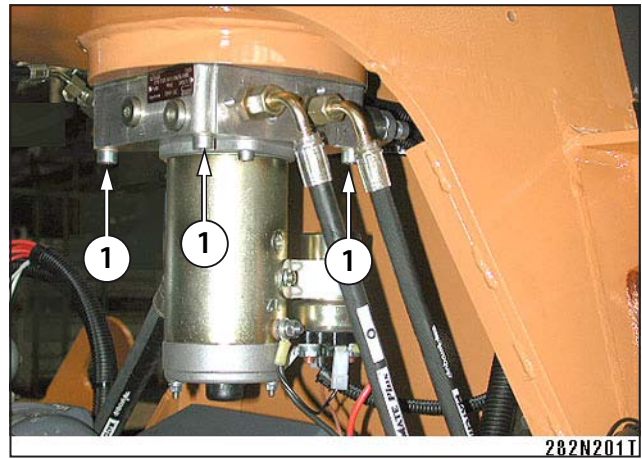

3.6.29. Exchanging the engine cooling liquid

**! NOTE !**

Exchange the coolant after operation of the machine or after warming the coolant (by running the engine) to 80 °C (176 °F).

- Open cooling system by removing pressure plug 1 on the equaliser reservoir.



Do not dismantle the pressure plug before the temperature of cooling liquid falls lower than to 50 °C (122 °F). Beware of gushing of the coolant and scalding when opening the pressure plug.

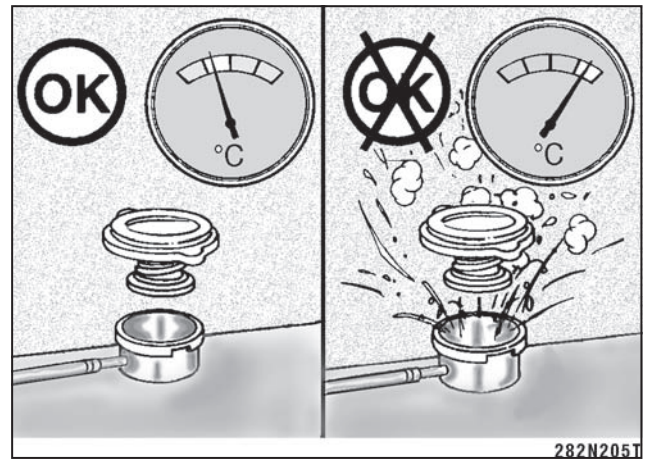
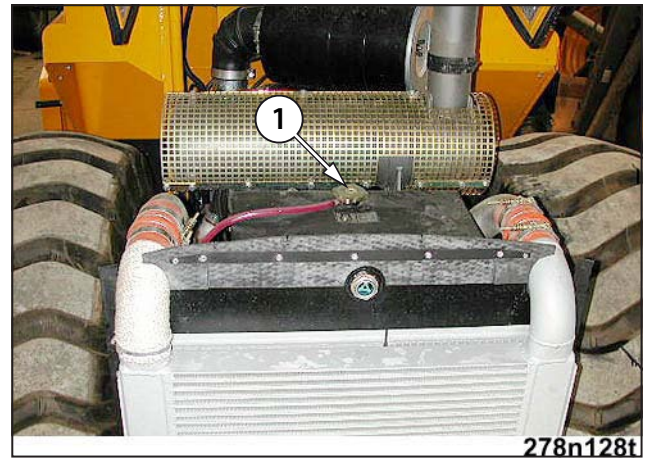

- Dismantle the drain plug.
- The quantity drained is approximately 32 l (8.5 US gal).



**NOTE**

Check cooling system for defective hoses and missing hose clips. Check the condition of the cooler - search for defects, leaks and cooling gills blocked with impurities.

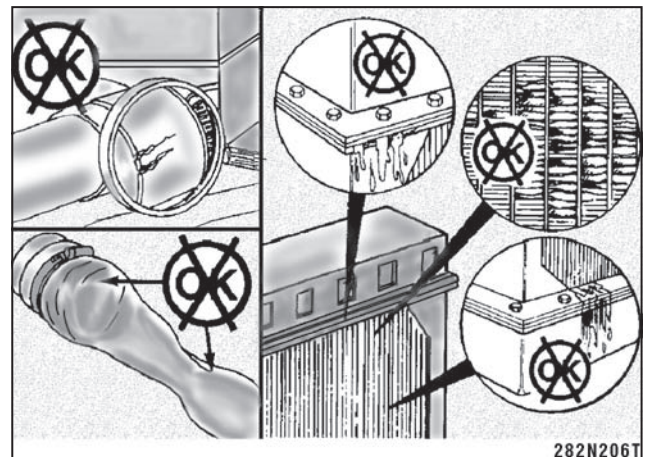

### 3.6. Individual Operations of Maintenance

- After closing the drain cock, fill cooling system with new cooling liquid with ratio of 50% of water + 50% of anti-freeze agent.

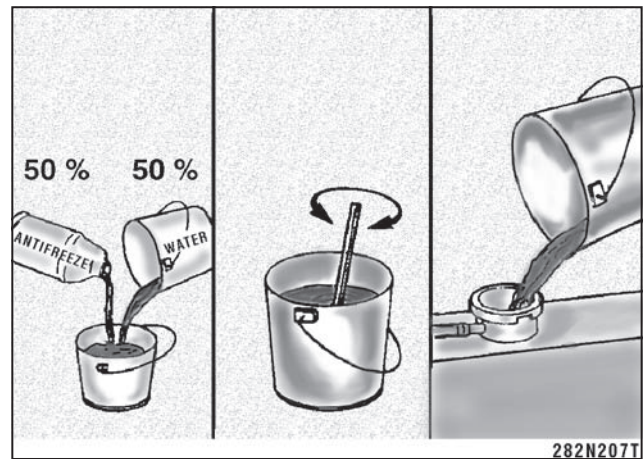

- Fill it up to the upper edge of the level indicator. After filling, wait for approx. 2-3 minutes until air goes off and the circuit is filled. The maximum filling rate is 19 l/min (5 US gal/min). Close the equaliser reservoir with the pressure plug.
- Start the engine and wait until the temperature reaches 80 °C (175 °F). Check during your waiting for any leakage of cooling liquid.
- Stop the engine.
- Check the level on the indicator. If the level is low, refill cooling liquid to maximum.

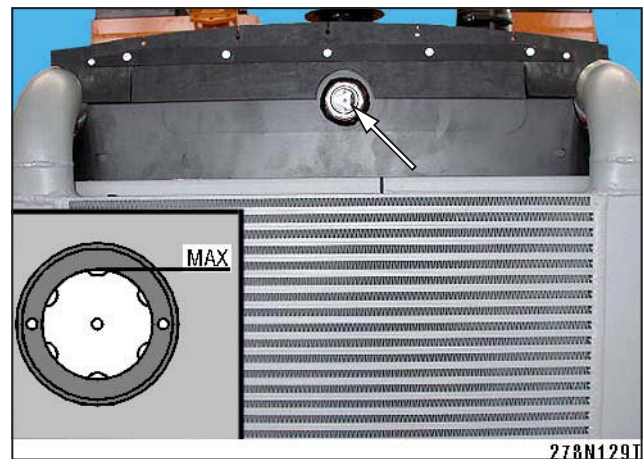

**Do not dismantle the pressure plug before the temperature of cooling liquid falls lower than to 50 °C (122 °F). Beware of gushing of the coolant and scalding when opening the pressure plug.**

**! NOTE !**

**Use cooling liquid according to chapter 3.2.3!**



**Follow the instructions of the manufacturer of anti-freeze fluid when changing coolant!**

**Protect your hands with gloves!**

**Use safety glasses or safety shield!**



**Collect used liquid and have it safely disposed according to valid regulations!**

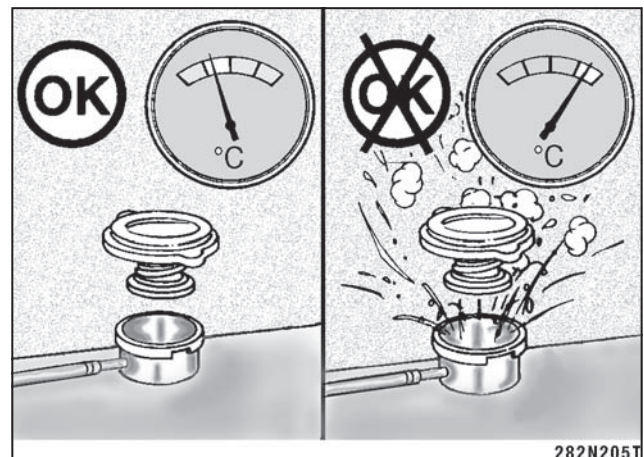

Maintenance - As Needed

3.6.30. Exchanging cleaner elements of air cleaner

NOTE

The air cleaner contains the main and safety elements.



If the indicator lamp lights up, replace the main element. The safety element should be replaced after three replacements of the main element. The manufacturer recommends that the elements should not be cleaned due to a decrease in the filtration capacity by up to 40 % and possible damaging of elements resulting from the cleaning.

- Lift the bonnet to the limit position. (See Operating instructions, chapter 2.7.6).
- Remove the lid.



- Carefully remove the main element.



- After remove the safety element.



### 3.6. Individual Operations of Maintenance

- Clean the inside of the cleaner and contact surface in order that the engine inlet pipe does not get blocked.



- Check connections and piping for any untightness and clogging of the engine inlet opening on the bonnet (e.g. by leaves).

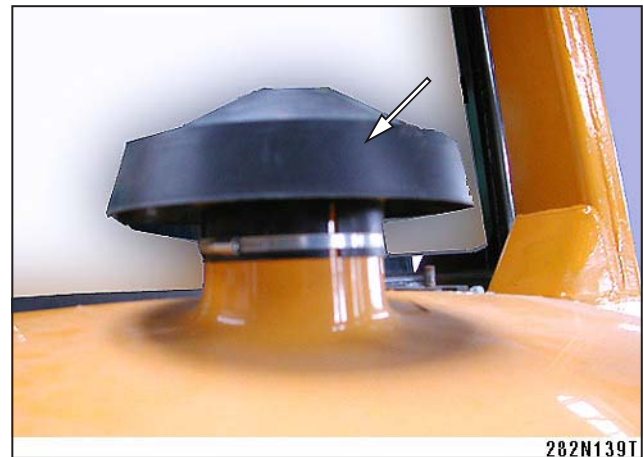

- Insert the safety element.
- Mount the new main element. Check whether the both cartridges fits correctly and whether are sealing.
- Remove the dust valve, clean it and mount it back.



**Do not clean the inside of the cleaner by pressure air; dust might get into the engine inlet piping.**

**Use original elements only.**

**When washing the machine, make sure water cannot pour into the air cleaner.**

**In case of absorbing water, exchange main element. Dry the cleaner body.**

**Replace defective vacuum valve immediately!**

**Do not operate the machine with damaged cleaner body or cover.**

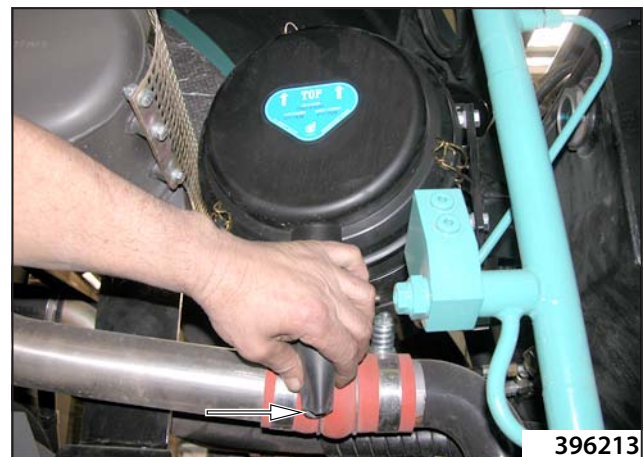

### 3.6.31. Cleaning of the water separator on the fuel filter

- Yellow indicator lamp signal.

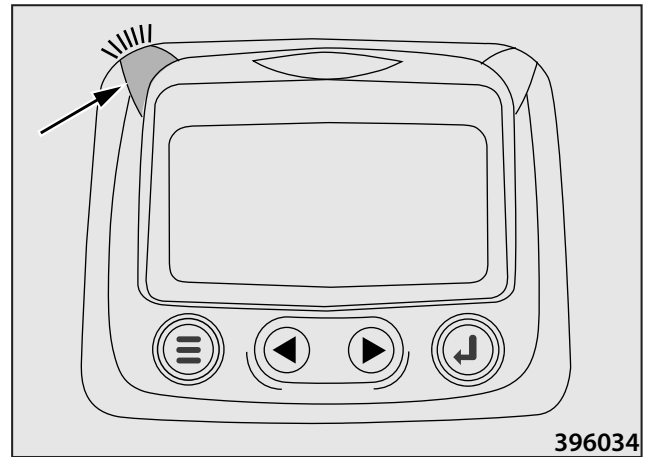

- The message. SPN 97 is displayed.

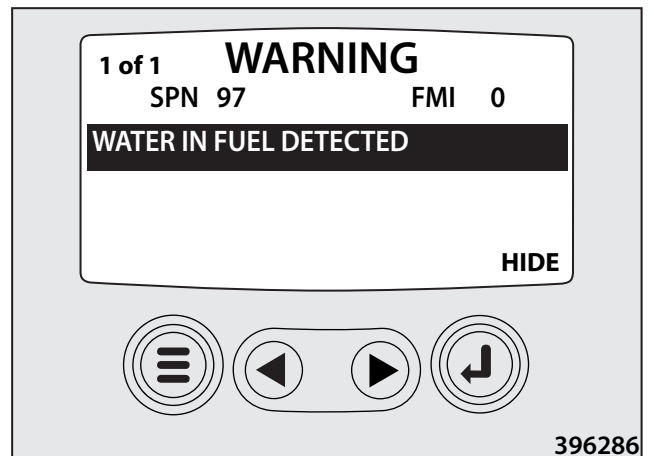

- Twist the separator valve , drain the water from filter.

 **Shut off the engine during separator draining!**

 **Drain water/fuel into a container and dispose of in accordance with local environmental regulations.**

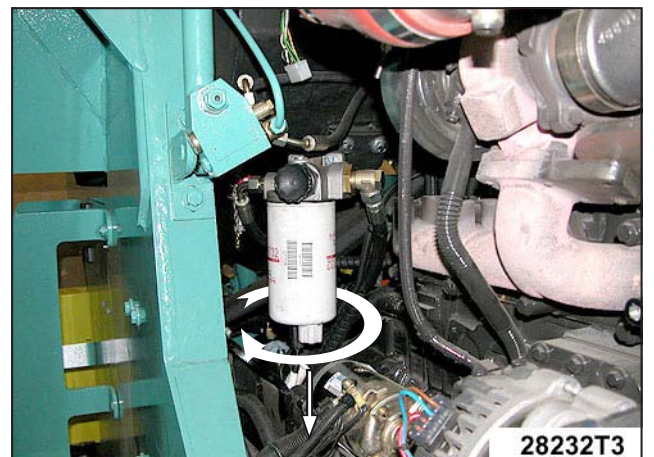

- If you drained over 60 cm<sup>3</sup> [0.63 quarts] of fuel refill the fuel into fuel filter. Open the bleed screw 1. Unscrew a transfer pump and operate until the fuel flowing is free of air.

 **Do not bleed the fuel with the hot engine flowing out fuel may cause a fire! No smoking et Work on fuel system!**

 **Drain fuel into a container and dispose of in accordance with local environmental regulations.**

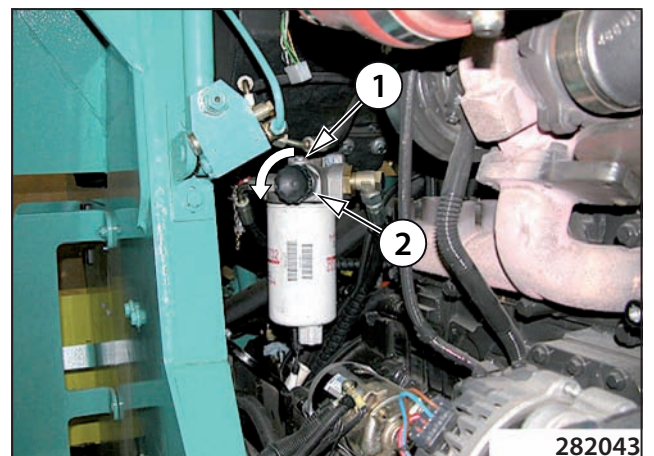

## 3.6. Individual Operations of Maintenance

### 3.6.32. Cleaning of coolers

- Due to variable working conditions it is not possible to determine any fixed interval of cleaning.
- In case of work in very dusty conditions clean the radiator daily. Clogged radiators will result in lower cooling capacity and increasing temperatures of engine cooling liquid and hydraulic oil.
- Clean it using pressure air or pressure water (steam). Cleaning direction is from the ventilator side.

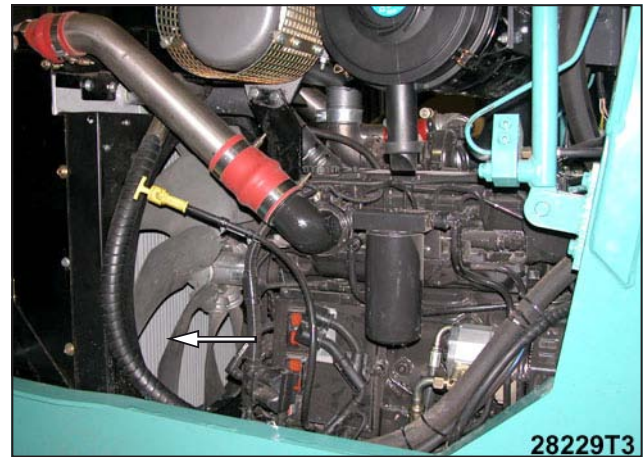

**Do not use cleaner with too high pressure so as not to damage radiator honeycombs.**

**In case of contamination of the radiator by oil products, use a cleaning agent and proceed according to the manufacturer's instructions! Find the cause of contamination!**



**Follow environmental standards and regulations when cleaning the machine!**

**Clean the machine in a site equipped with an intercepting system for cleaning agents so that the soil and water sources are not contaminated!**

**Do not use forbidden cleaning agents!**

### 3.6.33. Cleaning the air cleaner of cabin ventilation

- Dismantle the cover grill.



- Take out the cleaner with cleaning element.
- Carefully beat out the element and wash it in a detergent solution. If you damage the cleaning element or you are not able to clean it properly, replace it with a new one.

**! NOTE !**  
**Clean it once in a month. In case you work in very dusty conditions, make the interval shorter.**

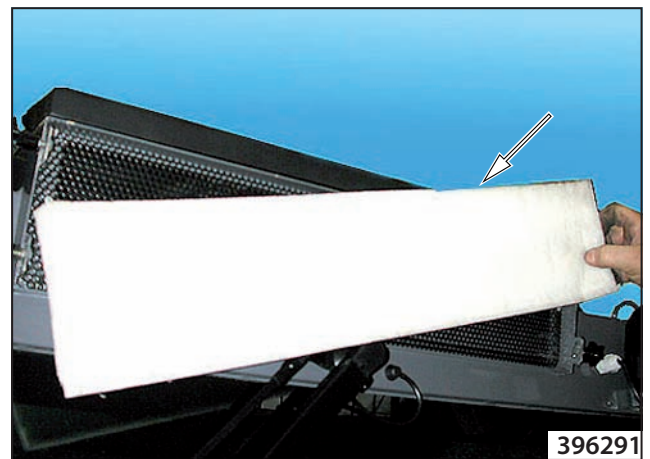

- Dismantle the cover grill.
- Take out the cleaner with cleaning element.
- Carefully beat out the element and wash it in a detergent solution. If you damage the cleaning element or you are not able to clean it properly, replace it with a new one.

**! NOTE !**  
**Clean it once in a month. In case you work in very dusty conditions, make the interval shorter.**

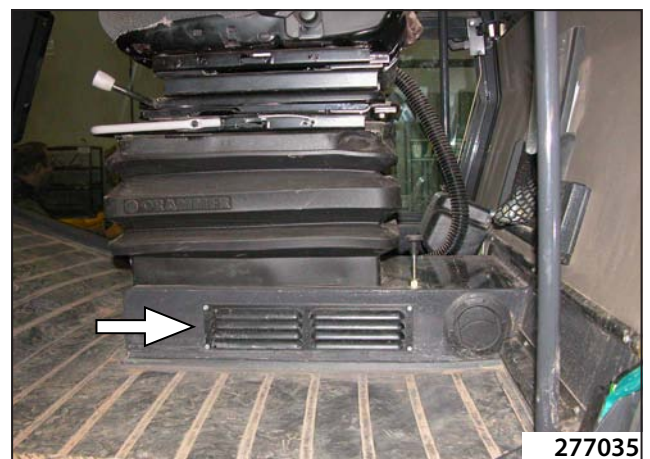

## 3.6. Individual Operations of Maintenance

---

### 3.6.34. Cleaning the machine

- Clean the machine from major impurities after finishing your work.
- Perform overall cleaning regularly at least once in a week. When working in cohesive soils, cement and lime stabilisation's, the overall cleaning must be performed daily.



**Blind all openings into which the cleaning agent might penetrate (e.g. engine inlet opening) prior to pressure water washing. Remove these blinders after washing the machine.**

**Do not expose electric parts or insulation material to direct water or steam flow. Always cover such materials (inside of the alternator etc.).**

**Disconnect batteries using the isolating master switch.**

**Work with stopped engine.**

**Do not use aggressive and highly inflammable cleaning agents (e.g. petrol or highly inflammable materials).**



**Follow environmental standards and regulations when cleaning the machine!**

**Clean the machine in a site equipped with an intercepting system for cleaning agents so that the soil and water sources are not contaminated!**

**Do not use forbidden cleaning agents!**

### 3.6.35. Adjusting scrapers

#### Scrapers for the smooth drum

- Loosen bolts 1, see fig., and move holders 2 towards the drum to the distance of 15 mm (0.6 in) between the scraper and the drum.

**! NOTE !**

If you can not move scrapers any more within the range of oval openings of the holders 2 due to the wear of the scrapers, dismantle the scraper 3 and move it closer to the drum by one hole.

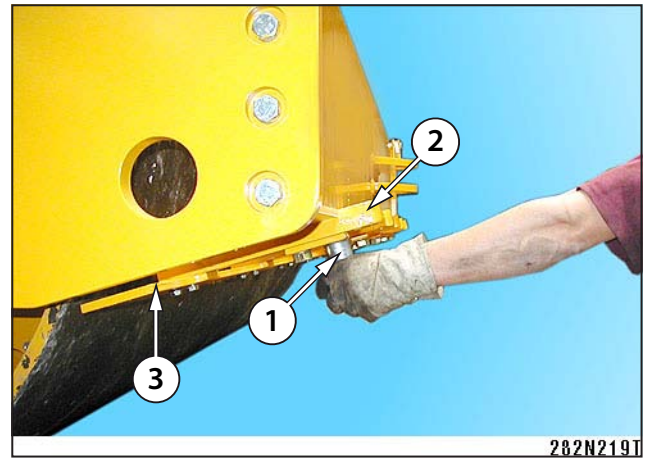

#### Scrapers for the taper foot drum

- Loosen bolts 1 and move individual scrapers 2 towards the drum to the distance of 25 mm (1 in).



Rear scrapers of the taper foot drum are longer. When replacing worn scrapers, replace the front scrapers with rear ones and the rear scrapers with new ones. If you set too short distance between the scraper and drum, they may get into contact when cornering with the machine.



### 3.6.36. Vibrator cooling mixture

- The drum water filling is a filling for the whole service life and it is not necessary to exchange it. The lower plug is used for draining the water, the upper plug is for filling up and checking the water level. When draining the water, make sure that the drum is in an inclined position for draining the liquid. After the drum has been filled up, drive the machine so that the plugs are at an opposite position (upward). Fill the liquid up to the level according to chapter 3.2.8.



Do not operate the machine without the drum being filled with water!

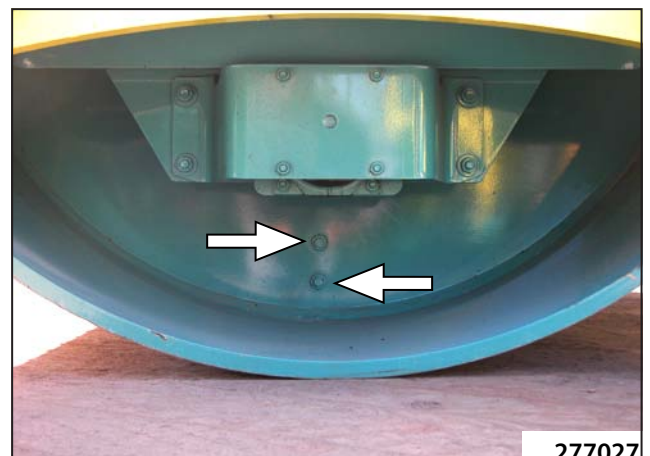

## 3.6. Individual Operations of Maintenance

### 3.6.37. Check of the screw connection tightening

- Check regularly that no bolted connections have been slackened. Use torque spanners to tighten.

Thread	Torque				Thread	Torque			
	For 8,8 Bolts (8G)		For 10,9 Bolts (10K)			For 8,8 Bolts (8G)		For 10,9 Bolts (10K)	
	Nm	lb ft	Nm	lb ft		Nm	lb ft	Nm	lb ft
M6	10	7,4	14	10,3	M18x1,5	220	162,2	312	230,1
M8	24	25,0	34	25,0	M20	390	287,6	550	405,6
M8x1	19	14,0	27	19,9	M20x1,5	312	230,1	440	324,5
M10	48	35,4	67	49,4	M22	530	390,9	745	549,4
M10x1,25	38	28,0	54	39,8	M22x1,5	425	313,4	590	435,1
M12	83	61,2	117	86,2	M24	675	497,8	950	700,6
M12x1,25	66	48,7	94	69,3	M24x2	540	398,2	760	560,5
M14	132	97,3	185	136,4	M27	995	733,8	1400	1032,5
M14x1,5	106	78,2	148	109,1	M27x2	795	586,3	1120	826,0
M16	200	147,5	285	210,2	M30	1350	995,7	1900	1401,3
M16x1,5	160	118,0	228	168,1	M30x2	1080	796,5	1520	1121,0
M18	275	202,8	390	287,6					

Values given in the Table are the torques at dry tread (at coefficient of friction = 0,14). Such values do NOT apply to a greased thread.

**Table of torques used for cap nuts with sealing "O" ring - hoses**

Spanner Size	Thread	Pipe	Torques for cap nuts incl. "O" ring - hoses					
			Nm			lb ft		
			Nominal	Min	Max	Nominal	Min	Max
14	12x1,5	6	20	15	25	15	11	18
17	14x1,5	8	38	30	45	28	22	33
19	16x1,5	8	45	38	52	33	28	38
		10						
22	18x1,5	10	51	43	58	38	32	43
		12						
24	20x1,5	12	58	50	65	43	37	48
27	22x1,5	14	74	60	88	55	44	65
		15						
30	24x1,5	16	74	60	88	55	44	65
32	26x1,5	18	105	85	125	77	63	92
36	30x2	20	135	115	155	100	85	114
		22						
41	36x2	25	166	140	192	122	103	142
46		28						
50	42x2	30	240	210	270	177	155	199
50	52x2	35	290	255	325	214	188	240
		38						
		42						

**Chart for torques of necks with sealing edge or with flat gasket**

G -M	Neck Torques	
	Nm	lb ft
G 1/8	25	18
G 1/4	40	30
G 3/8	95	70
G 1/2	130	96
G 3/4	250	184
G 1	400	295
G 1 1/4	600	443
G 1 1/2	800	590
10 x 1	25	18
12 x 1,5	30	22
14 x 1,5	50	37
16 x 1,5	60	44
18 x 1,5	60	44
20 x 1,5	140	103
22 x 1,5	140	103
26 x 1,5	220	162
27 x 1,5	250	184
33 x 1,5	400	295
42 x 1,5	600	443
48 x 1,5	800	590

**Chart for torques of plugs with flat gasket**

G -M	Plug Torques	
	Nm	lb ft
G 1/8	15	11
G 1/4	33	24
G 3/8	70	52
G 1/2	90	66
G 3/4	150	111
G 1	220	162
G 1 1/4	600	443
G 1 1/2	800	590
10 x 1	13	10
12 x 1,5	30	22
14 x 1,5	40	30
16 x 1,5	60	44
18 x 1,5	70	52
20 x 1,5	90	66
22 x 1,5	100	74
26 x 1,5	120	89
27 x 1,5	150	111
33 x 1,5	250	184
42 x 1,5	400	295
48 x 1,5	500	369

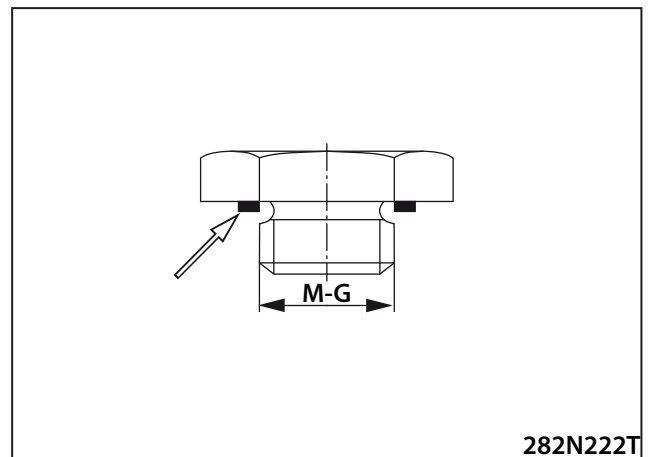
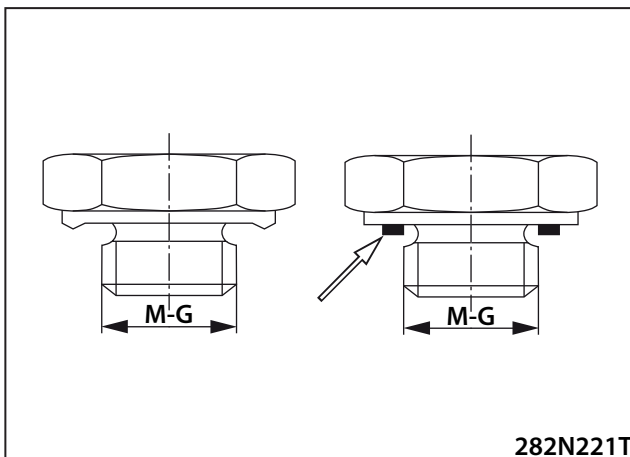





Usually, defects are caused by incorrect operation of the machine. Therefore, in case of any troubles read again properly through the instructions given in the operation and maintenance manual for the machine and engine. If you cannot identify the cause, contact a service department of an authorised dealer or the manufacturer.



Troubleshooting in hydraulic and electric systems requires knowledge of these systems; therefore a service department of an authorised dealer or the manufacturer should be called to solve these problems.

## 3.8. Annexes

### Wiring diagram

**Seat switch; Engine Tier 3; RTM MODULE; MURPHY Power view gauge (the schematic reflects machine version that includes all controlling elements and accessories)**

#### Legend:

A1 - Clicker for direction-indicator lights (optional)	M1 - Engine starter	S29 - Cab fan selector switch
A2 - Electronics to secure travel	M2 - Motor for cab lifting pump	S30 - Front wiper switch
A3 - Travel actuator	M3 - Cab ventilation fan	S31 - Rear wiper switch
A4 - Multifunctional display Murphy PV - 101	M4 - Front wiper	S32 - Washer pushbutton
B2 - Hydraulic oil thermometer sensor	M5 - Rear wiper	S33 - Heater fan selector switch
B3 - Float (displacer) in fuel tank	M6 - Windscreen washer	S35 - Parking brake switch
E1 - Hydraulics thermometer lighting	M7 - Rear glass washer	S36 - Switch to reduce drum slip
E2,3 - Front fender lights (optional)	M8 - Heater fan	S37 - Engine idling switch
E4,5 - Rear lamps (optional)	P2 - Hydraulic oil thermometer	S39 - Double pushbutton to adjust idle rpm
E6,7 - Front headlights	Q1 - Battery disconnecter	S40 - RTM module switch (ATC)
E8,9 - Rear headlights	R1,2,5,6 - Resistors	V3 - Interlocking LED (only with Machines having cab lifting alarm)
E10,11 - LH direction-indicator lights (optional)	R3 - Engine preheating	V4 -7 - Interlocking LEDs
E12,13 - RH direction-indicator lights (optional)	R4 - Engine revolution control potentiometer	X2-24 - Interface connectors
E14 - Cab lighting	S1 - Cab lifting pushbutton	X27 - Socket for hazard beacon
E15 - Hazard beacon (optional)	S2 - Bonnet lifting pushbutton	X28-33 - Interface connectors
F1-12 - Drop-out fuses	S3 - Ignition box	X34 - Socket for engine diagnostics
G1,2 - Batteries	S4 - Front headlight switch	X35-40 - J1939 Connector
G3 - Alternator	S5 - Rear headlight switch	X41,42 - Interface connectors
H1 - Pilot lamp for direction-indicator lights (optional)	S6 - Warning light switch (optional)	Y1 - Solenoid valve for cab lifting
H2 - Horn	S7 - Direction-indicator light change-over switch (optional)	Y2 - Solenoid valve for cab lowering
H3 - Backing horn (optional)	S8 - Hazard beacon switch (optional)	Y3 - Solenoid valve for bonnet lifting
H4 - Pilot lamp for hydraulic oil level	S9 - Horn pushbutton	Y4 - Solenoid valve for bonnet lowering
H5 - Pilot lamp for neutral	S11 - Emergency brake pushbutton	Y6 - Solenoid valve for brake
H6 - Pilot lamp for brake	S12 - Backing horn switch (in travel actuator)	Y7 - Solenoid valve for fast travel - left wheel
H7 - Pilot lamp for vibration preset	S13 - Neutral switch (in travel actuator)	Y8 - Solenoid valve for fast travel - drum
H8 - Pilot lamp for differential interlock	S14 - Float (displacer) inside hydraulic oil tank	Y9 - Solenoid valve vibrations 1
H10 - Pilot lamp for battery recharging	S16 - Fast travel switch	Y10 - Solenoid valve for vibrations 2
H11 - Pilot lamp for air filter clogged	S17 - Selector switch for operating speed preset	Y11 - Solenoid valve to disengage RTM differential interlock
H12 - Pilot lamp for hydraulic oil filter clogged	S18 - Vibration selector switch	Y13 - Servo valve for travel pump
H17 - Pilot lamp for glowing (WTS)	S19 - Vibration switch (in travel actuator)	Y14 - Solenoid valve for fast travel - right wheel
K1 - Starting contactor	S21 - Brake pressure switch	
K2-9 - Auxiliary relays	S22 - Seat switch	
K10 - Glowing contactor	S27 - Vacuum switch for air filter clogged	
K11 - Auxiliary relay	S28 - Vacuum switch for hydraulic oil filter clogged	

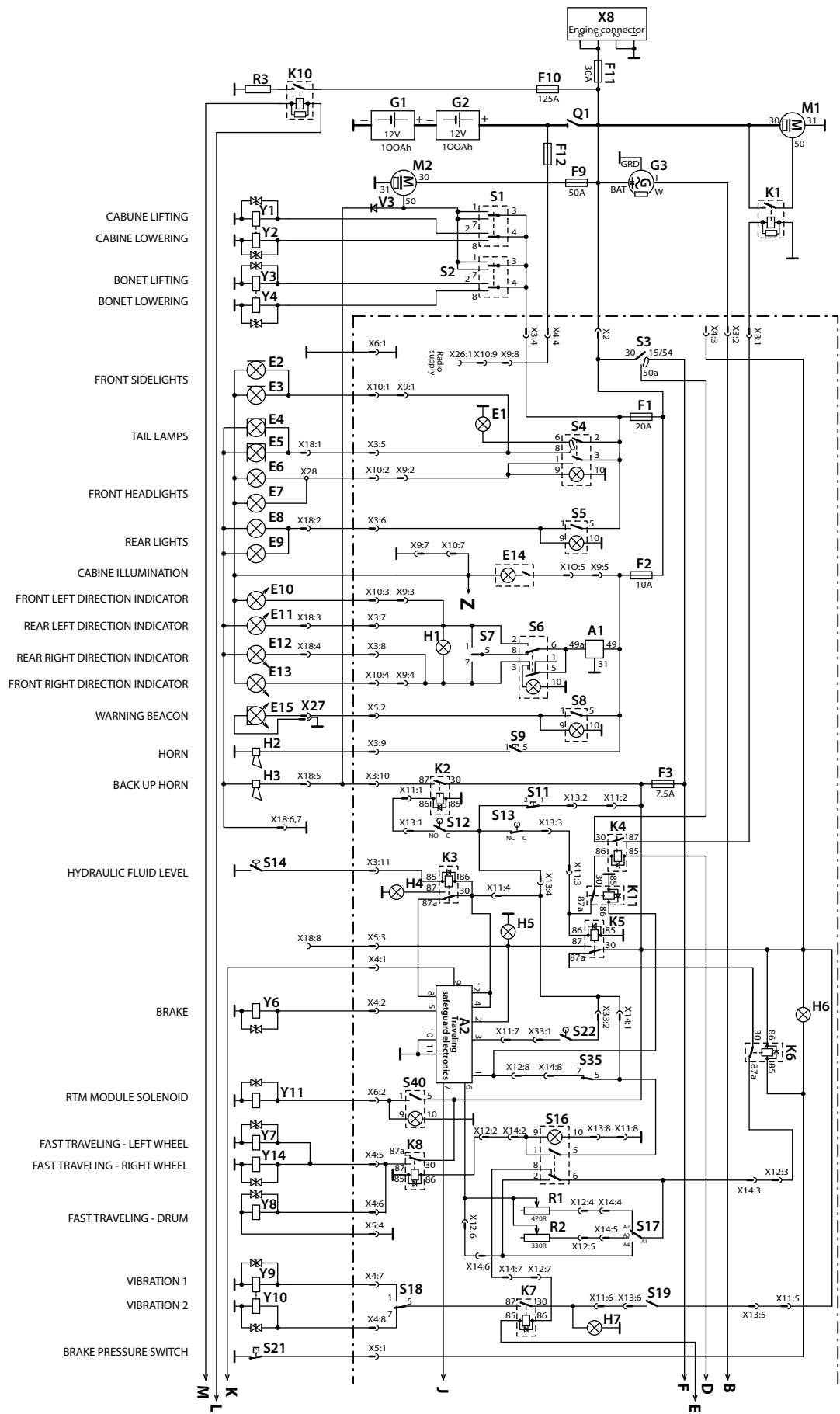

211466\_1en

## 3.8. Annexes

---

### Wiring diagram

**Seat switch; Engine Tier 3; RTM MODULE; MURPHY Power view gauge (the schematic reflects machine version that includes all controlling elements and accessories)**

**Legend:**

A1 - Clicker for direction-indicator lights (optional)	M1 - Engine starter	S29 - Cab fan selector switch
A2 - Electronics to secure travel	M2 - Motor for cab lifting pump	S30 - Front wiper switch
A3 - Travel actuator	M3 - Cab ventilation fan	S31 - Rear wiper switch
A4 - Multifunctional display Murphy PV - 101	M4 - Front wiper	S32 - Washer pushbutton
B2 - Hydraulic oil thermometer sensor	M5 - Rear wiper	S33 - Heater fan selector switch
B3 - Float (displacer) in fuel tank	M6 - Windscreen washer	S35 - Parking brake switch
E1 - Hydraulics thermometer lighting	M7 - Rear glass washer	S36 - Switch to reduce drum slip
E2,3 - Front fender lights (optional)	M8 - Heater fan	S37 - Engine idling switch
E4,5 - Rear lamps (optional)	P2 - Hydraulic oil thermometer	S39 - Double pushbutton to adjust idle rpm
E6,7 - Front headlights	Q1 - Battery disconnecter	S40 - RTM module switch (ATC)
E8,9 - Rear headlights	R1,2,5,6 - Resistors	V3 - Interlocking LED (only with Machines having cab lifting alarm)
E10,11 - LH direction-indicator lights (optional)	R3 - Engine preheating	V4 -7 - Interlocking LEDs
E12,13 - RH direction-indicator lights (optional)	R4 - Engine revolution control potentiometer	X2-24 - Interface connectors
E14 - Cab lighting	S1 - Cab lifting pushbutton	X27 - Socket for hazard beacon
E15 - Hazard beacon (optional)	S2 - Bonnet lifting pushbutton	X28-33 - Interface connectors
F1-12 - Drop-out fuses	S3 - Ignition box	X34 - Socket for engine diagnostics
G1,2 - Batteries	S4 - Front headlight switch	X35-40 - J1939 Connector
G3 - Alternator	S5 - Rear headlight switch	X41,42 - Interface connectors
H1 - Pilot lamp for direction-indicator lights (optional)	S6 - Warning light switch (optional)	Y1 - Solenoid valve for cab lifting
H2 - Horn	S7 - Direction-indicator light change-over switch (optional)	Y2 - Solenoid valve for cab lowering
H3 - Backing horn (optional)	S8 - Hazard beacon switch (optional)	Y3 - Solenoid valve for bonnet lifting
H4 - Pilot lamp for hydraulic oil level	S9 - Horn pushbutton	Y4 - Solenoid valve for bonnet lowering
H5 - Pilot lamp for neutral	S11 - Emergency brake pushbutton	Y6 - Solenoid valve for brake
H6 - Pilot lamp for brake	S12 - Backing horn switch (in travel actuator)	Y7 - Solenoid valve for fast travel - left wheel
H7 - Pilot lamp for vibration preset	S13 - Neutral switch (in travel actuator)	Y8 - Solenoid valve for fast travel - drum
H8 - Pilot lamp for differential interlock	S14 - Float (displacer) inside hydraulic oil tank	Y9 - Solenoid valve vibrations 1
H10 - Pilot lamp for battery recharging	S16 - Fast travel switch	Y10 - Solenoid valve for vibrations 2
H11 - Pilot lamp for air filter clogged	S17 - Selector switch for operating speed preset	Y11 - Solenoid valve to disengage RTM differential interlock
H12 - Pilot lamp for hydraulic oil filter clogged	S18 - Vibration selector switch	Y13 - Servo valve for travel pump
H17 - Pilot lamp for glowing (WTS)	S19 - Vibration switch (in travel actuator)	Y14 - Solenoid valve for fast travel - right wheel
K1 - Starting contactor	S21 - Brake pressure switch	
K2-9 - Auxiliary relays	S22 - Seat switch	
K10 - Glowing contactor	S27 - Vacuum switch for air filter clogged	
K11 - Auxiliary relay	S28 - Vacuum switch for hydraulic oil filter clogged	

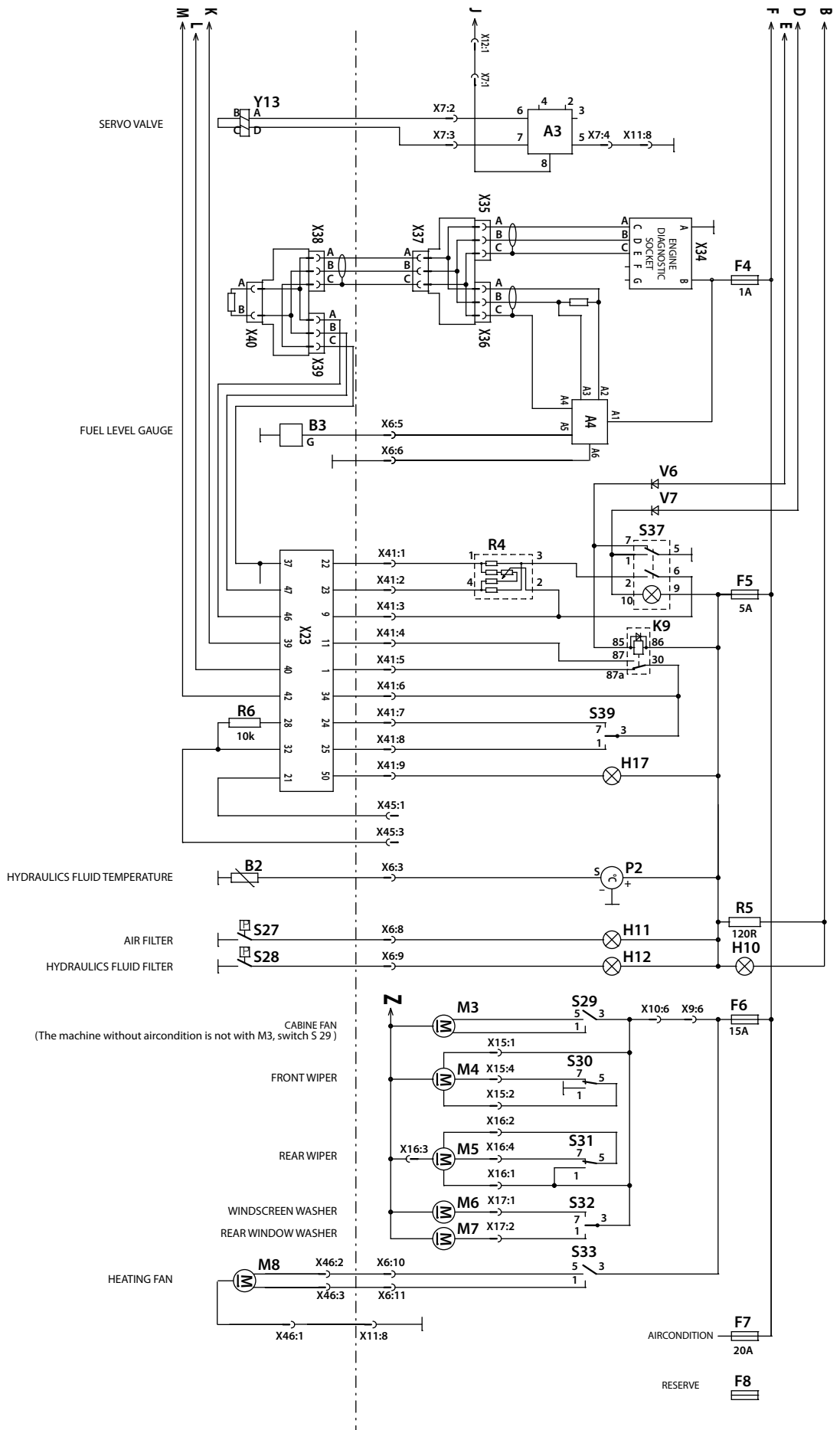

211466\_2en

## 3.8. Annexes

### Wiring diagram

**Seat switch; Engine Tier 3; RTM MODULE; MURPHY Power view gauge (the schematic reflects machine version that includes all controlling elements and accessories)**

#### Legend:

A1 - Clicker for direction-indicator lights (optional)	M1 - Engine starter	S29 - Cab fan selector switch
A2 - Electronics to secure travel	M2 - Motor for cab lifting pump	S30 - Front wiper switch
A3 - Travel actuator	M3 - Cab ventilation fan	S31 - Rear wiper switch
A4 - Multifunctional display Murphy PV - 101	M4 - Front wiper	S32 - Washer pushbutton
B2 - Hydraulic oil thermometer sensor	M5 - Rear wiper	S33 - Heater fan selector switch
B3 - Float (displacer) in fuel tank	M6 - Windscreen washer	S35 - Parking brake switch
E1 - Hydraulics thermometer lighting	M7 - Rear glass washer	S36 - Switch to reduce drum slip
E2,3 - Front fender lights (optional)	M8 - Heater fan	S37 - Engine idling switch
E4,5 - Rear lamps (optional)	P2 - Hydraulic oil thermometer	S39 - Double pushbutton to adjust idle rpm
E6,7 - Front headlights	Q1 - Battery disconnecter	S40 - RTM module switch (ATC)
E8,9 - Rear headlights	R1,2,5,6 - Resistors	V3 - Interlocking LED (only with Machines having cab lifting alarm)
E10,11 - LH direction-indicator lights (optional)	R3 - Engine preheating	V4 - 7 - Interlocking LEDs
E12,13 - RH direction-indicator lights (optional)	R4 - Engine revolution control potentiometer	X2-24 - Interface connectors
E14 - Cab lighting	S1 - Cab lifting pushbutton	X27 - Socket for hazard beacon
E15 - Hazard beacon (optional)	S2 - Bonnet lifting pushbutton	X28-33 - Interface connectors
F1-12 - Drop-out fuses	S3 - Ignition box	X34 - Socket for engine diagnostics
G1,2 - Batteries	S4 - Front headlight switch	X35-40 - J1939 Connector
G3 - Alternator	S5 - Rear headlight switch	X41,42 - Interface connectors
H1 - Pilot lamp for direction-indicator lights (optional)	S6 - Warning light switch (optional)	Y1 - Solenoid valve for cab lifting
H2 - Horn	S7 - Direction-indicator light change-over switch (optional)	Y2 - Solenoid valve for cab lowering
H3 - Backing horn (optional)	S8 - Hazard beacon switch (optional)	Y3 - Solenoid valve for bonnet lifting
H4 - Pilot lamp for hydraulic oil level	S9 - Horn pushbutton	Y4 - Solenoid valve for bonnet lowering
H5 - Pilot lamp for neutral	S11 - Emergency brake pushbutton	Y6 - Solenoid valve for brake
H6 - Pilot lamp for brake	S12 - Backing horn switch (in travel actuator)	Y7 - Solenoid valve for fast travel - left wheel
H7 - Pilot lamp for vibration preset	S13 - Neutral switch (in travel actuator)	Y8 - Solenoid valve for fast travel - drum
H8 - Pilot lamp for differential interlock	S14 - Float (displacer) inside hydraulic oil tank	Y9 - Solenoid valve vibrations 1
H10 - Pilot lamp for battery recharging	S16 - Fast travel switch	Y10 - Solenoid valve for vibrations 2
H11 - Pilot lamp for air filter clogged	S17 - Selector switch for operating speed preset	Y11 - Solenoid valve to disengage RTM differential interlock
H12 - Pilot lamp for hydraulic oil filter clogged	S18 - Vibration selector switch	Y13 - Servo valve for travel pump
H17 - Pilot lamp for glowing (WTS)	S19 - Vibration switch (in travel actuator)	Y14 - Solenoid valve for fast travel - right wheel
K1 - Starting contactor	S21 - Brake pressure switch	
K2-9 - Auxiliary relays	S22 - Seat switch	
K10 - Glowing contactor	S27 - Vacuum switch for air filter clogged	
K11 - Auxiliary relay	S28 - Vacuum switch for hydraulic oil filter clogged	

Connection of electromagnetic valves Y7, Y8 and Y14 for machines with wheel differential lock.

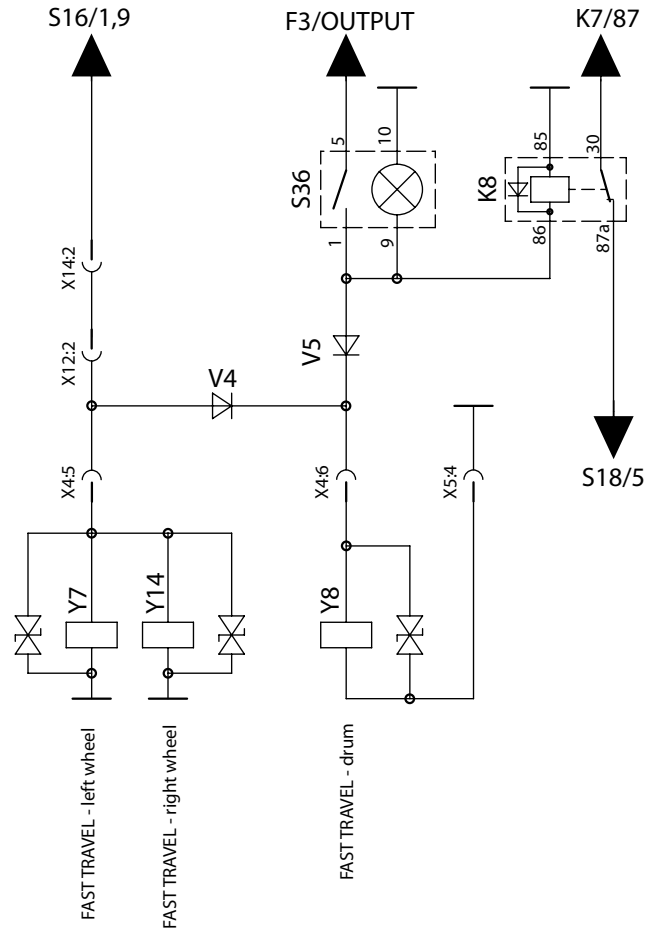

211466\_3en

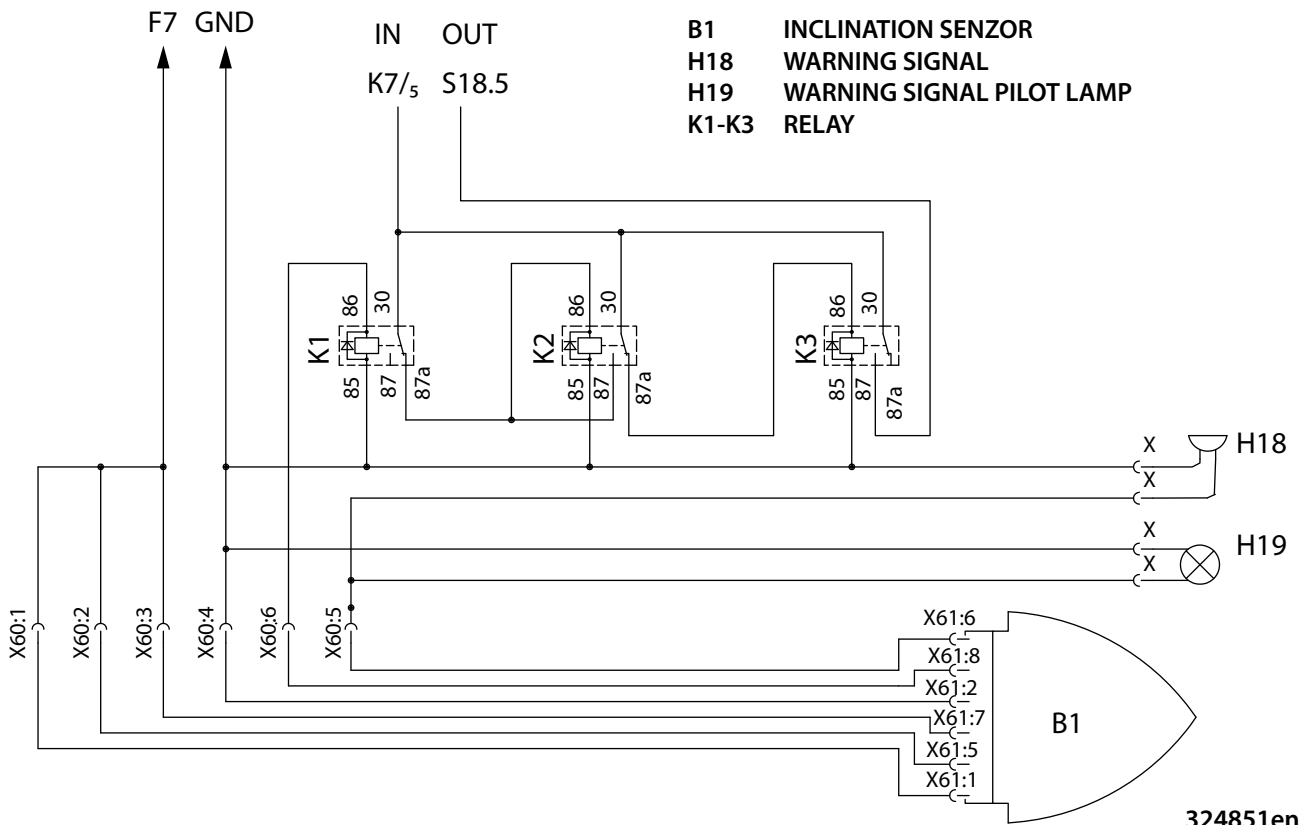

324851en

## 3.8. Annexes

---

### Hydraulic system diagram - INTER - Wheel differential lock

**Diagram:**

- 1 - Travel pump
- 2 - Vibration pump
- 3 - Drum travel hydromotor
- 4 - Vibration hydromotor
- 5 - Left wheel travel hydromotor
- 6 - Right wheel travel hydromotor
- 7 - Divider block
- 8 - Steering pump
- 9 - Power-assisted steering
- 10 - Brake block
- 11 - Hydraulic cylinder - steering
- 12 - Flushing Block
- 13 - Pressure switch
- 14 - Suction strainer
- 15 - Filter
- 16 - Filler neck
- 17 - Level indicator
- 18 - Combined cooler
- 19 - One-way valve (check valve)
- 20 - Thermo-regulator
- 21 - Quick-coupler for measuring
- 22 - Quick-coupler for filling
- 23 - Quick-coupler
- 24 - Quick-coupler
- 25 - Thermometer sensor
- 26 - Lifting unit
- 27 - Manual pump
- 28 - Lifting block
- 29 - Hydraulic lock
- 30 - Hydromotor - cab lifting
- 31 - Hydromotor - bonnet lifting

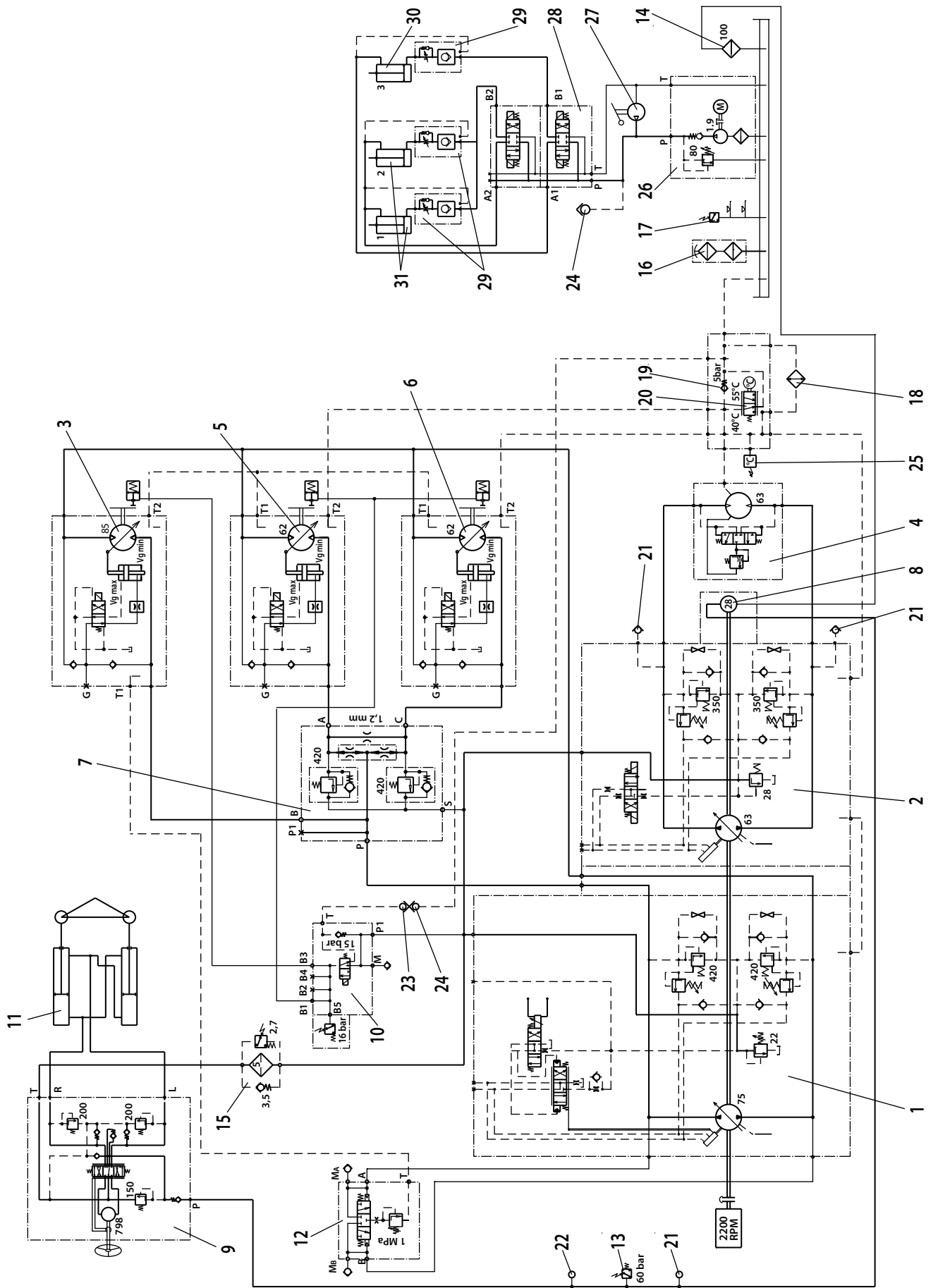

211497

## 3.8. Annexes

---

### Hydraulic system diagram - Interaxle differential lock ATC

**Diagram:**

- 1 - Travel pump
- 2 - Vibration pump
- 3 - Drum travel hydromotor
- 4 - Vibration hydromotor
- 5 - Left wheel travel hydromotor
- 6 - Right wheel travel hydromotor
- 7 - RTM Module
- 8 - Steering pump
- 9 - Power-assisted steering
- 10 - Brake block
- 11 - Hydraulic cylinder - steering
- 12 - RTM control block
- 13 - Pressure switch
- 14 - Suction strainer
- 15 - Filter
- 16 - Filler neck
- 17 - Level indicator
- 18 - Cooler combined-type
- 19 - One-way valve
- 20 - Thermoregulator
- 21 - Quick-coupler for measuring
- 22 - Quick-coupler for filling
- 23 - Quick-coupler
- 24 - Quick-coupler
- 25 - Thermometer sensor
- 26 - Lifting unit
- 27 - Manual pump
- 28 - Lifting block
- 29 - Hydraulic lock
- 30 - Hydromotor - cab lifting
- 31 - Hydromotor - bonnet lifting

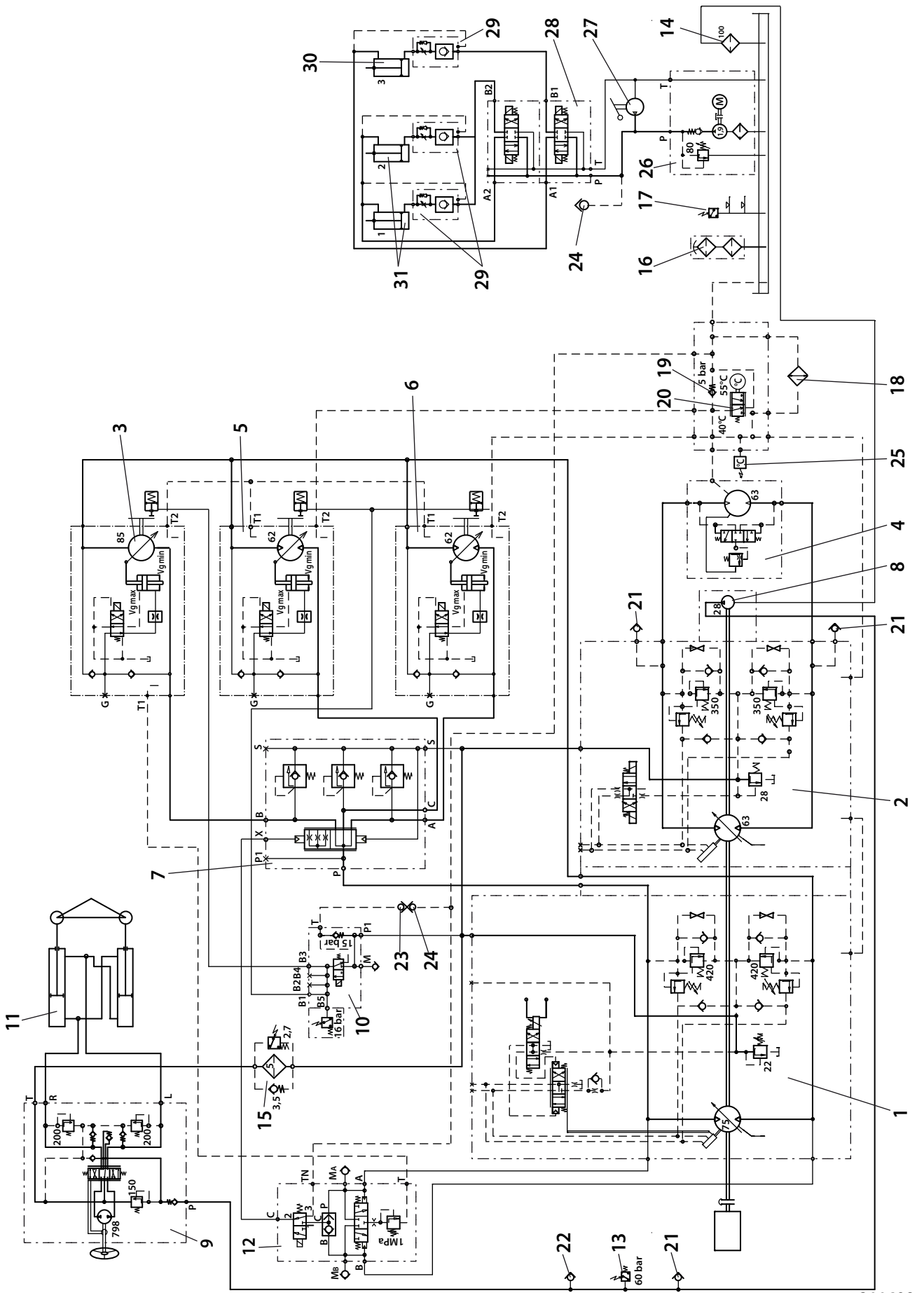

211498



<b>Notes</b>





Ammann Unternehmungen  
Eisenbahnstrasse 25  
CH-4901 Langenthal  
Phone +41 62 916 61 61

[www.ammann-group.com](http://www.ammann-group.com)